

Hypertherm[®]

ArcWriter[®]

Contactors Replacement

Kit # (128774)



Field Service Bulletin
(P/N 804450)

Revision 0 – July, 2002

Hypertherm, Inc.
Hanover, NH USA
www.hypertherm.com

© Copyright 2002 Hypertherm, Inc.
All Rights Reserved

Hypertherm and ArcWriter are trademarks of Hypertherm, Inc.
and may be registered in the United States and/or other countries

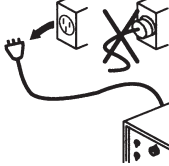
		<p>WARNING ELECTRIC SHOCK CAN KILL</p>
	<p>Disconnect electrical power before performing any maintenance. All work requiring removal of the cover must be performed by a qualified technician. See <i>Section 1</i> of the Operator Manual for more safety precautions.</p>	

Introduction

Purpose

Replacement of the contactor. The old contactor has been obsoleted.

Kit # 128774: Contents

Part Number	Description	Qty
003212	Contactor: 3P with AC coil	1
075063	Screws: 6-32 x 1/2 inch	2
104000	Center Rail	1

ArcWriter CONTACTOR REPLACEMENT

- ① Remove cover from power supply.

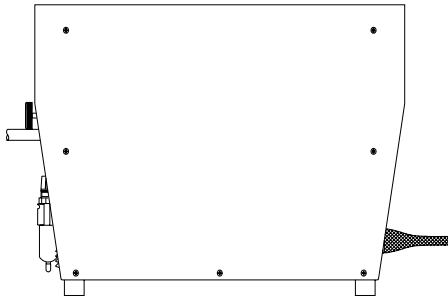

- ② Locate contactor and disconnect all wires.

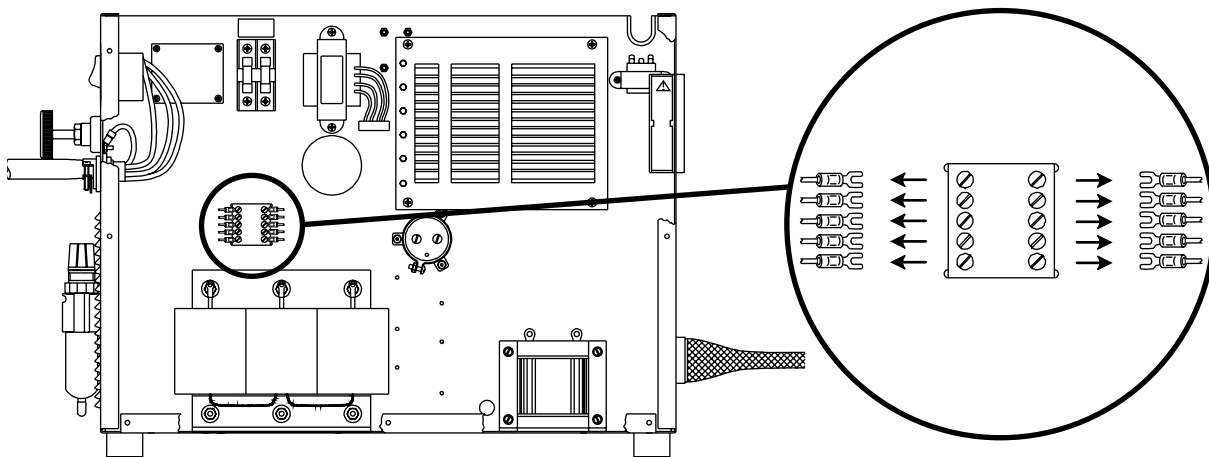

- ③ Remove screws (4) and discard old contactor and screws.

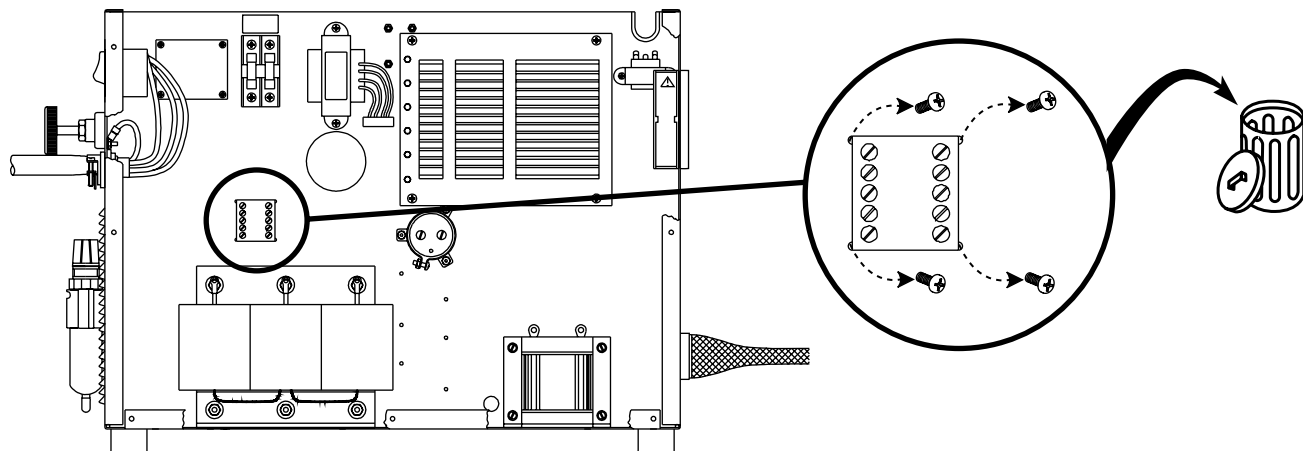

- ④ Use the 2 existing holes shown below and the 2 screws (075063) provided in this kit to install the DIN rail (104000).

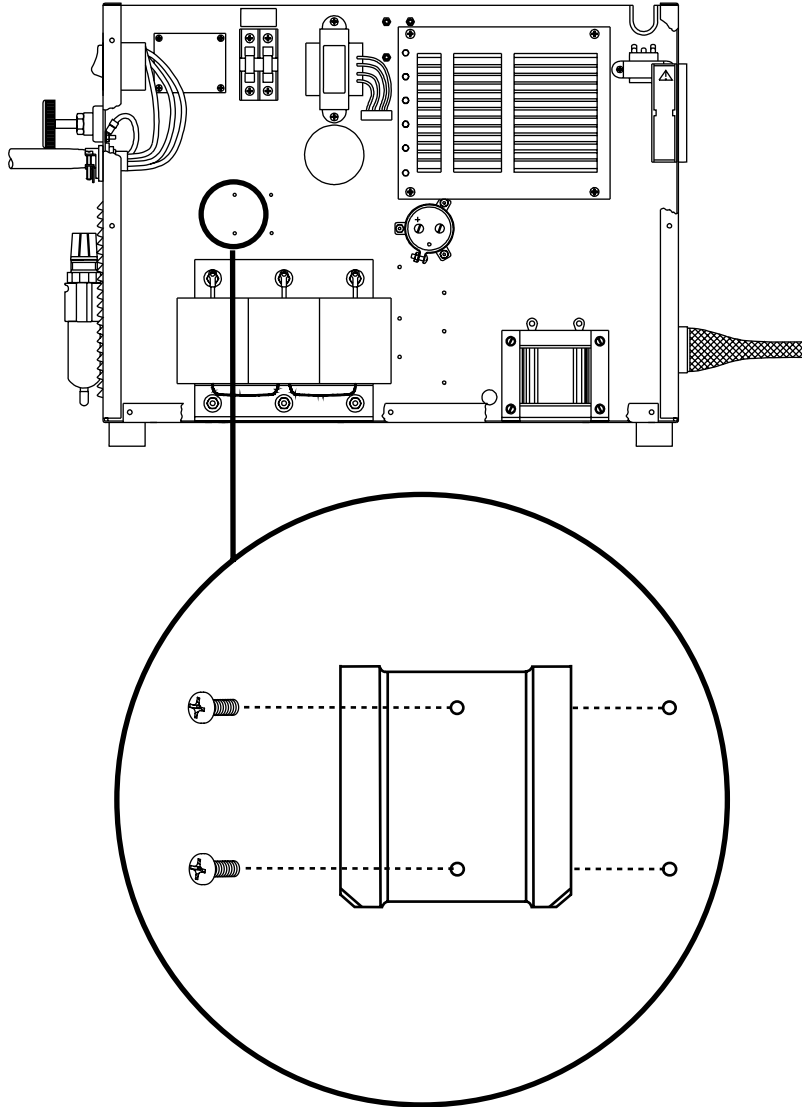

ArcWriter CONTACTOR REPLACEMENT

⑤ Slide new contactor on DIN rail. See figure below for proper orientation.

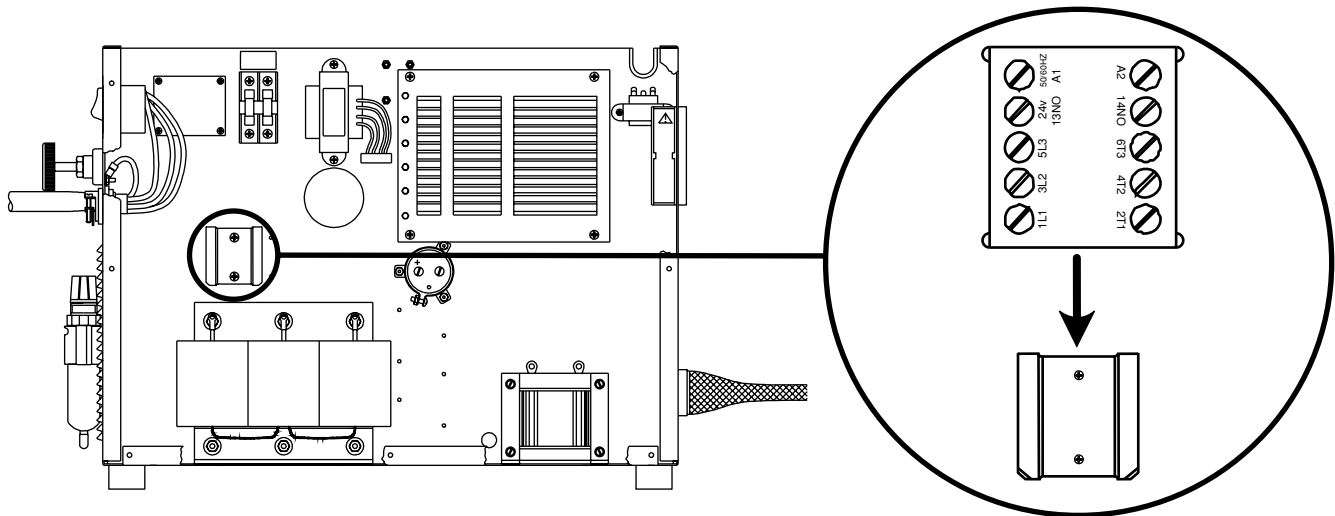

⑥ Connect wires to new contactor.

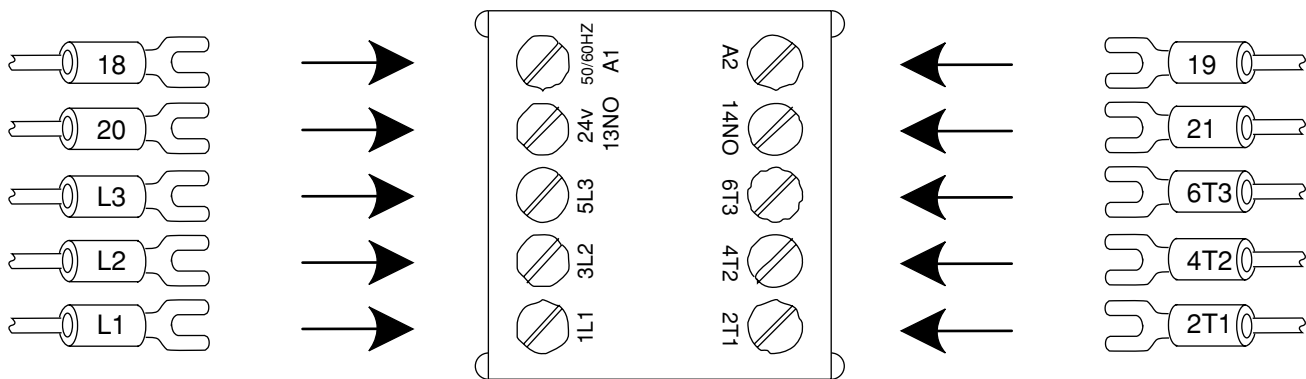

⑦ Re-install power supply cover.

