

MAX40

Torch Conversion

Instruction Manual
800950 - Rev. 0

HYPERTHERM[®]

MAX40
Torch Conversion
Instruction Manual
IM-95

Revision 0 March 1990

Hypertherm, Inc.
P.O. Box A-10 Etna Road
Hanover, New Hampshire 03755
(603) 643-3441

© Hypertherm, Inc., 1990
All Rights Reserved

Hypertherm Offices Worldwide:

Hypertherm, Inc.

Etna Road, P.O. Box 5010
Hanover, NH 03755 USA
Tel.: (603) 643-3441 (Main Office)
Fax: (603) 643-5352 (All Departments)
Tel.: (800) 643-9878 (Technical Service – toll-free in USA and Canada)
Tel.: (800) 737-2978 (Customer Service – toll-free in USA and Canada)
email: info@hypertherm.com (General Information)
email: service@hypertherm.com (Technical/Customer Services)

Hypertherm Plasmatechnik GmbH

Technologiepark Hanau
Rodenbacher Chaussee 6
D-63457 Hanau-Wolfgang, Germany
Tel.: 49 6181 58 2100
Fax: 49 6181 58 2134

Hypertherm (S) Pte Ltd

No. 19 Kaki Bukit Road 2
K.B. Warehouse Complex
Singapore 417847
Tel.: 65 841 2489
Fax: 65 841 2490

Hypertherm UK Ltd

9 Berkeley Court, Manor Park
Runcorn, Cheshire, England WA7 1TQ
Tel.: 44 1928 579 074
Fax: 44 1928 579 604

France

15 Impasse des Rosiers
95610 Eragry, France
Tel.: 33 1 30 37 15 28
Fax: 33 1 30 37 15 79

Hypertherm S.r.L.

Via Torino 2
20123 Milan, Italy
Tel.: 39 02 725 46 312 (Customer Service)
Tel.: 39 02 725 46 314 (Technical Service)
Fax: 39 02 725 46 400 (All Departments)

Hypertherm B.V.

Burg, Haverkampstraat 13
7091 CN Dinxperlo, The Netherlands
Tel.: 31 315 655 866 (Customer Service)
Fax: 31 315 655 886

European Technical Support Organization (ETSO)

Edisonstraat 12
3281 NC Numansdorp, The Netherlands
Tel.: 00 800 4973 7843 (00 800 Hypertherm) – (toll-free Technical Service)
Tel.: 31 186 659494
Fax: 31 186 659495

Japan

Shinjuku Park Tower
30th Floor
3-7-1 Nishi-Shinjuku
Shinjuku-ku, Tokyo
163-1030, Japan
Tel.: 81 03 5326 3142
Fax: 81 03 5326 3001

MAX40 TORCH CONVERSION

Purpose

The MAX40 torch conversion instructions provide the necessary information to allow a person to remove the 75° hand torch from the torch lead and replace it with the PAC140 hand torch.

Customer-Supplied Tools and Items

5/64" Hex wrench
7/16" Open-end wrench
5/16" Open-end wrench
#2 Phillips head screwdriver
Razor knife
Wire cutters
Stakon crimping tool
Electrical tape
Talcum powder

PAC140 Torch Kit (# 057114)

Torch body, # 020479
Torch boot, # 001260
Torch handle, # 001214
Torch handle screws (5), # 027130
Torch switch, # 005094
Wire splicers (2), # 074069
Lead insulator, # 004302

MAX40 TORCH CONVERSION

Procedure

To remove the 75° hand torch from the torch lead, proceed as follows:

1. See Figure A (1). Using the razor knife, start cutting the shrink tubing at the edge away from the torch handle. While cutting the tubing in the direction of the handle, pull back on the tubing to expose the tubing under the handle.
2. See Figure A (2). Using the razor knife, cut away the electrical tape securing the torch lead protective sheath to the torch hoses and switch leads.

Caution: Use care when cutting the shrink tubing and electrical tape, so as not to cut the cathode and pilot arc hose and switch lead insulation.

3. See Figure B (3). Pull the torch lead protective sheath back from the torch handle about six (6) inches.
4. See Figure B (4). Using the wire cutters, cut the switch leads flush with the hole below the switch holder.
5. Ensure the cut switch leads slide back into the hole. If required, pull the torch handle slightly forward; the switch leads should slide back into the hole.
6. See Figure B (5). Using the 5/64" hex wrench, turn the three (3) set screws counter clockwise (ccw) to loosen the torch handle from the torch body.

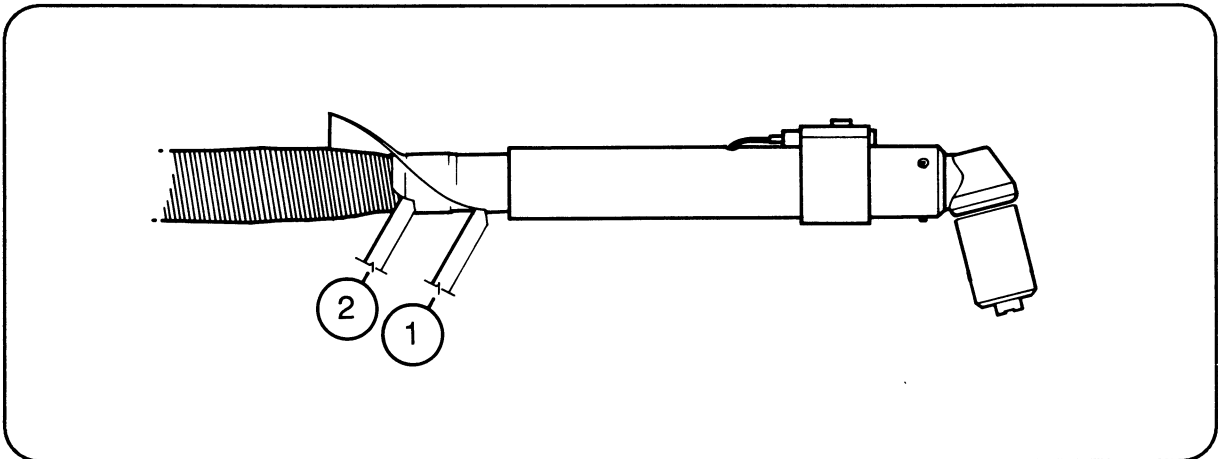

Figure A

MAX40 TORCH CONVERSION

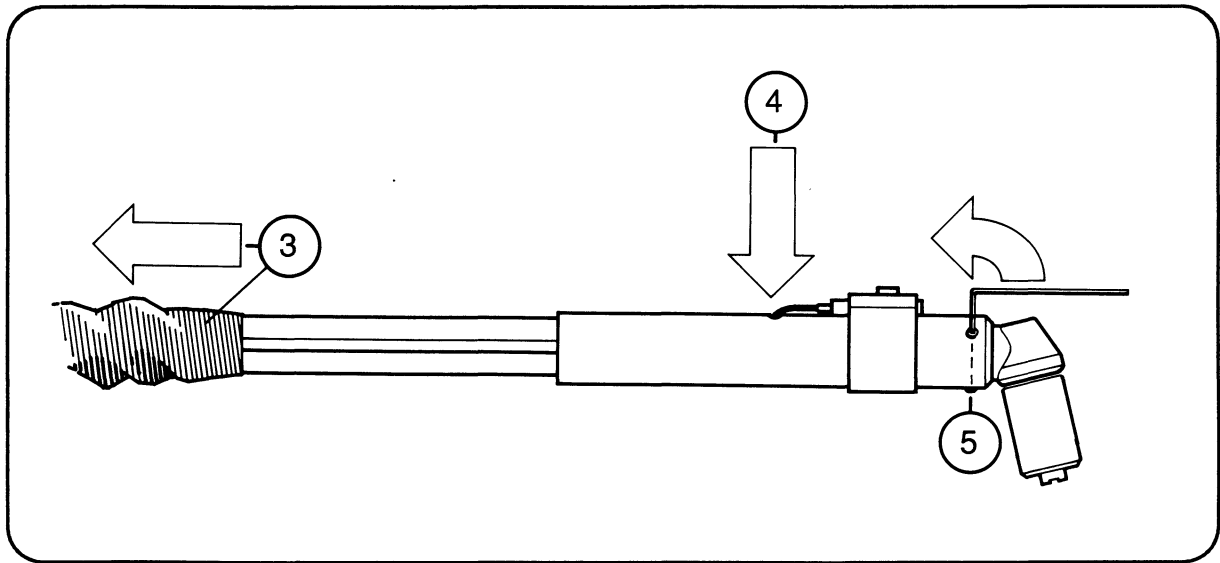

Figure B

7. See Figure C (6). Pull the torch handle back until the insulator tubing covering the pilot arc and cathode hose fittings are exposed.
8. See Figure C (7). Slide the lead insulator covering the cathode hose fitting away to expose the fitting.

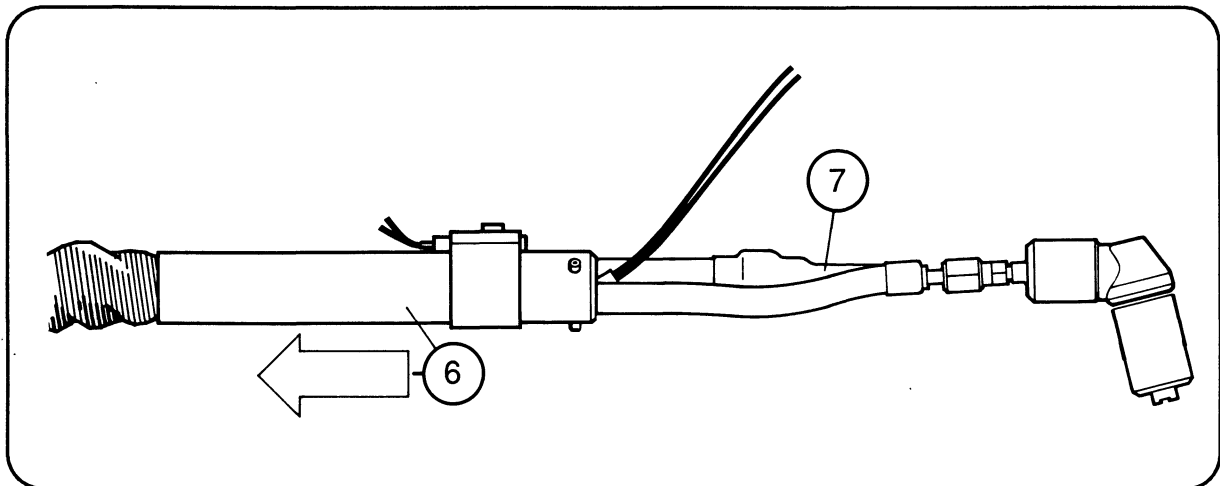

Figure C

MAX40 TORCH CONVERSION

9. See Figure D (8). Disconnect the pilot arc hose (gray) from the torch body. Use the 5/16" open end wrench to hold the torch body fitting (black arrow). Turn the 7/16" open-end wrench on the pilot arc hose fitting (white arrow) counter clockwise (ccw) to loosen the connection.
10. See Figure D (9). Disconnect the cathode hose (blue) from the torch body. Use the 5/16" open-end wrench to hold the torch body fitting (black arrow). Turn the 7/16" open-end wrench on the cathode hose fitting (white arrow) counter clockwise (ccw) to loosen the connection.
11. See Figure D (10). After the torch body has been removed, slide the lead insulator, torch handle, and switch holder with the switch off of the torch lead. (**Do not reuse the parts; save the torch body for use in step 3, page 6.**)
12. See Figure E (11). Position the torch lead protective sheath five (5) inches back from the end of the cathode hose fitting (large hose). Using the electrical tape (12), tape the protective sheath and the hoses and switch leads together.

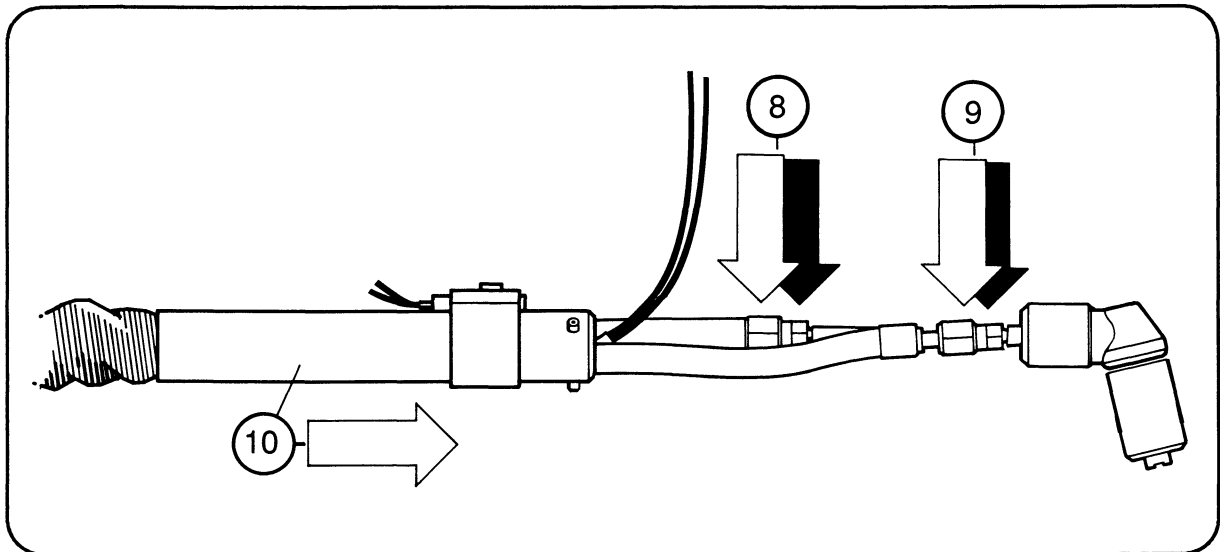

Figure D

To install the PAC140 torch, locate all the parts in the kit and proceed as follows:

1. See Figure F (13). Align the hoses so that they are not twisted. Using the electrical tape, tape the hoses and switch leads together.

Note: The small diameter of the boot is tapered and the opening is slotted. This makes installing the boot over taped hoses a little difficult in steps 2 through 4. If desired, sprinkle talcum powder on the inside of the boot to allow the boot to slide more easily.

2. See Figure F (14). Insert the boot (large diameter end first) on over the taped torch hoses and switch leads. Pull the boot down until the longest hose extends out from the small diameter end.

MAX40 TORCH CONVERSION

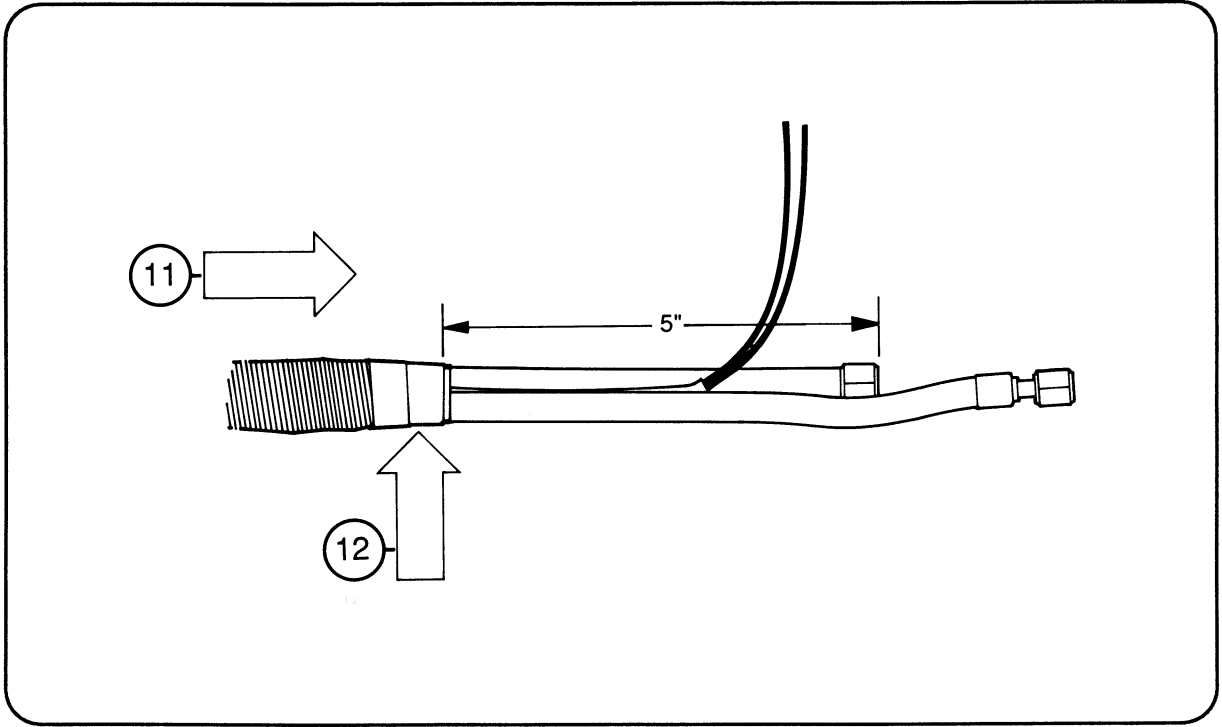

Figure E

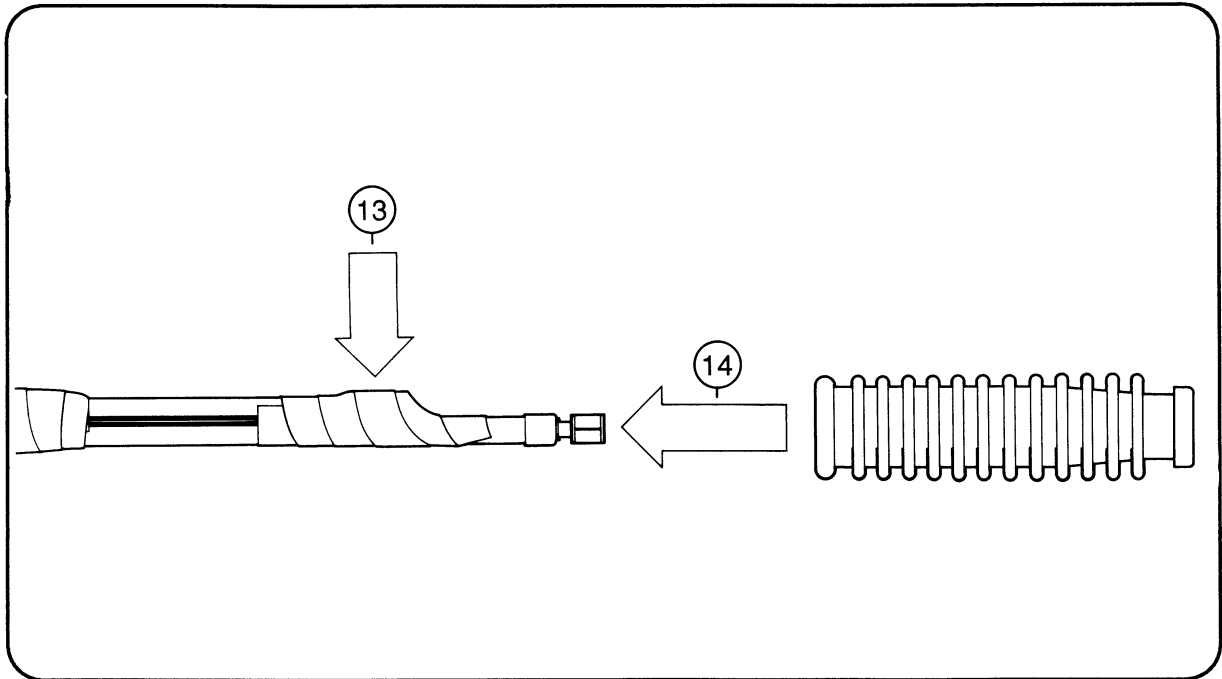

Figure F

MAX40 TORCH CONVERSION

3. See Figure G (15). Connect the removed torch body to the hose fitting. Align the hoses with the slotted opening on the boot.
4. See Figure G (16). Pull on the torch body and boot simultaneously until the taped hoses and switch lead extend out of the boot. Remove the electrical tape (17).

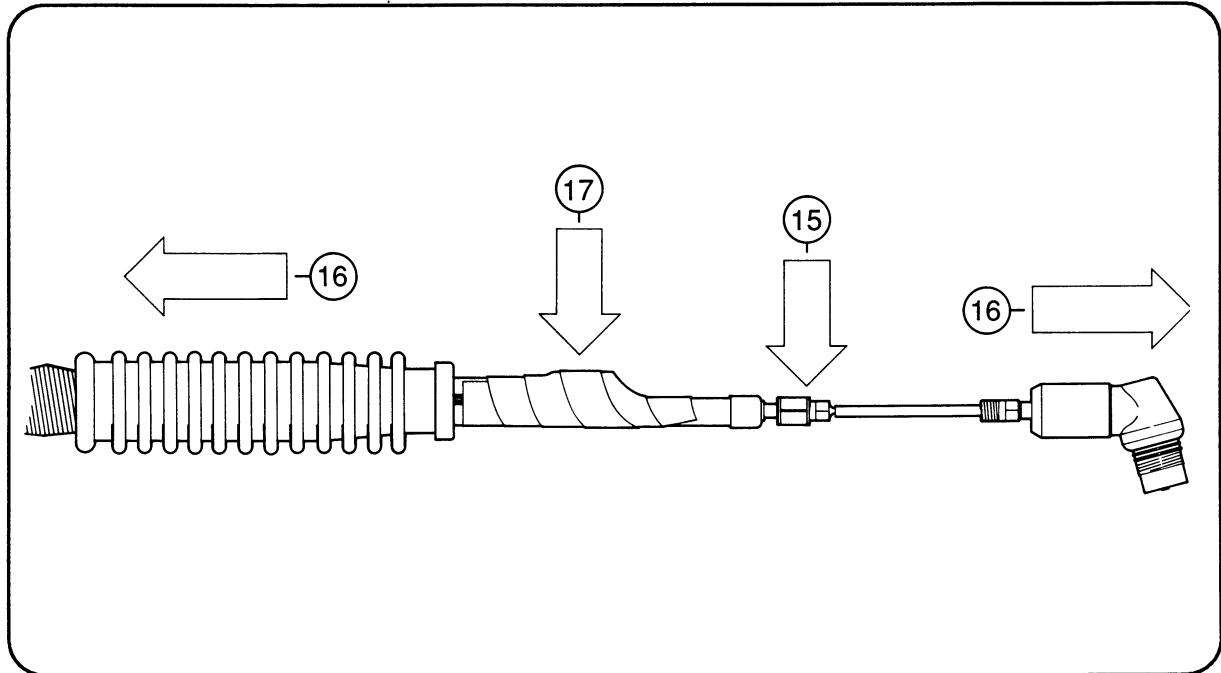

Figure G

5. See Figure H (18). Position the boot so that 2-1/2 inches exists between the boot and the end of the hose. Insert the lead insulator (19) on to the hose and slide past the fittings.
6. See Figure I (20). Connect the cathode hose (blue) to the torch body. Use the 5/16" open-end wrench to hold the torch body fitting (black arrow). Turn the 7/16" open-end wrench on the cathode hose fitting (white arrow) clockwise (cw) to tighten the connection.
7. See Figure I (21). Connect the pilot arc hose (gray) to the torch body. Use the 5/16" open-end wrench to hold the torch body fitting (black arrow). Turn the 7/16" open-end wrench on the cathode hose fitting (white arrow) clockwise (cw) to tighten the connection.
8. See Figure I (22). Slide the lead insulator over the hose fittings. Ensure the fittings are completely covered by the insulator.
9. See Figure I (23). Cut the wire splicers off of the switch leads. **Do not** cut these leads any shorter. **Always** cut the switch leads that are on the replacement torch switch, so that the combined length of the switch leads allows the top of the switch to touch the bottom of the torch body. **If the switch leads are left longer, the switch leads could be pinched when pressing the handle halves together.**

MAX40 TORCH CONVERSION

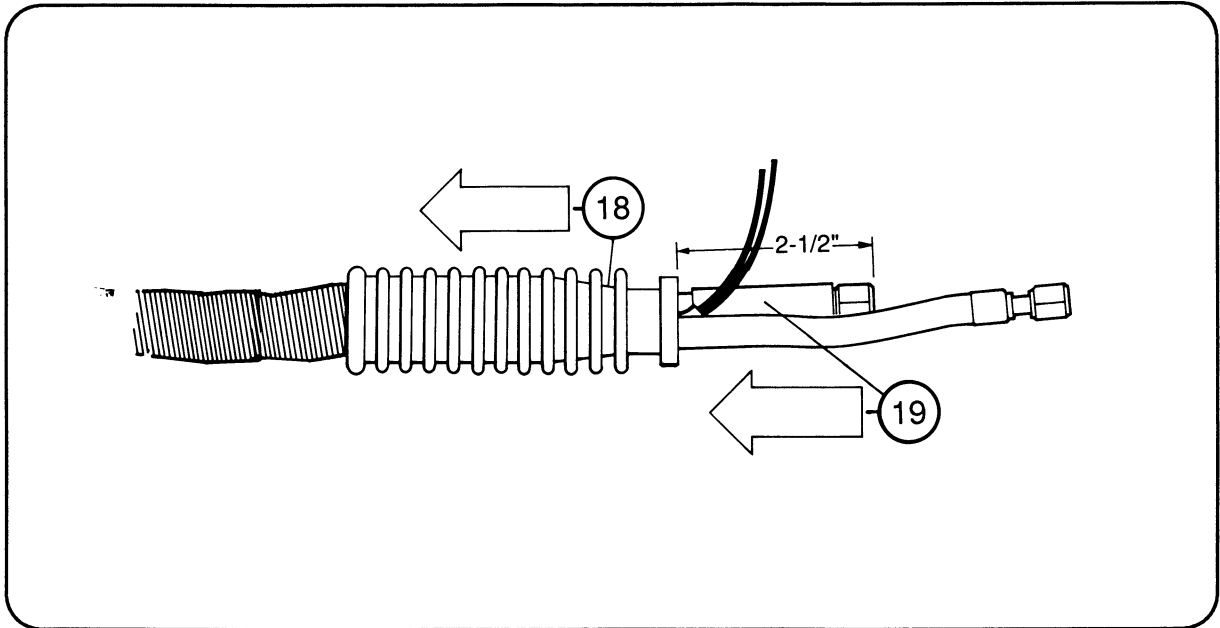

Figure H

10. See Figure I (23). Strip back the insulation from the switch leads 1/4 inch. Splice the switch leads together using the two (2) wire splicers. Insert one of the leads from the switch in one end of the wire splicer and insert one of leads (with the torch lead) in the other end. Secure the wire splicer connections by crimping. Repeat the step to splice the other two switch leads.

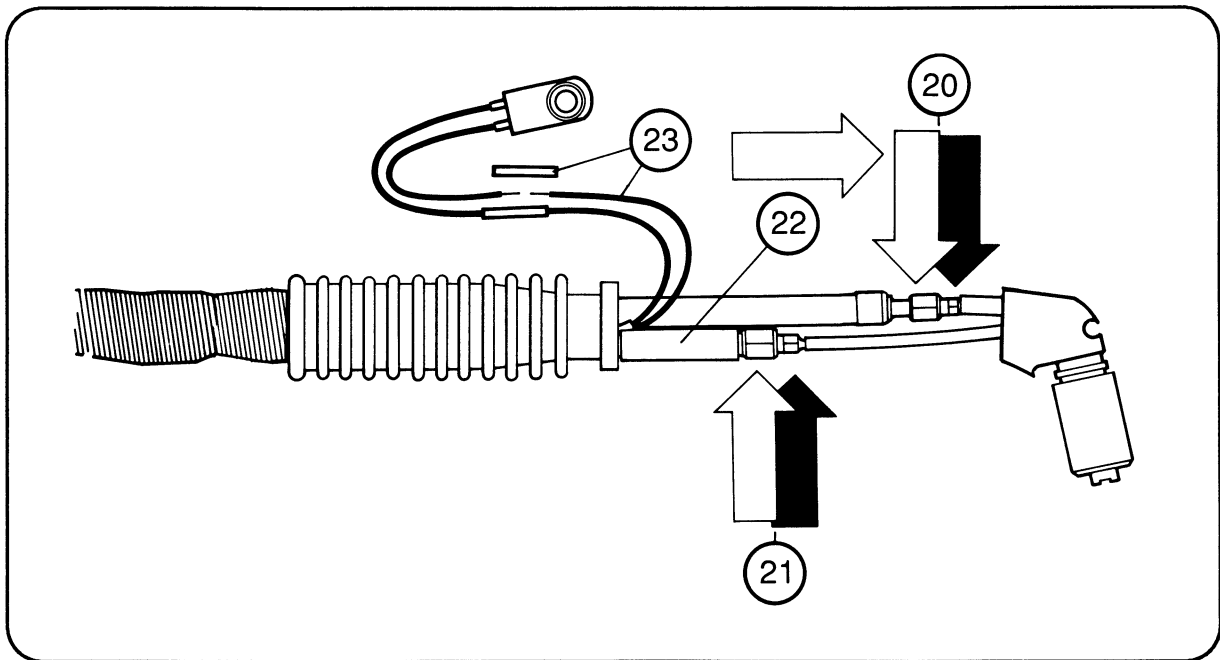

Figure I

MAX40 TORCH CONVERSION

11. See Figure J (24). Insert the torch body into one of the torch handle halves by aligning the torch body flange to the slot at the top of the handle and then pressing into place.
12. See Figure J (25). Insert the torch switch in to the torch handle switch holder. Carefully position the excess length of the switch leads as shown in the figure.
13. See Figure J (26). Insert the top rib of the boot in to the handle just above the screw holes.
14. Align both halves of the torch handle, press together, and secure with the five (5) screws.

Caution: Ensure the switch leads and insulator tubing are out of the way and cannot be pinched when pressing the handle halves together.

15. See Figure K. The torch conversion has been completed.

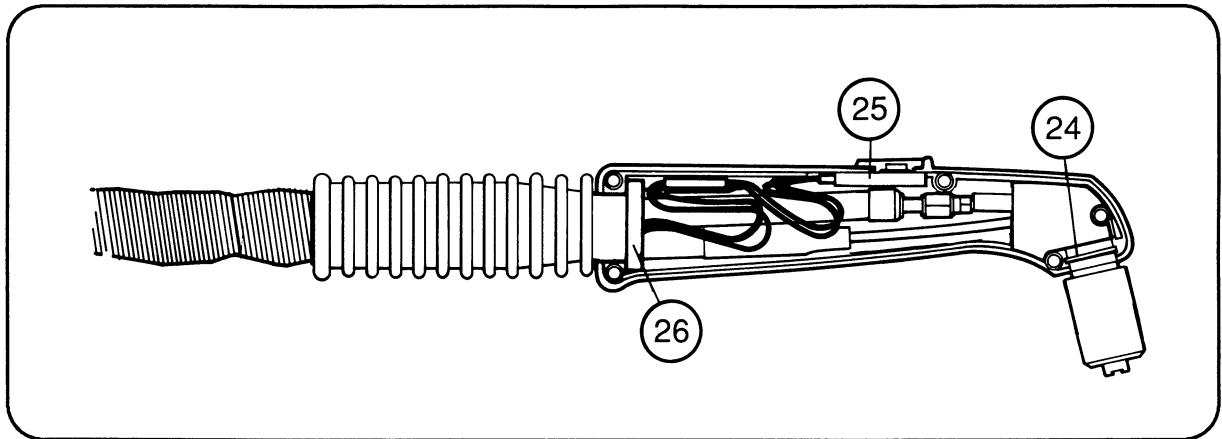

Figure J

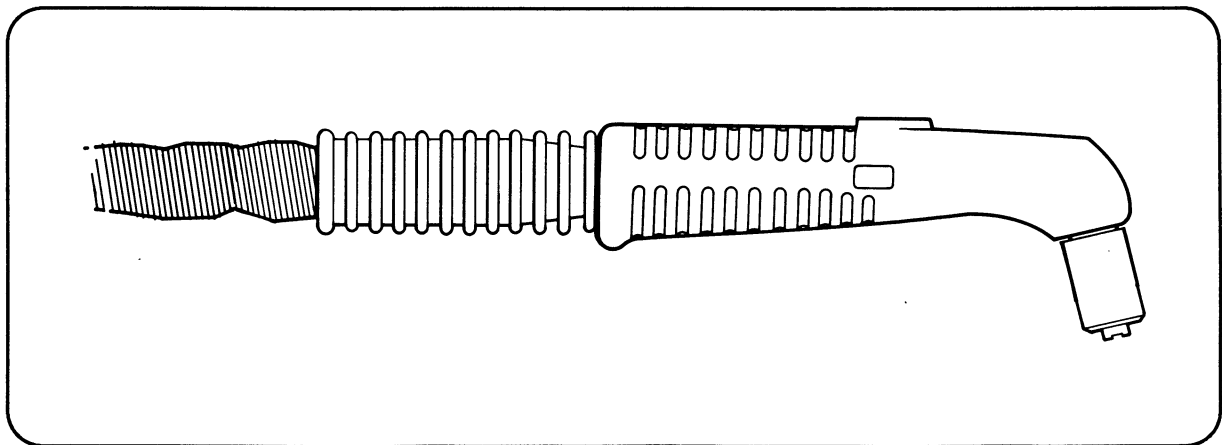

Figure K

