

# ***HT2000 / MAX200***

***Water  
Muffler***

***Instruction Manual  
802050 - Rev. 4***

***Hypertherm***  
*The world leader in  
plasma cutting technology*

# ***HT2000 / MAX200*** **Water Muffler**

## **Instruction Manual**

**(P/N 802050)**

**Revision 4 October, 2013**

**HYPERTHERM, Inc.  
P.O. Box 5010  
Hanover, New Hampshire 03755-5010  
Tel.: (603) 643-3441  
Fax: (603) 643-5352  
<http://www.hypertherm.com>  
[email:info@hypertherm.com](mailto:info@hypertherm.com)**

**© Copyright 2013 Hypertherm, Inc.  
All Rights Reserved**

**Hypertherm, HyDefinition, HT, HyLife, LongLife, MAX, PAC and Powermax are trademarks of Hypertherm, Inc.,  
and may be registered in the United States and/or other countries**

**Hypertherm, Inc.**  
Etna Road, P.O. Box 5010  
Hanover, NH 03755 USA  
603-643-3441 Tel (Main Office)  
603-643-5352 Fax (All Departments)  
**800-643-9878 Tel (Technical Service)**  
800-737-2978 Tel (Customer Service)

**Hypertherm Automation**  
5 Technology Drive  
West Lebanon, NH 03755 USA  
603-298-7970 Tel  
603-298-7977 Fax

**Hypertherm Plasmatechnik GmbH**  
Technologiepark Hanau  
Rodenbacher Chaussee 6  
63457 Hanau-Wolfgang, Deutschland  
49 6181 58 2100 Tel  
49 6181 58 2134 Fax  
**49 6181 58 2123 (Technical Service)**

**Hypertherm Singapore Pte Ltd**  
No. 19 Kaki Bukit Road 2  
K.B. Warehouse Complex  
Singapore 417847, Republic of Singapore  
65 841 2489 Tel  
65 841 2490 Fax  
**65 841 2489 (Technical Service)**

**Japan**  
1952-14 Yata-Natsumegi  
Mishima City, Shizuoka Pref.  
411-0801 Japan  
81 0 559 75 7387 Tel  
81 0 559 75 7376 Fax

**Hypertherm UK Ltd**  
9 Berkeley Court, Manor Park  
Runcorn, Cheshire, England WA7 1TQ  
44 1928 579 074 Tel  
44 1928 579 604 Fax

**France**  
15 Impasse des Rosiers  
95610 Eragny, France  
0805 050 111 Tel  
0805 050 222 Fax

**Hypertherm S.r.L.**  
Via Torino 2  
20123 Milano, Italia  
39 02 725 46 312 Tel  
39 02 725 46 400 Fax  
**39 02 725 46 314 (Technical Service)**

**Hypertherm B.V.**  
Burg. Haverkampstraat 13  
7091 CN Dinxperlo, Nederland  
31 315 655866 Tel  
31 315 655886 Fax

**Hypertherm B.V. (ETSO)**  
Vaartveld 9  
4704 SE Roosendaal, Nederland  
**00 800 49 73 7843 – toll-free in Europa**  
31 165 596900 Tel  
31 165 596901 Fax

**Hypertherm Brasil Ltda.**  
Rua Visconde de Santa Isabel, 20 – Sala 611  
Vila Isabel, RJ  
Brasil CEP 20560-120  
55 21 2278 6162 Tel  
55 21 2578 0947 Fax

## TABLE OF CONTENTS

---

<b>SECTION 1 SAFETY, INTRODUCTION &amp; SPECIFICATIONS</b> .....	<b>1-1</b>
Safety .....	1-2
Introduction .....	1-3
Above-Water Cutting .....	1-3
Underwater Cutting .....	1-3
System Components .....	1-3
Water Table Requirements .....	1-3
Specifications .....	1-4
<b>SECTION 2 INSTALLATION</b> .....	<b>2-1</b>
Upon Receipt .....	2-2
HT2000/MAX200 Water Muffler System with Hoses .....	2-2
HT2000/MAX200 Water Muffler System without Hoses .....	2-2
Damage Claims .....	2-3
Installation .....	2-3
Install the Nozzle Assembly .....	2-3
Position and Connect the Pump to the Water Table .....	2-6
Connect the Pump to the Nozzle Assembly .....	2-6
Connect the Pump to the HT2000 .....	2-6
Connect the Pump to the MAX200 .....	2-9
Test the System .....	2-9
Pump Discharge Hose Water Recovery Checkout .....	2-10
Install Check Valve .....	2-10
<b>SECTION 3 OPERATION &amp; MAINTENANCE</b> .....	<b>3-1</b>
Operation .....	3-2
Above-Water Cutting/Underwater Cutting .....	3-2
Maintenance .....	3-3
Pump Unit .....	3-3
Suction Filter/Strainer .....	3-3
Pump Contactor .....	3-3
Pump Contactor 120VAC Control Signal .....	3-3
Nozzle Assembly .....	3-3
Removal and Replacement Procedures .....	3-4
Remove the Nozzle Assembly from the Torch .....	3-4
Disassemble the Nozzle Assembly .....	3-5
Replace the Nozzle Assembly .....	3-6
Technical Questions .....	3-6
<b>SECTION 4 STANDARD COMPONENTS</b> .....	<b>4-1</b>
Water Muffler System 240/480V, 3PH, 60 Hz w/Hoses .....	4-2
Water Muffler System 240/480V, 3PH, 60 Hz w/o Hoses .....	4-2
Water Muffler System 380-415V, 3PH, 50 Hz w/Hoses .....	4-3

## TABLE OF CONTENTS

---

Water Muffler System 380-415V, 3PH, 50 Hz w/o Hoses .....	4-3
Water Muffler System 600V, 3PH, 60 Hz w/Hoses .....	4-4
Water Muffler System 600V, 3PH, 60 Hz w/o Hoses .....	4-4
Nozzle Assembly, W-M, HT2000/MAX200 .....	4-5
Water Supply, W-M, HT2000/MAX200 .....	4-6
Water Muffler Pump Assembly .....	4-7
HT2000 Water Muffler Pump Cable .....	4-8
Pump Discharge Hose Check Valve (Optional) .....	4-8
<b>APPENDIX</b> .....	<b>a-1</b>
Water Muffler Pumps .....	a-2

## ILLUSTRATIONS

Figure 2-1	Nozzle Assembly Installation .....	2-5
Figure 2-2	Suction/Filter Strainer, Optional Installation .....	2-7
Figure 2-3	Water Muffler System Interconnection Diagram .....	2-8
Figure 3-1	Nozzle Assembly Removal and Replacement .....	3-4
Figure 3-2	Assemble/Disassemble the Nozzle Assembly .....	3-5
Figure 4-1	Nozzle Assembly .....	4-5
Figure 4-2	Water Supply Assembly .....	4-7
Figure 4-3	HT2000 Water Muffler Pump Cable - PS to WM .....	4-8

## Section 1

# Safety, Introduction & Specifications

*In this section:*

---

Safety .....	1-2
Introduction .....	1-3
Above-Water Cutting .....	1-3
Underwater Cutting .....	1-3
System Components .....	1-3
Water Table Requirements .....	1-3
Specifications .....	1-4

### SAFETY

#### WARNING



##### **ELECTRIC SHOCK CAN KILL.**

- Do not touch live electrical parts.
- Keep all panels and covers in place when the machine is connected to a power source.
- Insulate yourself from work and ground: wear insulating gloves, shoes and clothing.
- Keep gloves, shoes, clothing, work area, torch, and this machinery dry.



##### **EXPLOSION WILL RESULT IF PRESSURIZED CONTAINERS ARE CUT.**



##### **ARC RAYS CAN INJURE EYES AND BURN SKIN.**

- Wear correct eye and body protection.



##### **NOISE CAN DAMAGE HEARING.**

- Wear correct ear protection.



##### **FUMES AND GASES CAN INJURE YOUR HEALTH.**

- Keep your head out of the fumes.
- Provide ventilation, exhaust at the arc, or both to keep the fumes and gases from your breathing zone and the general area.
- If ventilation is inadequate, use an approved respirator.



##### **HEAT, SPLATTER AND SPARKS CAUSE FIRE AND BURNS.**

- Do not cut near combustible material.
- Do not cut containers that have held combustibles.
- Do not have on your person any combustibles such as a butane lighter or matches.
- Pilot arc can cause burns. Keep the torch nozzle away from yourself and others when the switch is depressed.
- Wear correct eye and body protection.

## **INTRODUCTION**

The HT2000/MAX200 Water Muffler is a plasma cutting torch option which greatly improves the plasma cutting system's safety and pollution control capabilities. The Water Muffler system can be used to cut both above and below water.

### **Above-Water Cutting**

When used above water (material at the water line), the system becomes an effective pollution control attachment which substantially reduces noise levels, ultraviolet radiation, glare, and airborne particulates. Noise levels less than 95 dBA can be expected when cutting with oxygen to a maximum current of 200A.

### **Underwater Cutting**

Underwater operation provides the maximum possible noise suppression over the widest possible range of current levels. Less than 70 dBA can be expected when cutting three inches or more below the surface of the water.

### **System Components**

Refer to the *Installation* section, *Upon Receipt*, for a list of the HT2000/MAX200 Water Muffler System components.

### **Water Table Requirements**

The Water Muffler must be used in conjunction with the Water Table Pollution Control System. When cutting above water, the water level in the Water Table should be up to or slightly above the bottom surface of the workpiece. The water reservoir located beneath the plate prevents the high-intensity sound waves from escaping out the underside of the workpiece.

When the Water Muffler is used below water, the water level in the Water Table must be three inches or more above the top surface of the workpiece.

The Water Muffler System significantly cools the smoke and fumes generated by plasma cutting (especially when cutting underwater). Proper ventilation and fume extraction near the surface of the Water Table is required.



## SAFETY, INTRODUCTION & SPECIFICATIONS

---

### SPECIFICATIONS

#### Pump\*

##### Input Power:

- # 031006 ..... Pump (3/4 DL) assembly with motor, 2 HP, 3500 RPM 240/480, 3 PH, 60 Hz
- # 031088 ..... Pump (3/4 DL) assembly with motor, 2HP, 3500 RPM 380-415V, 3 PH, 50 Hz
- # 031089 ..... Pump (3/4 DL) assembly with motor, 2HP, 3500 RPM 600V, 3 PH, 60 Hz

**Maximum Working Pressure** ..... 100 psig

**Duty** ..... Continuous

**Direction of Rotation** ..... Clockwise (viewed from motor end)

**Output**..... 9-11 GPM

**Weight** ..... 85 lbs. (includes base and pump contactor box)

**Dimensions** ..... 19" (H) x 11" (W) x 17" (D) (includes base and pump contactor box)

\* Refer to the Appendix for additional pump specifications.

#### Pump Contactor

- # 003017 ..... Contactor, Size 00, 120 VAC

## Section 2

### Installation

In this section:

---

Upon Receipt .....	2-2
HT2000/MAX200 Water Muffler System with Hoses .....	2-2
HT2000/MAX200 Water Muffler System without Hoses .....	2-2
Damage Claims .....	2-3
Installation .....	2-3
Install the Nozzle Assembly .....	2-3
Position and Connect the Pump to the Water Table .....	2-6
Connect the Pump to the Nozzle Assembly .....	2-6
Connect the Pump to the HT2000 .....	2-6
Connect the Pump to the MAX200 .....	2-9
Test the System .....	2-9
Pump Discharge Hose Water Recovery Checkout .....	2-10
Install Check Valve .....	2-10

---

## INSTALLATION

---

### UPON RECEIPT

1. Remove the Water Muffler system and save the carton. The carton is reusable and provides an impact-resistant box for transporting or storing the system and parts. The carton should include either of the following systems:

#### **HT2000/MAX200 Water Muffler System with Hoses**

020423	Cap, HT2000/MAX200 shield
024022	Hose assembly, #12 x 50 ft. with:
015262	Swivel, #12 3/4 Syn hose Brs (attached to hose)(2)
015262	Ferrule, 1.150 ID x .88 Brs (attached to hose)(2)
046020	Hose:3/4" ID Blk
024023	Hose assembly, #12 x 4 ft. with:
015262	Swivel, #12 3/4 Syn hose Brs (attached to hose)(2)
015262	Ferrule, 1.150 ID x .88 Brs (attached to hose)(2)
015052	Adapter, 3/4 NPT x #12 (attached to hose)
027009	Filter, 2" NPT, water
015578	Reducer bushing, 2" x 3/4", galv
015509	Nipple 2" x CL, galv
046020	Hose:3/4" ID Blk
027012	Silicone lubricant
028042	Water supply, W-M, 240/480V, 3PH, 60 Hz (refer to page 4-6)
or	
028299	Water supply, W-M, 380-415V, 3PH, 60 Hz (refer to page 4-6)
or	
028308	Water supply, W-M, 600V, 3PH, 60 Hz (refer to page 4-6)
034148	Nozzle assembly, W-M, HT2000/MAX200 (refer to page 4-5)
020566	Shield, HT2000/MAX200 W-M
020618	Shield, HT2000/MAX200 W-M - 100 Amp

#### **HT2000/MAX200 Water Muffler System without Hoses**

020423	Cap, HT2000/MAX200 shield
015053	Swivel, #12 (3)
015052	Adapter, 3/4 NPT x #12
027009	Filter, 2" NPT, water
015578	Reducer bushing, 2" x 3/4", galv
015509	Nipple 2" x CL, galv
027012	Silicone lubricant
028042	Water supply, W-M, 240/480V, 3PH, 60 Hz (refer to page 4-6)
or	
028299	Water supply, W-M, 380-415V, 3PH, 60 Hz (refer to page 4-6)
or	
028308	Water supply, W-M, 600V, 3PH, 60 Hz (refer to page 4-6)
034148	Nozzle assembly, W-M, HT2000/MAX200 (refer to page 4-5)
020566	Shield, HT2000/MAX200 W-M
020618	Shield, HT2000/MAX200 W-M - 100 Amp

2. Verify that all components are present. Alert your distributor if any parts are missing.
3. Inspect the power supply for any physical damage that may have occurred during shipping. If there is evidence of damage, see the *Damage Claims* section below.

Before operating the Water Muffler system, read the *Safety* and *Operation* sections of this manual.

### Damage Claims

**Claims for damage during shipment** - If your unit was damaged during shipment, you must file a claim with the carrier. Hypertherm will furnish you with a bill of lading upon request. Call our Customer Service group at 1-800-643-0030.

## INSTALLATION

To install the HT2000/MAX200 Water Muffler System, you need to install and interconnect the following units:

- Nozzle Assembly
- Pump Unit



### WARNING



**Turn all power to the HT2000 or MAX200 OFF before installing water muffler!**

### Install the Nozzle Assembly

It is not necessary to disconnect the torch leads from the torch to install the HT2000/MAX200 water muffler nozzle assembly:

1. Turn power to the HT2000 or MAX200 power supply OFF.
2. Remove the shield and shield cap from the HT2000 or MAX200 machine torch.
3. Select correct consumables for cutting with the water muffler system (see chart on following page) and replace, if necessary, all torch consumables except the W-M shield and shield cap.

For further cut chart information, refer to instruction manuals #802070: HT2000 Instruction, or #800980: MAX200 Machine Torch, or #800990: MAX200 Remote High Frequency.

## INSTALLATION

4. Insert the nozzle assembly (#034148) over the torch body keeping the thumb-screw end of the nozzle closest to the torch insulating sleeve (see Figure 2-1).
5. Remove one thumb screw and adjust torch and nozzle assembly together until you locate the groove in the torch body when looking through the threaded thumb screw hole.  
Note: If your torch does not have a groove in the body (older style torches) push on nozzle assembly until it touches the insulating sleeve.
6. Replace the thumb screw and hand-tighten. Tighten the two other thumb screws in place.
7. Install the W-M shield (#020566 or #020618 - refer to chart) on to the shield cap (#020423).
8. Liberally apply a 1/4-inch band of silicon lubricant around the inner (threads) and a 1/4-inch band around the outer circumference of the shield cap (see Figure 2-1).
9. Install the shield cap onto the torch body. (Hand tighten only.)

Power Supply	Amps	Plasma Gas/ Shield Gas	Shield	Shield Cap	Nozzle	Swirl Ring	Electrode
<b>HT2000</b>	<b>200</b>	Air / Air	<b>020566</b>	020423	020608	020679	120667
	<b>100</b>	Air / Air	<b>020618</b>	020423	020611	020607	120547
	<b>200</b>	O <sub>2</sub> / Air	<b>020566</b>	020423	020605	020678	120667
	<b>100</b>	O <sub>2</sub> / Air	<b>020566</b>	020423	020690	020613	120547
	<b>200</b>	N <sub>2</sub> / CO <sub>2</sub>	<b>020566</b>	020423	020608	020607	020415
	<b>200</b>	N <sub>2</sub> / Air	<b>020566</b>	020423	020608	020607	020415
<b>MAX200</b>	<b>200</b>	Air / Air	<b>020566</b>	020423	020608	020607	120667
	<b>100</b>	Air / Air	<b>020618</b>	020423	020611	020607	120547
	<b>200</b>	O <sub>2</sub> / Air	<b>020566</b>	020423	020605	020604	120667
	<b>100</b>	O <sub>2</sub> / Air	<b>020618</b>	020423	020616	020617	120547
	<b>200</b>	N <sub>2</sub> / CO <sub>2</sub>	<b>020566</b>	020423	020608	020607	020415
	<b>200</b>	N <sub>2</sub> / Air	<b>020566</b>	020423	020608	020607	020415

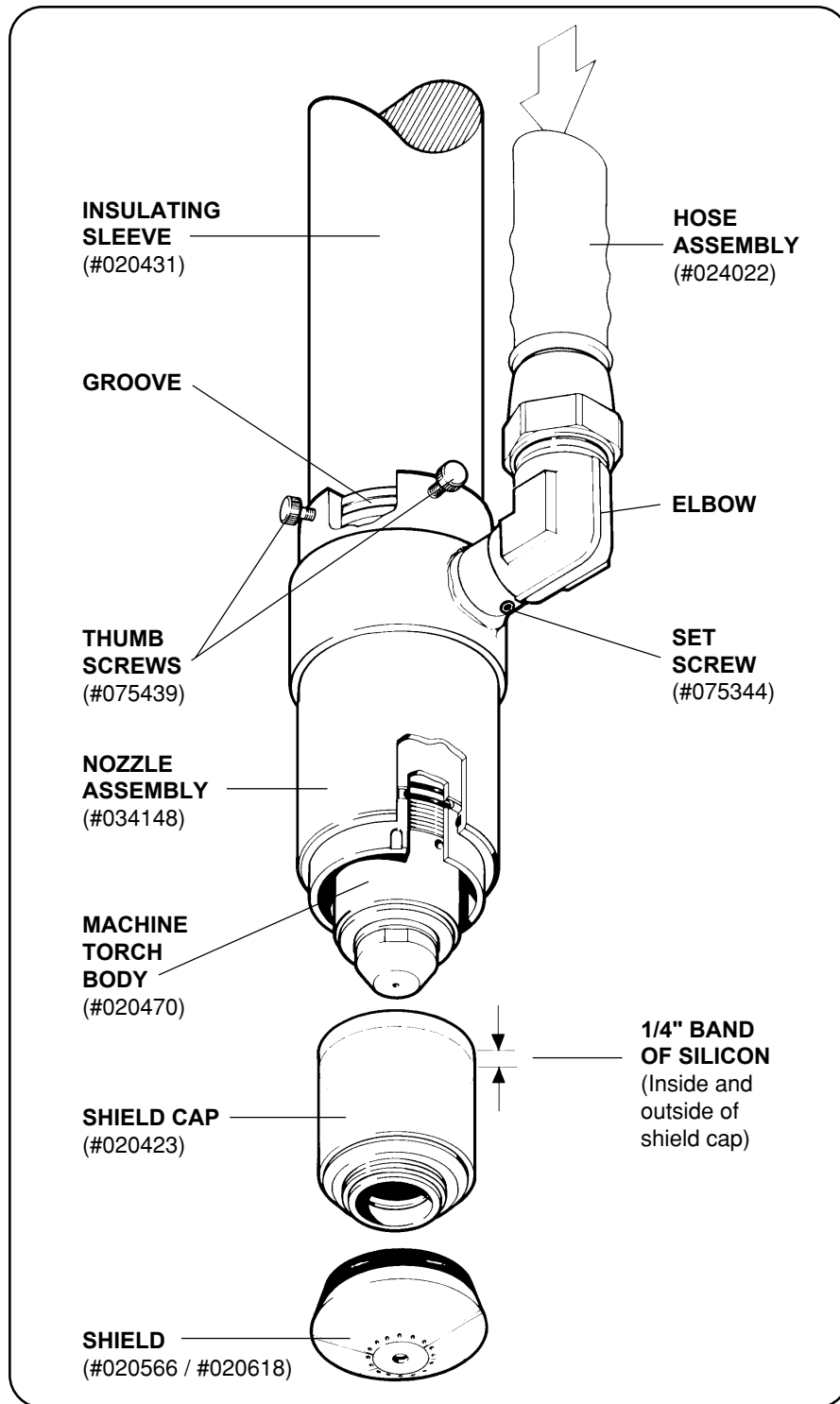

Figure 2-1 Nozzle Assembly Installation

## INSTALLATION

---

### Position and Connect the Pump to the Water Table

1. Place the pump near the Water Table feed port to be used. The pump **must** be below the Water Table Water level in order to properly function.

Note: It is important to place the pump as close as possible to the Water Table. Longer distances can result in pump priming and water lag problems during startup, resulting in excessive noise and smoke during initial starting.

2. Install the suction filter/strainer (#027009) to the Water Table feed port. Figure 2-2 represents an optional installation; the user may wish to use another configuration. The reducer bushing (#015578) and nipple (#015509) are supplied; other required filter/strainer connection and support hardware are customer-supplied.
3. Connect the pump inlet to the filter/strainer assembly using the supplied four-foot hose assembly (#024023). (See Figure 2-3.) If more than four feet of hose is required, use solid tubing (eight feet maximum). If solid tubing is not used in installations of over four feet, the hose could collapse due to the initial suction of the pump at turn on. If solid tubing is to be installed, **do not use PTFE tape**. Use liquid pipe sealant only.

### Connect the Pump to the Nozzle Assembly

Route the pump discharge hose assembly (# 024022) from the pump to the nozzle assembly through the power track or festoon system. In no case should the discharge hose be longer than 80 feet (24.4 m). The elbow on the nozzle can swivel for easy access. Tighten with set screw (see Figure 2-1).

Note: If the discharge hose is routed in an overhead festoon system, a check valve may be required. To determine if a check valve is needed, refer to the *Pump Discharge Hose Water Recovery Checkout* at the back of this section.



#### WARNING



Turn all power to the HT2000 or MAX200 OFF before connecting pump to power supply!

### Connect the Pump to the HT2000

1. Make all electrical connections as detailed in Figure 2-3. The pump should be electrically installed by an experienced electrician in compliance with the specifications of national or international electrical codes. The motor is provided with overload protection.

## INSTALLATION

- To connect pump to HT2000 with either the 50 ft (#023445) or 75 ft (#023617) cables, attach wire from pin 2 (AC Hot - black) to coil, wire from pin 4 (AC Neutral - white) to neutral, and wire from pin 3 (Ground - green) to ground.
- Connect plug end of cable to the rear of HT2000 power supply at receptacle **WATER MUFFLER 1X10**.

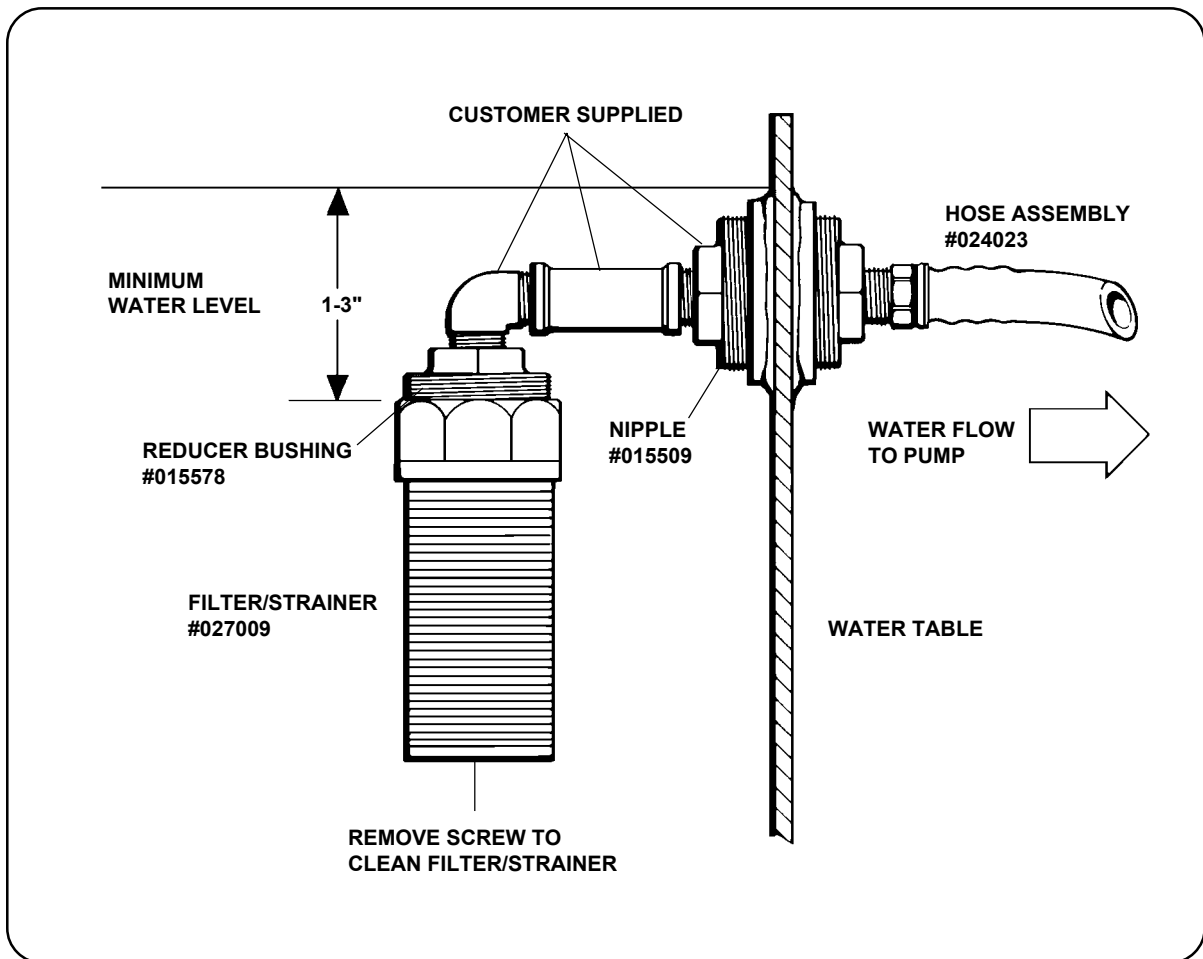

Figure 2-2 Suction Filter/Strainer, Optional Installation



# INSTALLATION

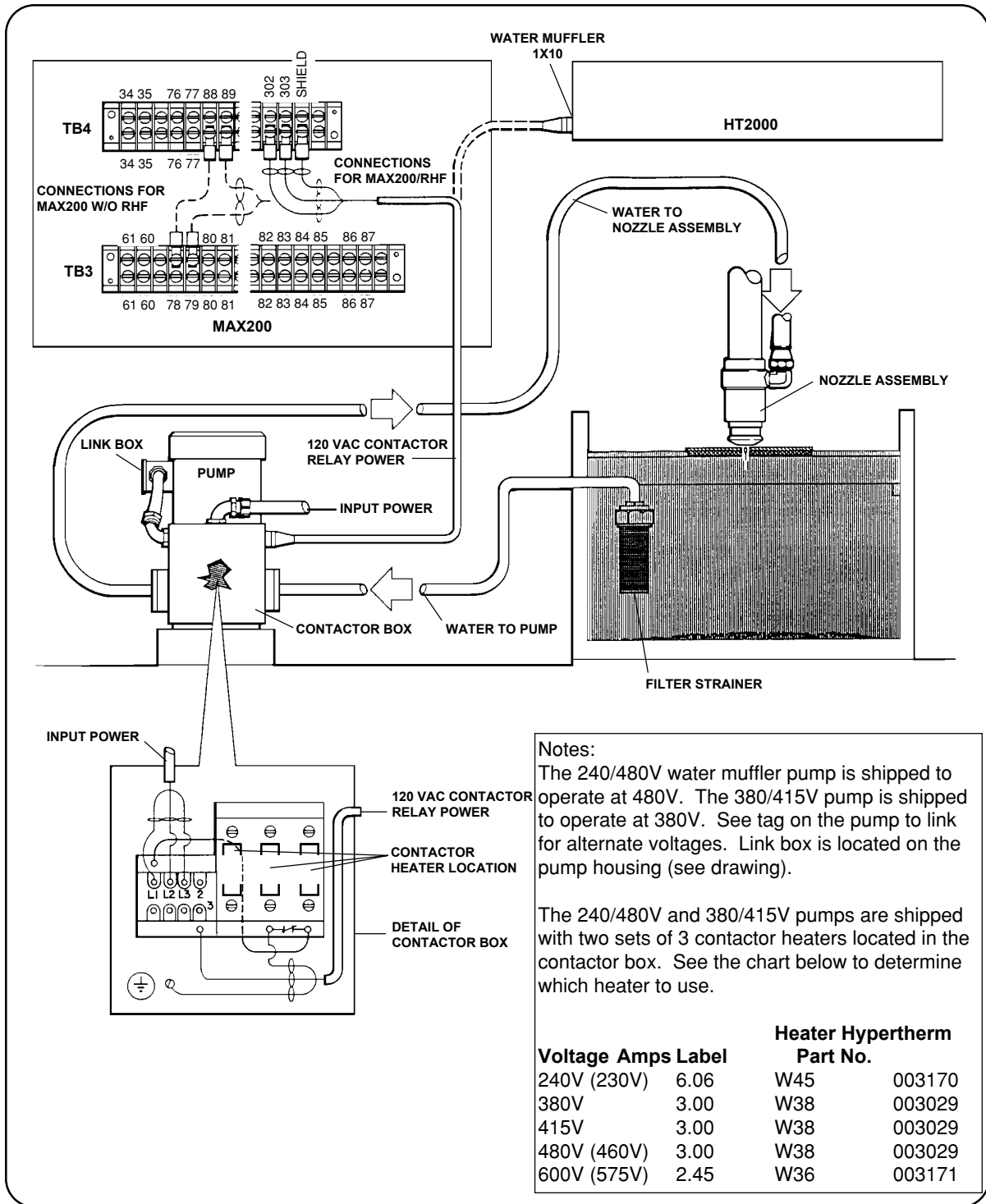

Figure 2-3 Water Muffler System Interconnection Diagram

### Connect the Pump to the MAX200

1. Make all electrical connections as detailed in Figure 2-3. The pump should be electrically installed by an experienced electrician in compliance with the specifications of national or international electrical codes. The motor is provided with overload protection.
2. Connect the water pump contactor to the MAX200 power supply with customer-supplied three-conductor cable (see Figure 2-3).
3. Route the cable through the feed-thru located on rear panel of the power supply.
4. If using the MAX200/RHF power supply, connect the cable to TB4-302 (AC Hot), TB4 -303 (Neutral), and shield. If using a standard MAX200 power supply, connect the cable to TB4-89 (AC Hot) and TB3-79. Also connect a jumper between TB4-88 (Neutral) and TB3-78.

### Test the System

With all power and water connections complete, test the Water Muffler System:

1. Apply primary power to the HT2000 or MAX200 power supply.
2. Be sure that the Water Table water level is high enough to feed the pump (covers the filter intake completely).
3. Check the Water Muffler pump for a proper direction of rotation. To do this, proceed as follows:

<p><b>Caution: Operating the pump in reverse rotation may cause extensive damage.</b></p>
---

- Depress the green POWER ON switch to turn on the HT2000 or MAX200.
  - Depress the plasma start switch. As soon as the pump energizes, depress the red POWER OFF switch.
  - Look for a clockwise pump rotation as viewed from the top of the motor. A direction of rotation arrow is also shown on the side of the pump casing. If the pump rotates in a counter clockwise direction, reverse any two of the 3-phase power leads to the motor.
4. Once the pump rotation is verified correct, energize the pump by depressing the plasma start switch.
    - If the water does not start flowing within 10 to 15 seconds, deenergize the pump.

## INSTALLATION

---

- Prime the pump by removing the water inlet hose and filling the hose with water and then reconnecting the hose.
  - Energize the pump.
5. With water flowing, check for an even flow of water around the torch and for leaks around all connections. Tighten connections as necessary. The water pump will deliver approximately 9 to 11 gallons per minute.

### Pump Discharge Hose Water Recovery Checkout

If the pump discharge hose is routed through an overhead festoon system, a check valve may be required. This can be determined by checking to see if the water from the pump discharge hose drains back through the pump when the water muffler system shuts off, and when the water muffler system restarts, the water does not obtain full flow back to the water muffler before the plasma arc fires. If this condition occurs, a check valve needs to be installed according to the procedure that follows.

### Install Check Valve

Parts required:

- Valve, check, # 034156
- Gland, hose 3/4 NPT X #12 straight (2), # 015052
- Clamp, hose 3/4 - 1-3/4 (2), # 015234

Install the check valve in-line on the pump discharge hose as follows:

1. Cut the pump discharge hose (Fig 2-3) as close to the nozzle assembly as possible to install the check valve. (The check valve should not be installed farther than 6 feet (1.8 m) from the nozzle assembly.)
2. Apply liquid pipe sealant on to the threads of both glands. Screw glands into the ends of the check valve and tighten with wrench.
3. Slide the hose clamps over the ends of the discharge hose. Then slide each end of the hose over the ends of the check valve. Slide the hose clamps over the ends of the check valve and tighten. (The arrow on the check valve indicates the direction of water flow and should point in the direction of the nozzle assembly.)
4. Perform *Test the System* checkout again to ensure proper water muffler operation.

## Section 3

### Operation & Maintenance

*In this section:*

---

Operation .....	3-2
Above-Water Cutting/Underwater Cutting .....	3-2
Maintenance .....	3-3
Pump Unit .....	3-3
Suction Filter/Strainer .....	3-3
Pump Contactor .....	3-3
Pump Contactor 120-VAC Control Signal .....	3-3
Nozzle Assembly .....	3-3
Removal and Replacement Procedures .....	3-4
Remove the Nozzle Assembly from the Torch .....	3-4
Disassemble the Nozzle Assembly .....	3-5
Replace the Nozzle Assembly .....	3-6
Technical Questions .....	3-6

## OPERATION & MAINTENANCE

---

### OPERATION

The HT2000/MAX200 Water Muffler system will start automatically with the initiation of the start signal to the plasma cutting torch. Input power to the pump motor is available in either 240/480V, 3 PH, 60 Hz; 380-415V, 3 PH, 50Hz; or 600V, 3 PH, 60 Hz configurations. The pump contactor coil is energized by a 120VAC signal from the power supply. When the 120VAC contactor circuit is actuated, the pump operates and water flows. The Water Muffler will only operate when the TEST/RUN switch on the MAX200 is in the RUN position. Likewise, the Water Muffler will only operate on the HT2000 system when S2 on the gas console is in the RUN position.

The operating procedures and requirements for above and underwater cutting are as follows:

#### **Above-Water/Underwater Cutting**

1. Ensure the Water Muffler System is installed according to the procedures in *Installation*, Section 2.
2. **Above-Water Cutting**

At the Water Table, ensure the water level is maintained at or slightly above the bottom of the workpiece. If initial height sensing (IHS) is not used, manual torch positioning will be necessary. This is done by lowering the torch to approximately 1/4 inch (6mm) above the top surface of the workpiece.

#### **Underwater Cutting**

At the Water Table, ensure the water level is maintained at three inches or more above the top surface of the workpiece. It is recommended that initial height sensing (IHS) be used when cutting under water. If an IHS system is not used, manually position the torch as in above-water cutting.

3. Apply power to the HT2000 or MAX200 and press the green POWER ON switch. Depress the plasma start switch. A command signal is output to the pump contactor to operate the pump. The water pump delivers approximately 9 to 11 gallons per minute.

### **MAINTENANCE**

To maintain the HT2000/MAX200 Water Muffler System, you must periodically disassemble the Water Muffler and inspect, clean, and/or replace components as required. In the event the pump does not turn on, you must determine if the pump, or the pump contactor is at fault, or the 120VAC pump contactor control signal is missing.

#### **Pump Unit**

If the pump is faulty and requires maintenance, refer to the maintenance instructions for the water muffler pump in the Appendix at the back of this manual. Pump maintenance also includes inspecting all hoses and connections and replacing as needed. The suction filter/strainer should also be checked and cleaned periodically.

#### **Suction Filter/Strainer**

To clean the suction filter/strainer, remove the screw and the plastic cover at the bottom (see Figure 2-2). After cleaning the filter/strainer, replace the cover and screw it back on.

#### **Pump Contactor**

If the pump contactor or 120VAC relay coil is defective, contact an experienced electrician to perform the maintenance.

#### **Pump Contactor 120VAC Control Signal**

If the 120VAC control signal to the pump contactor is missing, refer to Figure 2-3. Refer also to the wiring diagrams in the HT2000 Instruction Manual IM207 (P/N 802070) or the MAX200 electrical schematic provided with the MAX200 Service Manual IM-162 (P/N 801620) to locate the missing control signal.

#### **Nozzle Assembly**

If the nozzle assembly is faulty, refer to the *Removal and Replacement Procedures* to remove parts for cleaning and replacement.

**REMOVAL AND REPLACEMENT PROCEDURES**

**WARNING**

Turn all power to the HT2000 or MAX200 OFF before removing or replacing water muffer!

**Remove the Nozzle Assembly from the Torch**

1. Remove the shield and shield cap from the HT2000 or MAX200 machine torch.
2. Hold the nozzle assembly with one hand, and loosen all three thumb screws with the other hand.
3. Slide the nozzle assembly down away from the machine torch.

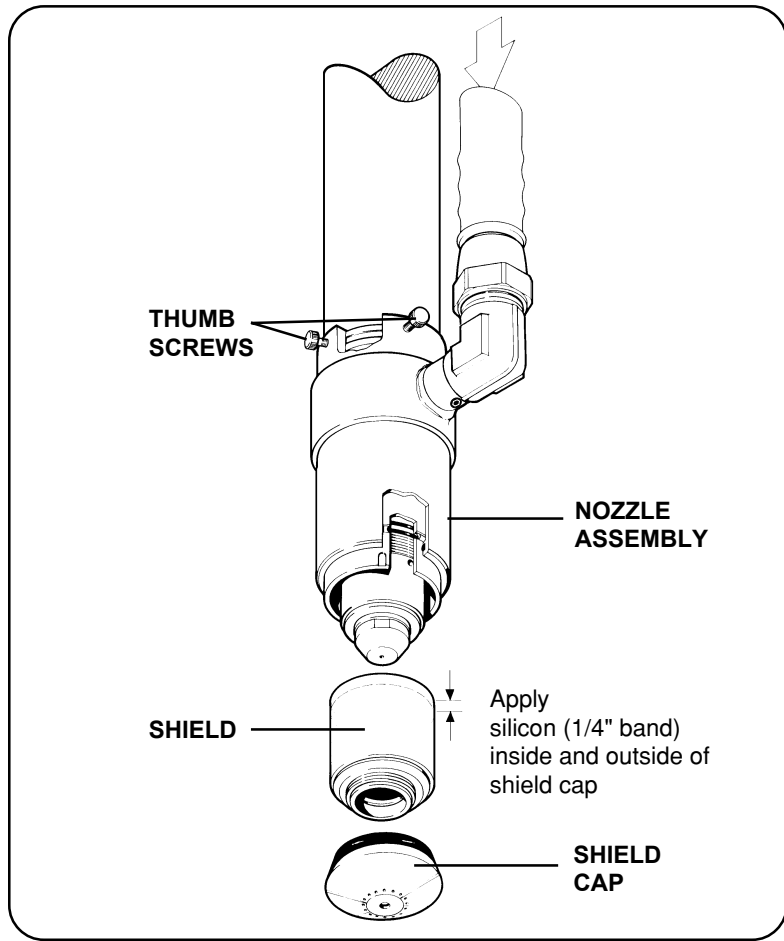
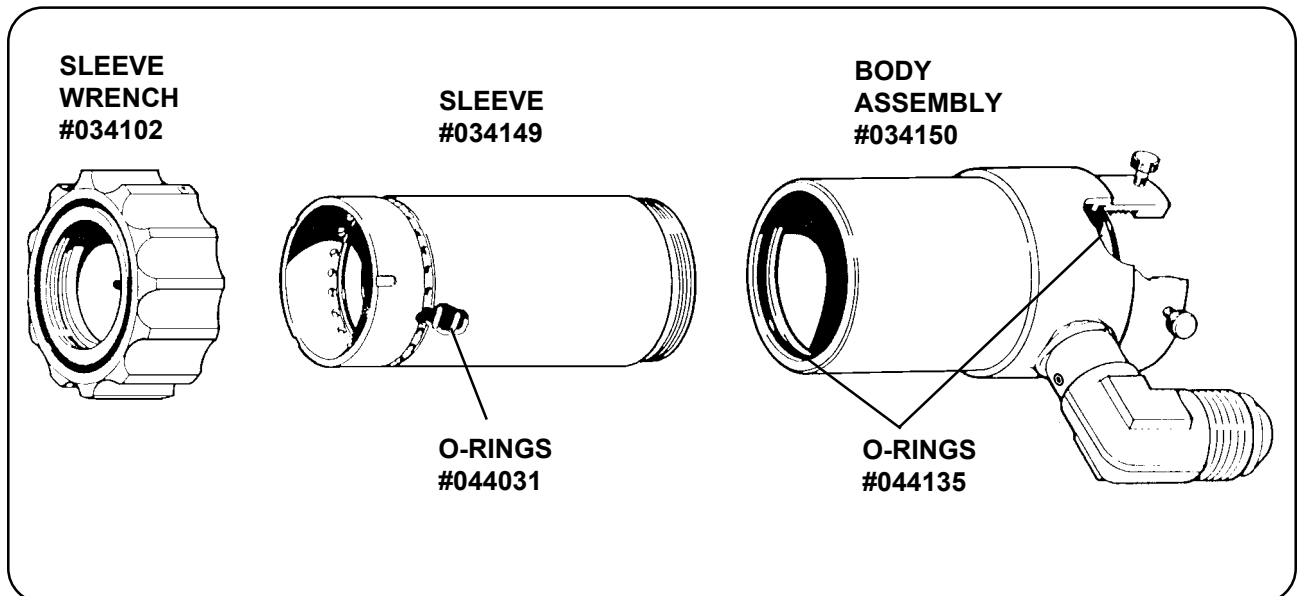

Figure 3-1 Nozzle Assembly Removal and Replacement

**Disassemble the Nozzle Assembly**

1. Insert the sleeve wrench (#034102) over the small diameter end of sleeve (#034149) and turn to lock in place (see Figure 3-2).
2. Remove the sleeve from the body assembly (#034150) by turning the sleeve wrench counterclockwise and pulling.



**Figure 3-2 Assemble/Disassemble the Nozzle Assembly**



## OPERATION & MAINTENANCE

---

### Replace the Nozzle Assembly

#### Assemble the Nozzle Assembly

1. Liberally lubricate the two O-rings (#044031) on the sleeve and the two O-rings (#044135) on the body assembly with the silicon lubricant provided (see Figure 3-2).
2. Insert the sleeve wrench over the small diameter end of sleeve and turn to lock in place.
3. Insert the sleeve into the body assembly by pushing and turning the sleeve wrench clockwise (cw) until the sleeve is completely inserted.

#### Mount the Nozzle Assembly to the Torch

1. Remove one of the thumb screws on the nozzle assembly and slide the nozzle assembly up onto the torch (see Figure 3-1).
2. Adjust the torch and nozzle assembly together until you locate the groove in the torch body when looking through the threaded thumb-screw hole.  
Note: If your torch does not have a groove in the body (older style torches) push on nozzle assembly until it touches the insulating sleeve.
3. Replace the thumb screw and hand-tighten. Tighten the two other thumb screws in place.
4. Liberally apply a 1/4-inch band of silicon lubricant around the inner (threads) and a 1/4-inch band around the outer circumference of the shield cap (see Figure 3-1).
5. Replace the W-M shield and shield cap on to the torch.

## TECHNICAL QUESTIONS

If you are unable to solve a problem after reviewing this manual and the HT2000 instruction manual (IM207) or MAX200 Instruction Manual (IM-98) as well as the associated electrical schematic:

- Call your distributor. He will be able to help you, or refer you to an authorized Hypertherm repair facility.
- If you need additional assistance, call our Customer Service or Field Service group at 1-800-643-0030.

## Section 4

### Standard Components

In this section:

---

Water Muffler System 240/480V, 3PH, 60 Hz w/Hoses .....	4-2
Water Muffler System 240/480V, 3PH, 60 Hz w/o Hoses .....	4-2
Water Muffler System 380-415V, 3PH, 50 Hz w/Hoses .....	4-3
Water Muffler System 380-415V, 3PH, 50 Hz w/o Hoses .....	4-3
Water Muffler System 600V, 3PH, 60 Hz w/Hoses .....	4-4
Water Muffler System 600V, 3PH, 60 Hz w/o Hoses .....	4-4
Nozzle Assembly, W-M, HT2000/MAX200 .....	4-5
Water Supply, W-M, HT2000/MAX200 .....	4-6
Water Muffler Pump Assembly .....	4-7
HT2000 Water Muffler Pump Cable .....	4-8
Pump Discharge Hose Check Valve (Optional) .....	4-8

## STANDARD COMPONENTS

---

### **WATER MUFFLER SYSTEM 240/480V, 3PH, 60 HZ W/HOSES**

Stock No. - 034096

<u>Stock Number</u>	<u>Description</u>	<u>Quantity</u>
020423	Cap, MAX200 shield	1
024022	Hose assembly, #12 x 50 ft. with:	1
015262	Swivel, #12 3/4 Syn hose Brs (attached to hose)	2
015264	Ferrule, 1.150 ID x .88 Brs (attached to hose)	2
046020	Hose:3/4"ID Blk	50'
024023	Hose assembly, #12 x 4 ft. with:	1
015262	Swivel, #12 3/4 Syn hose Brs (attached to hose)	1
015264	Ferrule, 1.150 ID x .88 Brs (attached to hose)	1
015052	Adapter, 3/4 NPT x #12 (attached to hose)	1
027009	Filter, 2" NPT, water	1
015578	Reducer bushing, 2" x 3/4", galv	1
015509	Nipple 2" x CL, galv	1
046020	Hose:3/4"ID Blk	4'
027012	Silicone lubricant	1
028042	Water supply, W-M, MAX200 (refer to page 4-6)	1
034148	Nozzle Assy:200A W-M 90 Deg Ftg (refer to page 4-5)	1
020566	Shield, HT2000/MAX200 W-M 200A	1
020618	Shield, HT2000/MAX200 W-M 100A	1
023866	Cable: PS/W-M Cntor (1X10)	1

### **WATER MUFFLER SYSTEM 240/480V, 3PH, 60 HZ W/O HOSES**

Stock No. - 034097

<u>Stock Number</u>	<u>Description</u>	<u>Quantity</u>
020423	Cap, MAX200 shield	1
015262	Swivel, #12 3/4 Syn hose Brs	3
015264	Ferrule, 1.150 ID x .88 Brs	3
015052	Adapter, 3/4 NPT x #12	1
015578	Reducer bushing, 2" x 3/4", galv	1
015509	Nipple 2" x CL, galv	1
027009	Filter, 2" NPT, water	1
027012	Silicone lubricant	1
028042	Water supply, W-M, MAX200 (refer to page 4-6)	1
034148	Nozzle Assy:200A W-M 90 Deg Ftg (refer to page 4-5)	1
020566	Shield, HT2000/MAX200 W-M 200A	1
020618	Shield, HT2000/MAX200 W-M 100A	1
023866	Cable: PS/W-M Cntor (1X10)	1

## STANDARD COMPONENTS

---

### **WATER MUFFLER SYSTEM 380-415V, 3PH, 50 HZ W/HOSES**

Stock No. - 034100

<u>Stock Number</u>	<u>Description</u>	<u>Quantity</u>
020423	Cap, MAX200 shield	1
024022	Hose assembly, #12 x 50 ft. with:	1
015262	Swivel, #12 3/4 Syn hose Brs (attached to hose)	2
015264	Ferrule, 1.150 ID x .88 Brs (attached to hose)	2
046020	Hose:3/4"ID Blk	50'
024023	Hose assembly, #12 x 4 ft. with:	1
015262	Swivel, #12 3/4 Syn hose Brs (attached to hose)	1
015264	Ferrule, 1.150 ID x .88 Brs (attached to hose)	1
015052	Adapter, 3/4 NPT x #12 (attached to hose)	1
027009	Filter, 2" NPT, water	1
015578	Reducer bushing, 2" x 3/4", galv	1
015509	Nipple 2" x CL, galv	1
046020	Hose:3/4"ID Blk	4'
027012	Silicone lubricant	1
028299	Water supply, W-M, MAX200 (refer to page 4-6)	1
034148	Nozzle Assy:200A W-M 90 Deg Ftg (refer to page 4-5)	1
020566	Shield, HT2000/MAX200 W-M 200A	1
020618	Shield, HT2000/MAX200 W-M 100A	1

### **WATER MUFFLER SYSTEM 380-415V, 3PH, 50 HZ W/O HOSES**

Stock No. - 034101

<u>Stock Number</u>	<u>Description</u>	<u>Quantity</u>
020423	Cap, MAX200 shield	1
015262	Swivel, #12 3/4 Syn hose Brs	3
015264	Ferrule, 1.150 ID x .88 Brs	3
015052	Adapter, 3/4 NPT x #12	1
015578	Reducer bushing, 2" x 3/4", galv	1
015509	Nipple 2" x CL, galv	1
027009	Filter, 2" NPT, water	1
027012	Silicone lubricant	1
028299	Water supply, W-M, MAX200 (refer to page 4-6)	1
034148	Nozzle Assy:200A W-M 90 Deg Ftg (refer to page 4-5)	1
020566	Shield, HT2000/MAX200 W-M 200A	1
020618	Shield, HT2000/MAX200 W-M 100A	1

## STANDARD COMPONENTS

---

### WATER MUFFLER SYSTEM 600V, 3PH, 60 HZ W/HOSES

Stock No. - 034098

<u>Stock Number</u>	<u>Description</u>	<u>Quantity</u>
020423	Cap, MAX200 shield	1
024022	Hose assembly, #12 x 50 ft. with:	1
015262	Swivel, #12 3/4 Syn hose Brs (attached to hose)	2
015264	Ferrule, 1.150 ID x .88 Brs (attached to hose)	2
046020	Hose:3/4"ID Blk	50'
024023	Hose assembly, #12 x 4 ft. with:	1
015262	Swivel, #12 3/4 Syn hose Brs (attached to hose)	1
015264	Ferrule, 1.150 ID x .88 Brs (attached to hose)	1
015052	Adapter, 3/4 NPT x #12 (attached to hose)	1
027009	Filter, 2" NPT, water	1
015578	Reducer bushing, 2" x 3/4", galv	1
015509	Nipple 2" x CL, galv	1
046020	Hose:3/4"ID Blk	4'
027012	Silicone lubricant	1
028308	Water supply, W-M, MAX200 (refer to page 4-6)	1
034148	Nozzle Assy:200A W-M 90 Deg Ftg (refer to page 4-5)	1
020566	Shield, HT2000/MAX200 W-M 200A	1
020618	Shield, HT2000/MAX200 W-M 100A	1

### WATER MUFFLER SYSTEM 600V, 3PH, 60 HZ W/O HOSES

Stock No. - 034099

<u>Stock Number</u>	<u>Description</u>	<u>Quantity</u>
020423	Cap, MAX200 shield	1
015262	Swivel, #12 3/4 Syn hose Brs	3
015264	Ferrule, 1.150 ID x .88 Brs	3
015052	Adapter, 3/4 NPT x #12	1
015578	Reducer bushing, 2" x 3/4", galv	1
015509	Nipple 2" x CL, galv	1
027009	Filter, 2" NPT, water	1
027012	Silicone lubricant	1
028308	Water supply, W-M, MAX200 (refer to page 4-6)	1
034148	Nozzle Assy:200A W-M 90 Deg Ftg (refer to page 4-5)	1
020566	Shield, HT2000/MAX200 W-M 200A	1
020618	Shield, HT2000/MAX200 W-M 100A	1

**NOZZLE ASSEMBLY, W-M, HT2000/MAX200**

Stock No. - 034148

<u>Stock Number</u>	<u>Description</u>	<u>Item</u>	<u>Quantity</u>
034102	Wrench, W-M sleeve, HT200/MAX200	1	1
034149	Sleeve: 200A W-M	2	1
044031	O-Ring: Buna 70 Duro 1.739X.070	3	2
034150	Nozzle Only :200A W-M 90 Deg Ftg	4	1
044135	O-Ring: Buna 70 Duro 1.925X.103	5	2
075439	Thumb screw:8-32 X 3/8	6	3

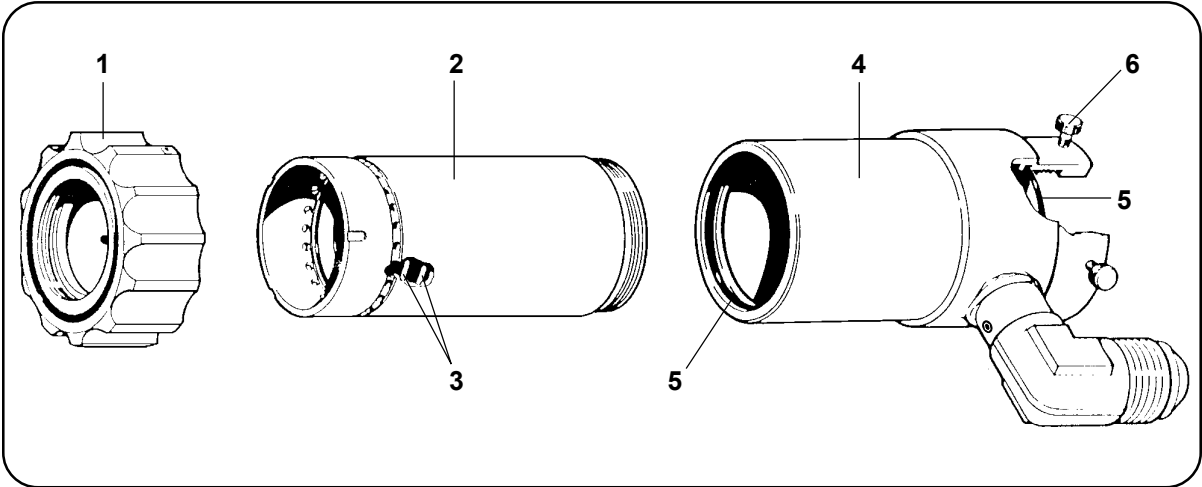

Figure 4-1 Nozzle Assembly

## STANDARD COMPONENTS

---

### WATER SUPPLY, W-M, HT2000/MAX200

Stock No. - 028042 — 240/480V, 3PH, 60 HZ

Stock No. - 028299 — 380-415V, 3PH, 50 Hz

<u>Stock Number</u>	<u>Description</u>	<u>Item</u>	<u>Quantity</u>
031006 or 031088	Pump (3/4 DL) assembly with motor, 2 HP, 3500 RPM 230-460 VAC, 3 phase	1	1
031088	Pump (3/4DL) assembly with motor, 2 HP, 3500 RPM 380-415 VAC, 3 phase	1	1
015051	Adapter, 3/4 NPT x #12	2	2
004437	Base, water supply W-M	3	1
008045	Fitting, conduit elbow, 1/2 x 1/2	4	1
008047	Strain relief, 1/2 x .250-.375	5	1
003017	Contactor, size 00,120 VAC coil;	6	1
003029	Heater:003017 Cntor 3.00A -W38		3
003170	Heater:003017 Cntor 6.06A -W40		3
034006	Contactor mounting bracket	7	1
046011	Conduit,1/2" sealtite flexible	8	6 "
008044	Fitting, conduit straight, 1/2 x 1/2	9	1

Stock No. - 028308 — 600V, 3PH, 60 Hz

<u>Stock Number</u>	<u>Description</u>	<u>Item</u>	<u>Quantity</u>
031089	Pump (3/4 DL) assembly with motor, 2 HP, 3500 RPM 575 VAC, 3 phase	1	1
015051	Adapter, 3/4 NPT x #12	2	2
004437	Base, water supply W-M	3	1
008045	Fitting, conduit elbow, 1/2 x 1/2	4	1
008047	Strain relief, 1/2 x .250-.375	5	1
003017	Contactor, size 00,120 VAC coil;	6	1
003171	Heater:003017 Cntor 2.45A -W36		3
034006	Contactor mounting bracket	7	1
046011	Conduit,1/2" sealtite flexible	8	6 "
008044	Fitting, conduit straight, 1/2 x 1/2	9	1

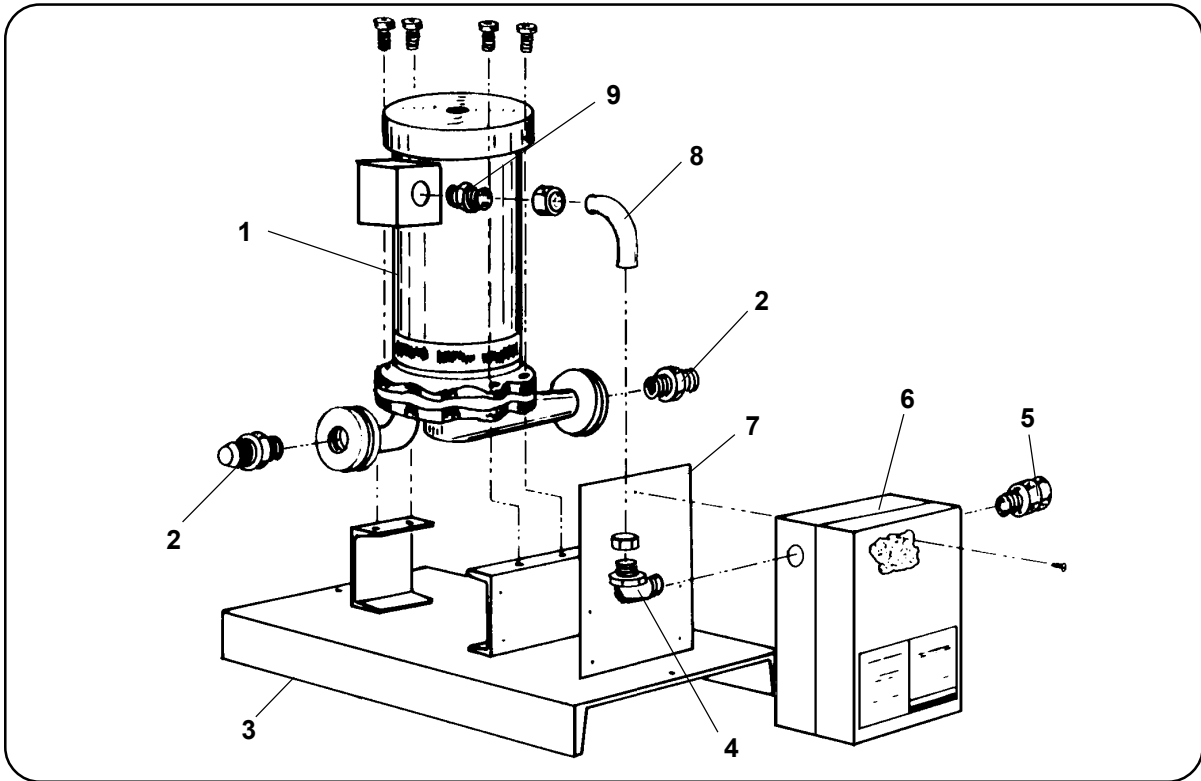

Figure 4-2 Water Supply Assembly

**WATER MUFFLER PUMP ASSEMBLY (SEE APPENDIX)**

Stock No. - 031049

<u>Stock Number</u>	<u>Description</u>	<u>Item</u>	<u>Quantity</u>
031036	Impeller, 1285505	3	1
031047	Casing, 1326505	5	1
*	Casing cap screw	5D	8
031035	Adapter cradle, 1250705	7	1
*	Adapter Cap Screws	7G	1
031048	Backhead, 1080280	22	1
031040	Clearance shim, 9157206-7-8	37	3
031041	Casing gasket, 9155333	77	1
031042	Stationary seal element, 6960440	95A	1
	Rotating seal face, 6960440	95B	1

\* Obtain locally



## STANDARD COMPONENTS

### HT2000 WATER MUFFLER PUMP CABLE

Stock Nos. - 023866 (50 ft) / 023867 (75 ft) / 023868 (100 ft)

<u>Stock Number</u>	<u>Description</u>	<u>Item</u>	<u>Quantity</u>
008195	Caclp: CPC Size 11	1	1
008205	Pin: 18-16 AWG Type III	2	3
008211	Plug Shell: CPC 11-4Rvs Sex	3	1
047190	Cord: 18-3 SV Rbr UL/CSA	4	50/75 or 100 ft

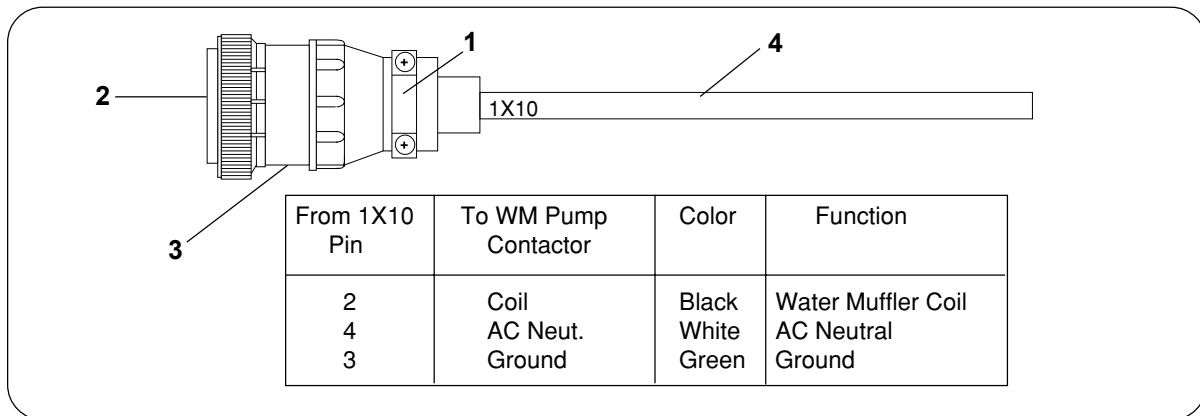

Figure 4-3 HT2000 Water Muffler Pump Cable - PS to WM

### PUMP DISCHARGE HOSE CHECK VALVE (OPTIONAL)\*

<u>Stock Number</u>	<u>Description</u>	<u>Quantity</u>
034156	Valve, check	1
015052	Gland, hose 3/4 NPT x #12 straight	2
015234	Clamp, hose 3/4 to 1-3/4 inch	2

\* Refer to Section 2, *Installation* for pump discharge hose water recovery checkout and check valve installation information.

## APPENDIX

In this section:

---

Water Muffler Pumps ..... a-2

---



# *DEAN BROTHERS PUMPS*

**INSTALLATION  
OPERATION  
AND  
MAINTENANCE  
MANUAL**

*DeanLine*  
**SERIES**

**DO NOT OPERATE PUMP BEFORE  
READING THIS MANUAL**

*ESTABLISHED 1869*  
**DEAN BROTHERS PUMPS INC.**  
*INDIANAPOLIS INDIANA, 46268*  
*P.O. Box 68172*

THE BEST IS OUR STANDARD



**MECHANICAL DESIGN SPECIFICATIONS**

Direction of Rotation ..... Clockwise (viewed from motor end).  
 Driver Rating ..... 230/460 Volt, 3 Phase, 60 Cycle, NEMA C  
 Flange, #56J Frame, Dean Standard  
 Motor, 304ss Shaft with standard shaft  
 extension for jet motor. NEMA T3B  
 temperature rating for Ex.Pr. motors. Ex.  
 Pr. motors are Class I, Group D; Class II,  
 Groups F & G.  
 @ 1750 RPM ..... ½ HP.  
 @ 3500 RPM ..... 1, 1½, and 2 HP.  
 @ RPM for Air Motor ..... 100 PSI air 4 HP @ 3000 RPM.  
 Flanges ANSI Rating ..... 125 Lb. Cast Iron (Deanalloy 20); 150 Lb.  
 316 ss (Deanalloy 50).  
 Impeller ..... Mechanically and Electronically  
 Balanced.  
 Maximum Working Pressure ..... 100 PSIG.  
 Maximum Suction Pressure ..... Any part of Working Pressure.  
 Hydrostatic Test Pressure ..... 150 PSIG Cast Iron (Deanalloy 20); 200  
 PSIG 316ss (Deanalloy 50).  
 Pumping Temperature  
 Minimum ..... Minus 20°F Cast Iron (Deanalloy 20) and  
 316ss (Deanalloy 50).  
 Maximum ..... 220°F Cast Iron (Deanalloy 20) and  
 316ss (Deanalloy 50).  
 Stuffing Box ..... Integral Mechanical Seal only, internal  
 seal face flushing all pumps.

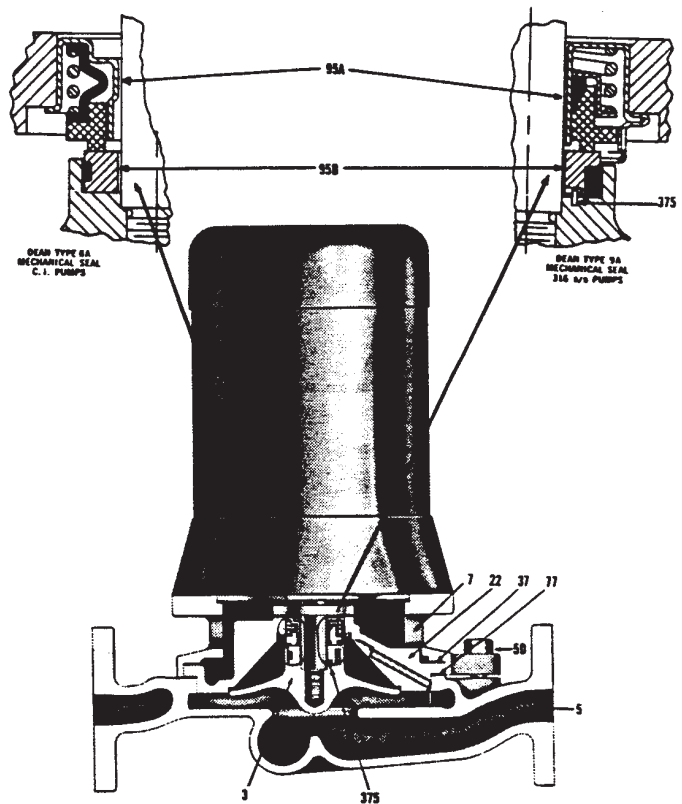

**STANDARD MATERIALS OF CONSTRUCTION**

PART NO.	PART NAME	CLASS 20	CLASS 50
3	Impeller	C.I.	316ss
5	Casing	C.I.	316ss
5D	Casing Cap Screw	1020 Stl.	302ss
7	Adapter Cradle	C.I.	C.I.
7G	Adapter Cap Screws	1020 Stl.	1020 Stl.
22	Backhead	C.I.	316ss
37	Clearance Shim	Plastic	Plastic
77	Casing Gasket	Asbestos	Asbestos
95A	Stationary Seal Element Stationary Face Spring Holder Shaft Packing	Carbon 304ss Viton	Carbon 316ss 316ss Teflon
95B	Rotating Seal Face	Ceramic	Ceramic
375	Seal Dowel Pin	Not Required	316ss

**MECHANICAL SEAL SPECIFICATIONS**

PUMP MAT'L	MECHANICAL SEAL	SUCTION PRESSURE		TEMPERATURE	
CLASS		MAX.	MIN.	MAX.	MIN.
20 or 50	Dean Type 6A, 6C or 9A	100 PSIG	2 PSIA	220°F	-20°F

**AIR MOTOR OPTION**

For best performance and life of the air motor, we offer the following suggestions and accessories.

- The exhaust silencer provided at no charge with the pump can impose sufficient back pressure so as to require as much as twenty psi additional inlet pressure. To eliminate this back pressure, we offer a muffler.
- The speed of the motor is limited by the motor manufacturer to 3,000 RPM. Since the motor is generously sized, excess inlet pressure will cause it to overspeed. To limit the top speed and allow for full range control, a regulator and gauge are available.
- For intermittent duty, frequent generous oilings at the two oiling ports are recommended. For more continuous operation, the automatic air line lubricator is recommended.
- Air motor life is further enhanced by use of the filter.

**Accessories**

- Silencer
- Pressure Regulator
- Line Lubricator
- Line Filter

**Connections**

In	Out
¼" Male	¾" Male
½" Female	½" Female
½" Female	½" Female
½" Female	½" Female

**CAUSTIC SERVICE OPTION**

6C caustic seal is offered for Caustic Service: a 304s/s seal with high alumina ceramic vs carbon faces viton bellows.

Experience in the field has indicated the wisdom of establishing a limit to caustic soda (sodium hydroxide) liquid concentrations to 30% caustic in water and 175°F temperature.

Higher concentrations exhibit two related effects which have led to seal failures. First, crystallized solids in the pumpage immobilize the seal and leakage gets progressively worse although seal faces may appear undamaged. Secondly, the crystallization of leakage through the seal stops the seal from compensating for wear. The net effect in both cases is early seal failure.

If it is possible to flush the seal chamber with water, extended seal life is possible at higher caustic concentrations. This requires the addition of the flush hole in the pump backhead.

An external water source of sufficient pressure is necessary for the flush, warm water being more effective than cold water. The flush rate should be in the order of ½ gpm. The standard caustic seal should be used.

## PRODUCT INSPECTION AND TEST

The Products of Dean Brothers Pumps Inc. are subject to thorough and rigorous quality control and inspection procedures throughout the whole of the manufacturing process to

assure proper operation in full conformity with established performance standards.

## DEAN BROTHERS PRODUCT WARRANTY

We warrant to the purchaser from us of Dean Brothers products and parts of our own manufacture that such products and parts are free under rated use and service from defects in design, material and workmanship for a period of one (1) year from the date of installation, but not to exceed eighteen (18) months from the date of shipment by us. This warranty does not cover (I) any loss or damage resulting from wear, corrosion, abrasion or deterioration due to normal use in rated service; (II) replacement of service items such as shaft packings and mechanical seals; (III) products or parts manufactured by others but furnished by us which, if defective, shall be repaired or replaced only to the extent of the original manufacturer's warranty; or (IV) any loss or damages to or defects in any such products or parts resulting from the misuse or improper storage, installation or operation thereof.

We shall not be liable, directly or indirectly, under any circumstances for consequential or incidental damages, includ-

ing, but not limited, to: (I) any loss of business or profits; and (II) labor, material or other charges, claims, losses or damages incurred or suffered from, in connection with or in consequence of the working upon, alteration, or repair of any such defective products or parts by persons or firms other than us. Our liability for breach of warranty hereunder is limited solely to the repair in our factory or to the replacement F.O.B. our factory, as the case may be, of any products or parts which shall have been determined by us, after notice to us and inspection by us within the warranty period, to be so defective when shipped by us.

THIS WARRANTY AND THE LIABILITY SET FORTH HEREIN ARE EXCLUSIVE AND IN LIEU OF ALL OTHER LIABILITIES AND WARRANTIES, EXPRESS OR IMPLIED, INCLUDING IMPLIED WARRANTIES OF MERCHANTABILITY AND FITNESS FOR PARTICULAR PURPOSE.

## WARNING

Proper storage while not in use and proper installation and startup are essential for successful pump operation. Misuse or improper storage, installation or operation of pumps may result in serious loss or damage. Dean Brothers Pumps Inc. is not responsible for any loss or damage resulting from causes beyond its control, and is not liable for charges for work performed or materials furnished to repair such loss or damage.

### RECEIVING PUMP

When the pump is received from the transportation company, it should be promptly inspected for damage and such damage noted on the bill of lading before it is signed. Claims for shipping damage must be filed against the carrier.

Care should be exercised in unloading and handling the pump.

## SPARE PARTS

To avoid prolonged down time and facilitate rapid repair of damaged pump parts, Dean Brothers recommends that the pump user maintain a minimum stock of spare parts. If the pump service is critical or the pump parts are of special materials, a spare parts stock is even more important to the user. Such a spares inventory may extend from a spare mechanical seal or seal parts through complete backhead-impeller-motor assembly. Consult your Dean Brothers representative who will assist you in selecting your spares stock.

### ORDERING SPARE PARTS

Spare parts orders will be handled with a minimum delay if the

following information is furnished by the customer with the order:

- 1) Give the pump number. This may be found on the pump name plate.
- 2) Give the part name, part number, and material of part. These should agree with the standard parts list nomenclature.
- 3) Give the quantity of each part required.
- 4) Give complete shipping instructions.

## INSTALLATION AND MAINTENANCE

### INSTALLATION

The DL Pump can be installed in any position. The pump is furnished with 150#FF suction and discharge flanges cast in-line, maintaining simplified piping layouts. Suction lines should be short and straight to avoid excessive frictional losses. If larger piping is used on the suction side of the pump an eccentric reducer or means of venting the suction line should be provided to avoid the trapping of air or vapor. A centrifugal pump should be started with the suction valve open and the discharge valve either closed or opened a slight amount.

The pump stuffing box is arranged for mechanical seals only and no packing gland is required. Seals are installed at the factory and require no attention on installation or start-up of the pump.

### OPERATION

DL pump motors are furnished with prelubricated ball bearings. No lubrication is required at startup. When bearing replacement becomes necessary, install prelubricated, permanently sealed ball bearings.

### STARTING THE PUMP

1) A centrifugal pump should be started with the suction valve open and the discharge valve either closed or opened a slight amount.

2) When the source of liquid supplied to the pump is below atmospheric pressure or located below the pump, the pump must be primed prior to start up.

*A centrifugal pump should never be run without liquid in the casing. Extensive damage may result, particularly to the mechanical seal.*

3) Check all piping connections, making certain that connections are to the correct openings and that all connections are tight.

4) Check the electrical connections.

5) It is most important to check the direction of rotation of the pump before allowing the pump to come up to speed. To check rotation direction, push the starting button and instantly push the stop button. This will allow the motor to turn over a few revolutions and the direction of rotation to be observed. A direction of rotation arrow is shown on the side of the pump casing. If rotation direction is incorrect, change the wiring connections and recheck rotation. *Operating the pump in reverse rotation may cause extensive damage.*

6) After the pump is up to speed the discharge valve may be opened slowly. A centrifugal pump should not be operated for any appreciable time against a closed discharge valve since the liquid in the casing will begin to heat up.

### SERVICING

The pump may be serviced easily and quickly. It is not necessary to disconnect the piping or remove the pump casing from the line. The entire motor-adapter cradle-backhead-impeller

assembly is removed from the casing and may be taken to a convenient location for further servicing.

### DISASSEMBLY PROCEDURE

- a.) Always disconnect motor electrical leads.
- b.) Isolate pump casing to prevent spillage by closing suction and discharge valves.
- c.) Remove casing cover bolts Part # 5D.
- d.) Lift out pump and motor leaving casing in the line.
- e.) To remove impeller Part 3, place wrench on impeller nut and a large screw driver in slot provided in motor end of shaft to hold shaft when backing off impeller. Impeller turns off counter clockwise.
- f.) Backhead Part # 22 will slip free of adapter cradle Part # 7.
- g.) If motor is to be replaced, continue to dismantle Part # 7 from motor.
- h.) If seals are to be replaced, press out stationary unit Part # 95A from backhead Part # 22 and remove rotating seal face Part # 95B from impeller Part # 3.
- i.) Remove casing gasket Part # 77. Put in new gasket on reassembly.

### REASSEMBLY PROCEDURE

A new set of clearance shims together with a new casing gasket should be on hand to use as needed in the reassembly. Reassembly is a reverse of the above procedure. Whether using old or new parts, be sure that no foreign material, dirt, or grime is left on the parts. Before installing unit back into casing, put in new casing gasket Part #77.

Special care should be used in handling the mechanical seal. It should be kept clean at all times.

When all original pump parts are used, exclusive of mechanical seals, the shims Part # 37, which allow for proper impeller clearance, may be reused and are placed between the backhead Part #22 and adapter cradle Part # 7. If any new pump parts and/or new motors are used, other than the mechanical seal, be sure to order or have on hand new shims Part # 37 so that the following steps can be taken:

- 1) Remove all old shims Part # 37.
- 2) Slip backhead Part # 22 into adapter cradle Part # 7 and screw impeller Part # 3 onto motor shaft.
- 3) Measure the clearance with feeler gauge between the impeller Part # 3 and the backhead Part # 22. Be sure that backhead is tight to adapter cradle Part # 7 when taking the measurement.
- 4) Subtract .010" from your measurement of the impeller to backhead clearance and the resultant is the proper thickness of shim Part # 37 required to assure proper clearance for top pump performance.
- 5) Remove impeller and backhead and, installing the new shim, proceed with reassembly, reversing procedure (a) through (h). Pull down evenly on casing cap screws Part # 5D to about 125 pound-inches torque.

# DeanLine Pumps

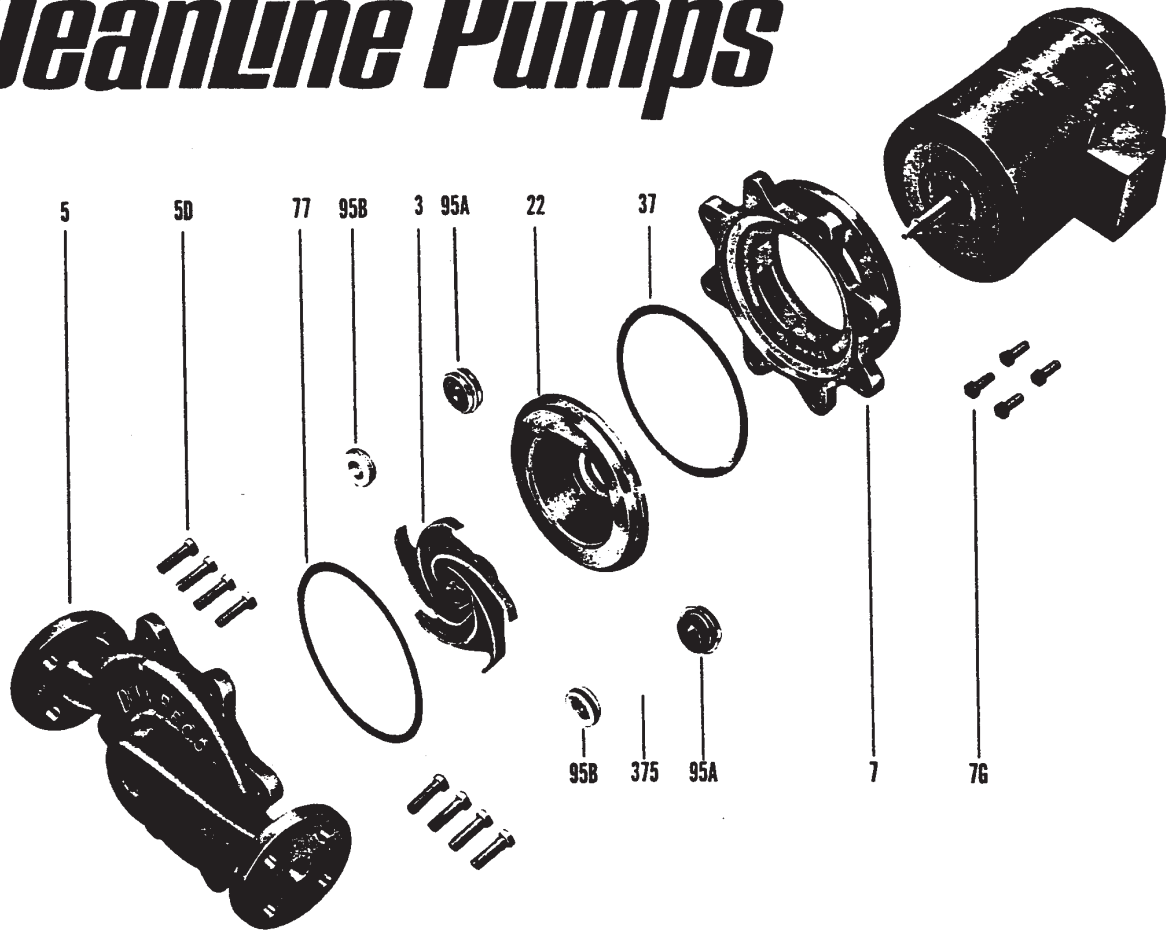

Part	Part No.	Deanalloy Class 20	Deanalloy Class 50
Impeller	3	C.I.	316ss
Casing	5	C.I.	316ss
Casing Cap Screw	5D	1020 Stl.	302ss
Adapter Cradle	7	C.I.	C.I.
Adapter Cap Screws	7G	1020 Stl.	1020 Stl.
Backhead	22	C.I.	316ss
Clearance Shim	37	Plastic	Plastic
Casing Gasket	77	Asbestos	Asbestos
Stationary Seal Element	95A	Carbon	Carbon
Stationary Face		304ss	316ss
Spring		Viton	316ss
Holder			Teflon
Shaft Packing			
Rotating Seal Face	95B	Ceramic	Ceramic
Seal Dowel Pin	375	Not Required	316ss

*\*For caustic service, use Dean Type 6C Seal with High Alumina Ceramic*