

* THESE ITEMS ARE REQUIRED WHEN A RHF IS USED
 * WHEN A LHF IS USED SHIELDED TORCH LEADS CONNECT DIRECTLY TO POWER SUPPLY

ELECTRICAL SCHEMATIC: HSD130A POWER SUPPLY
 013363
 SHEET 1 OF 15

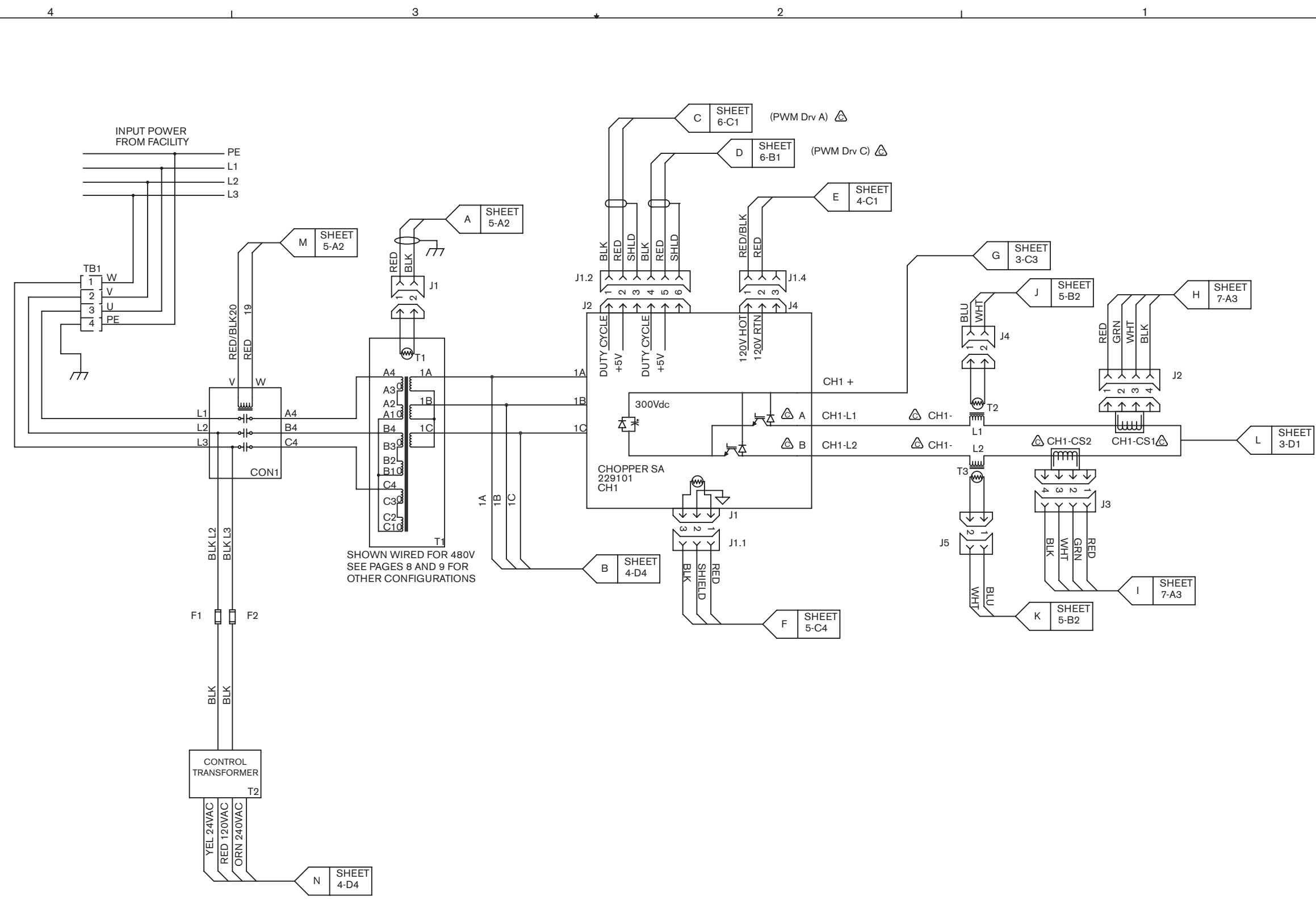

ELECTRICAL SCHEMATIC: HSD130A POWER SUPPLY
 013363
 SHEET 2 OF 15



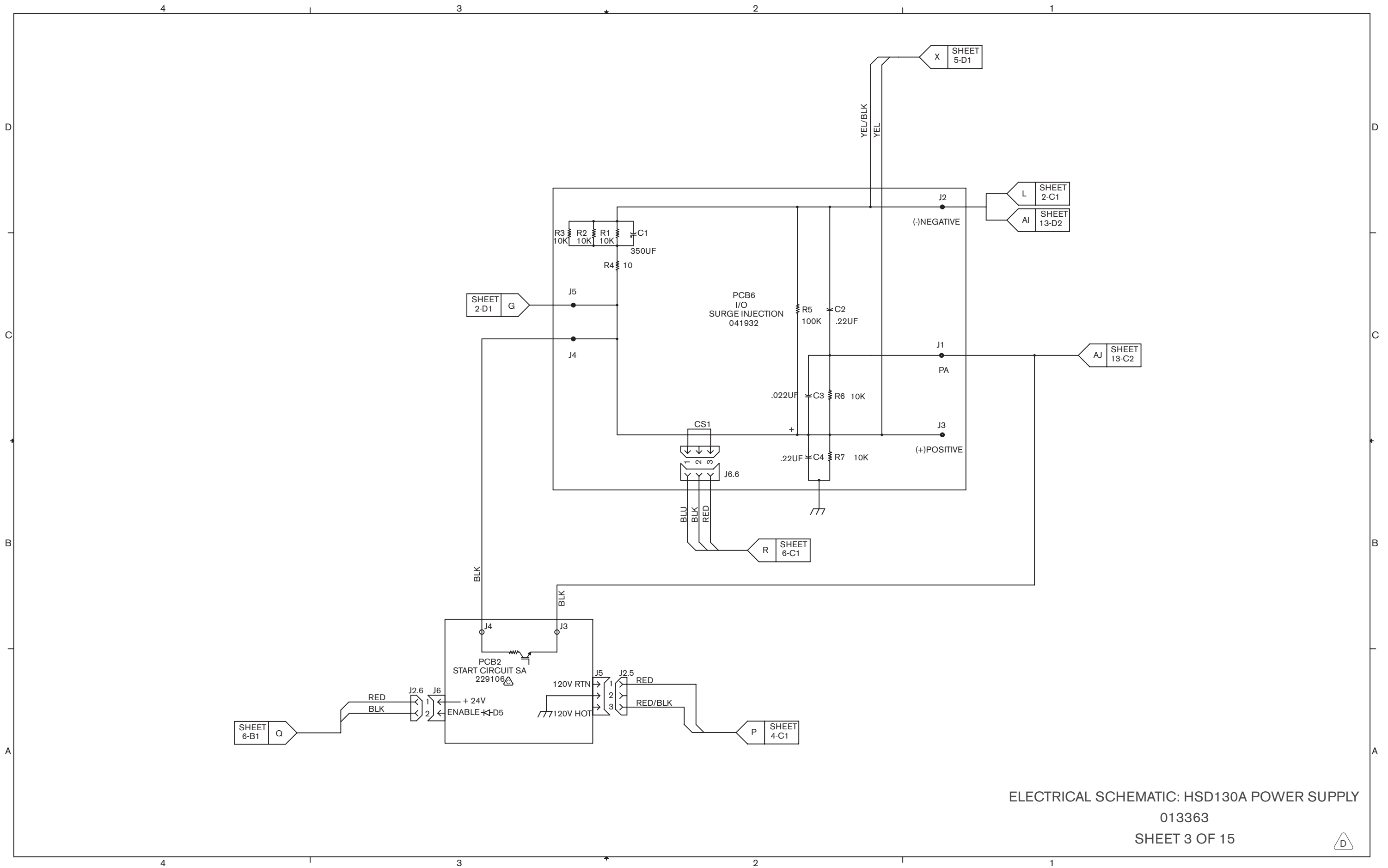

ELECTRICAL SCHEMATIC: HSD130A POWER SUPPLY
 013363
 SHEET 3 OF 15



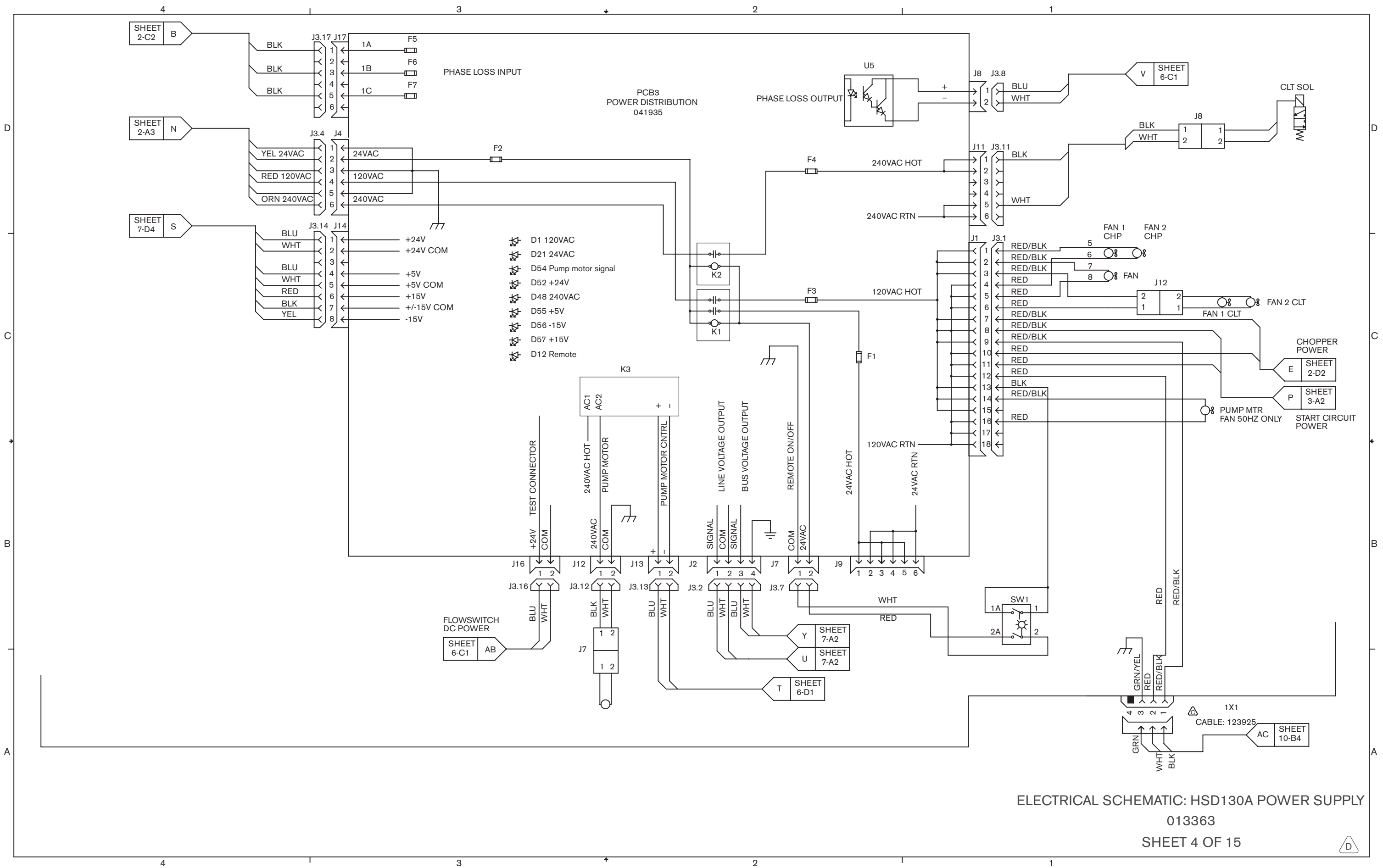

ELECTRICAL SCHEMATIC: HSD130A POWER SUPPLY
 013363
 SHEET 4 OF 15

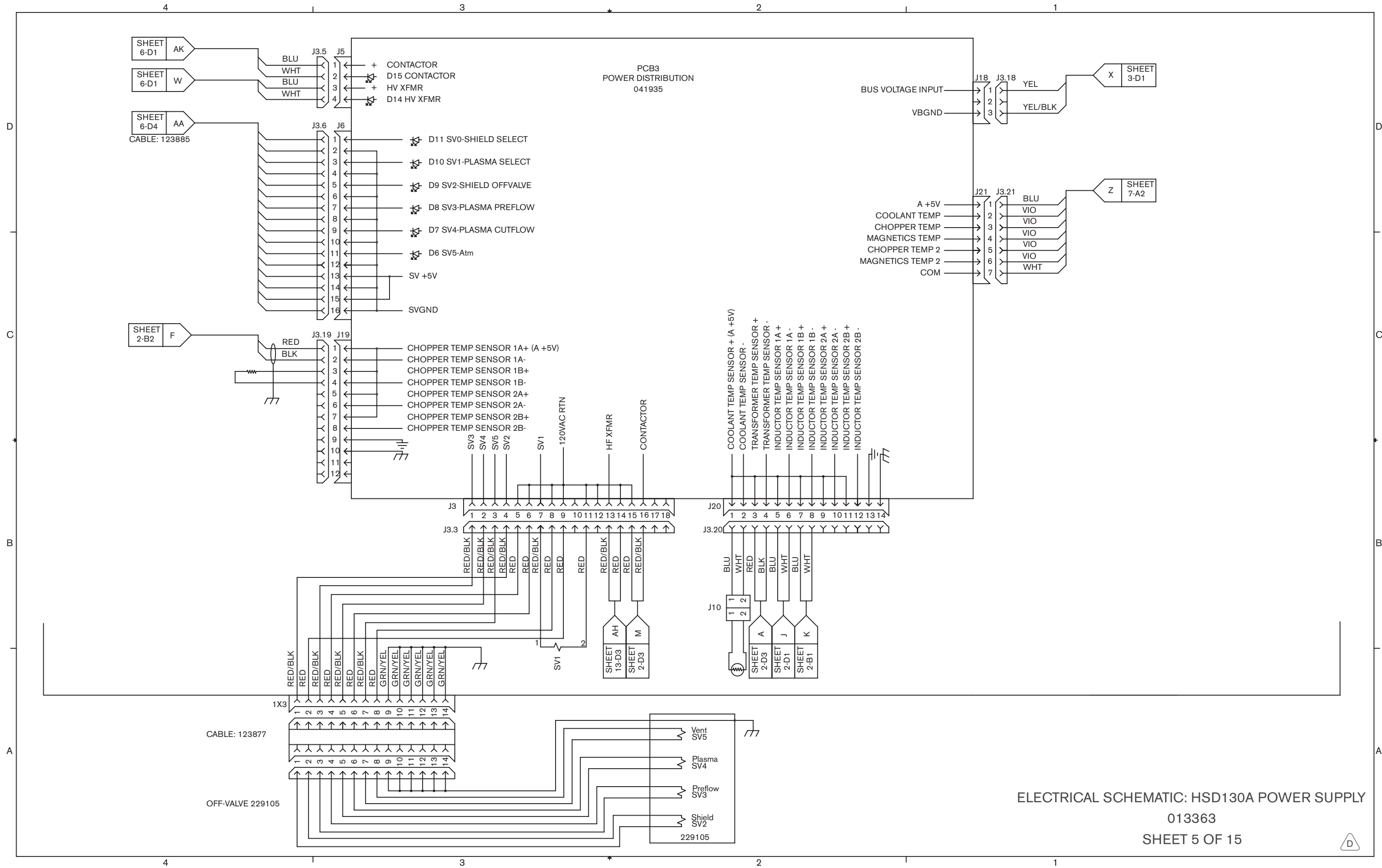

**ELECTRICAL SCHEMATIC: HSD130A POWER SUPPLY
013363
SHEET 5 OF 15**

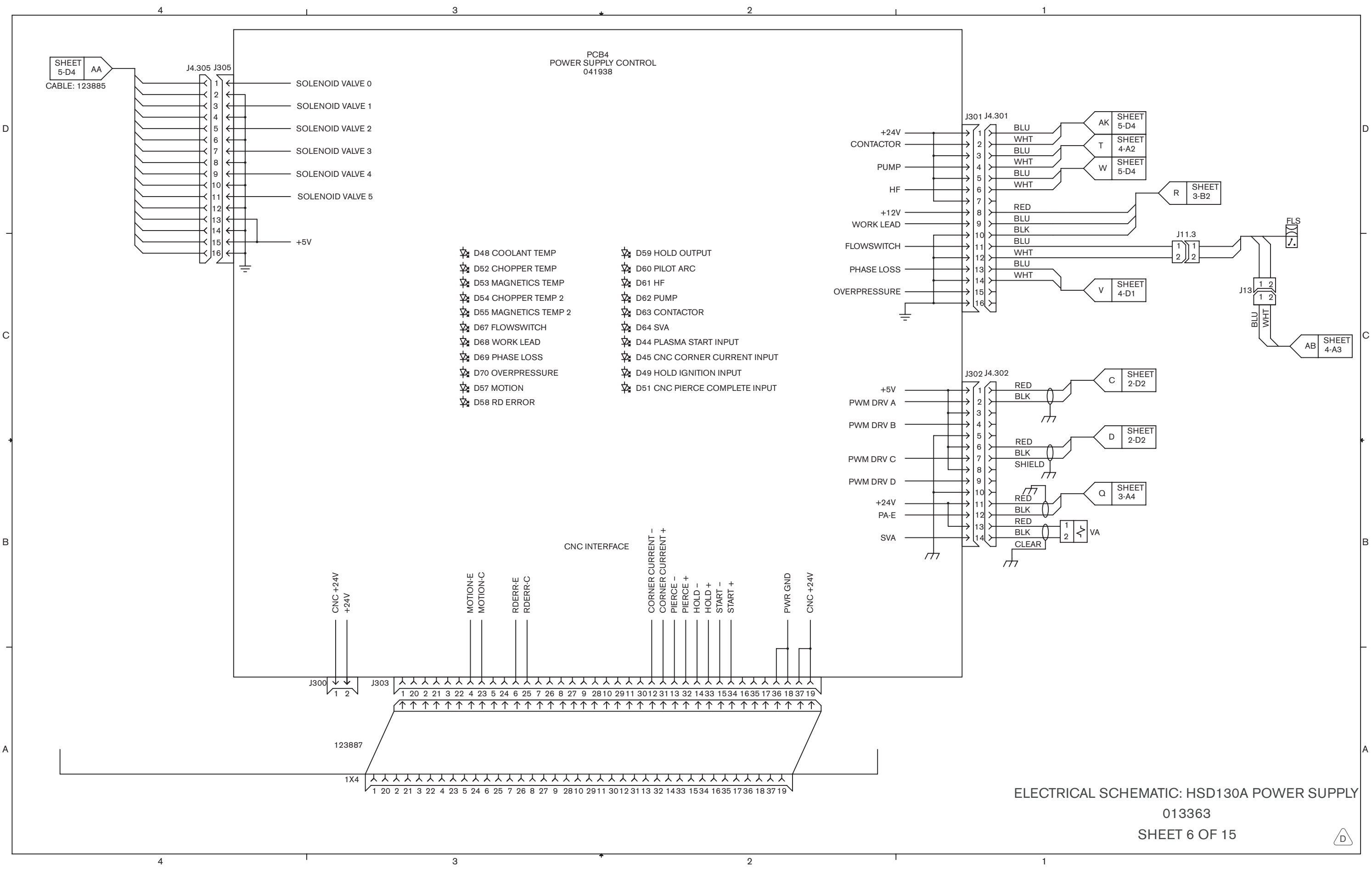

ELECTRICAL SCHEMATIC: HSD130A POWER SUPPLY
 013363
 SHEET 6 OF 15

PCB4
POWER SUPPLY CONTROL
041938

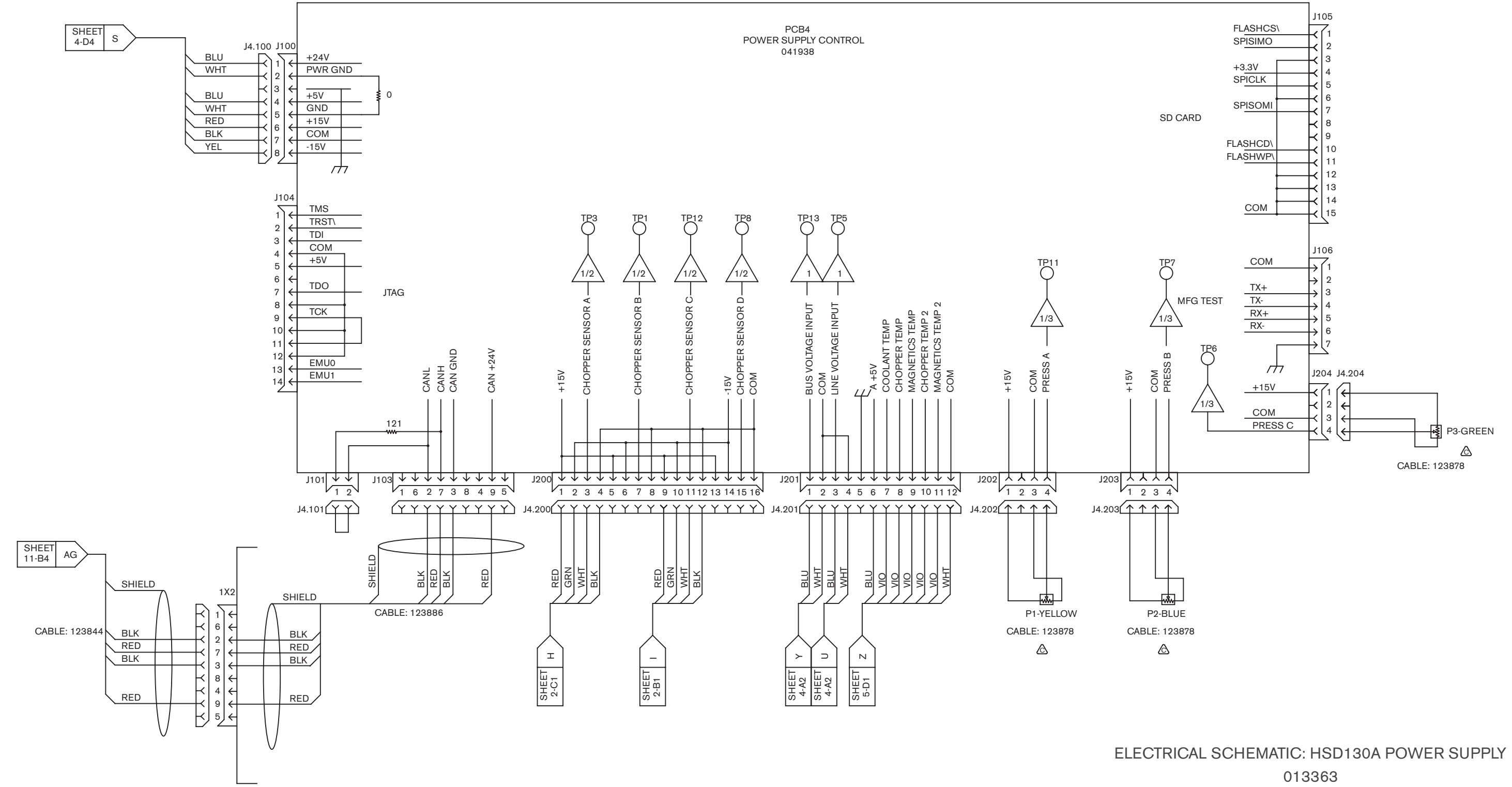

ELECTRICAL SCHEMATIC: HSD130A POWER SUPPLY
013363
SHEET 7 OF 15

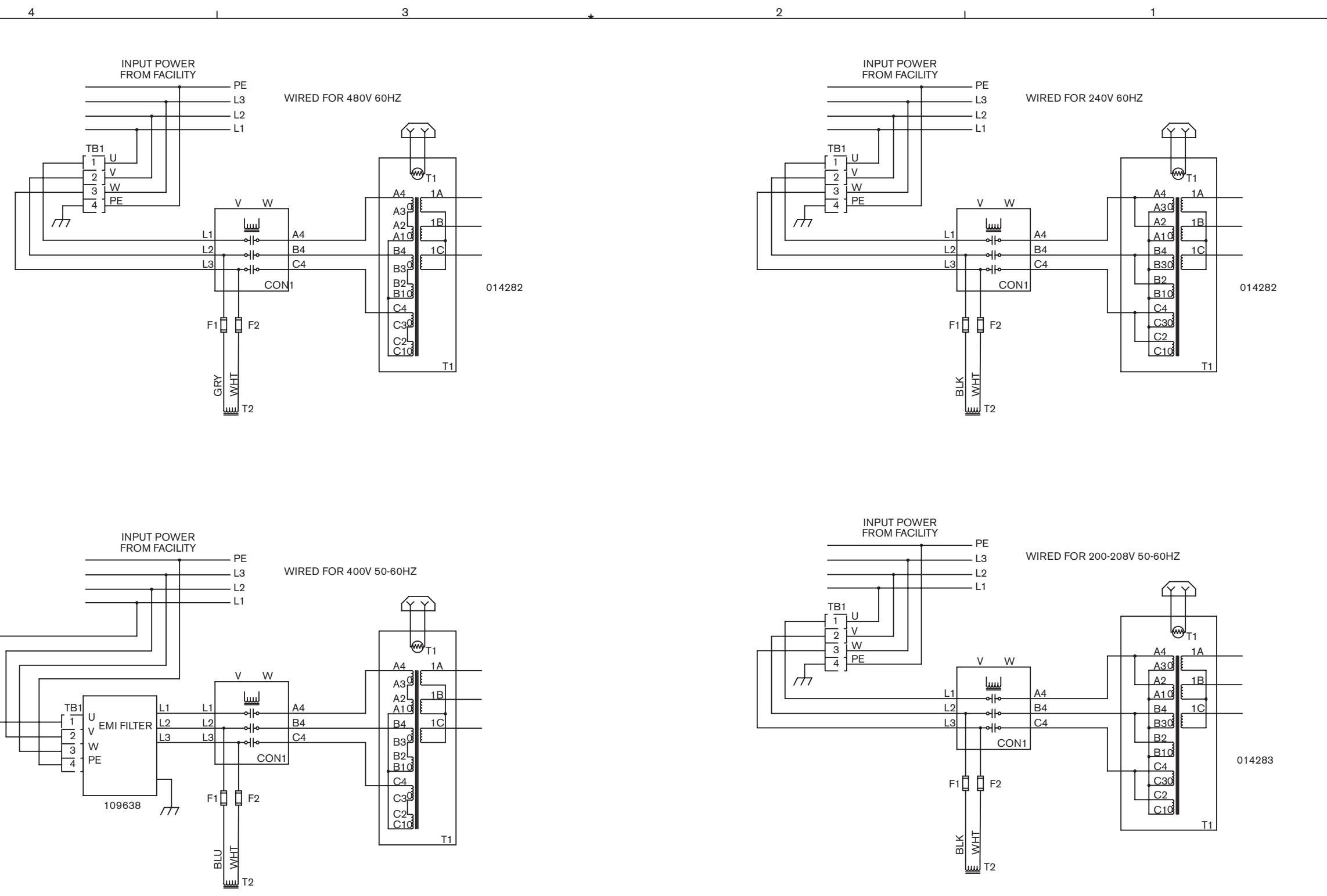

ELECTRICAL SCHEMATIC: HSD130A POWER SUPPLY
 013363
 SHEET 8 OF 15



4

3

2

1

D

D

C

C

B

B

A

A

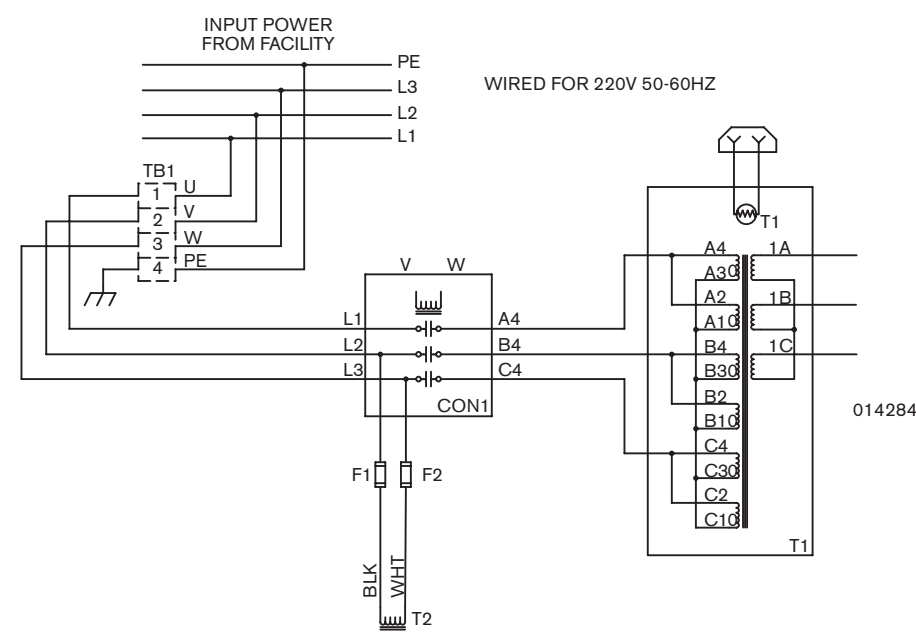

014284

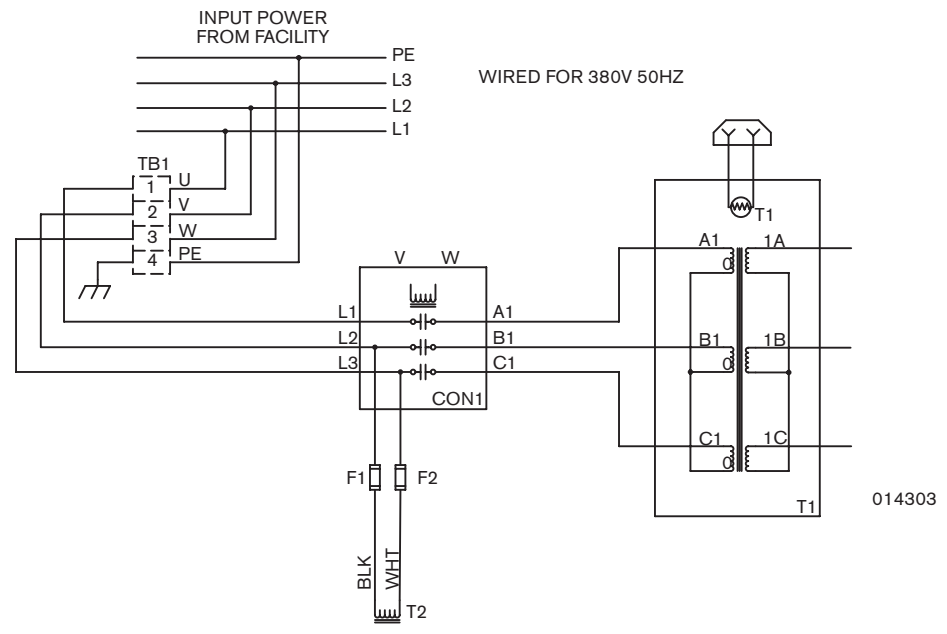

014303

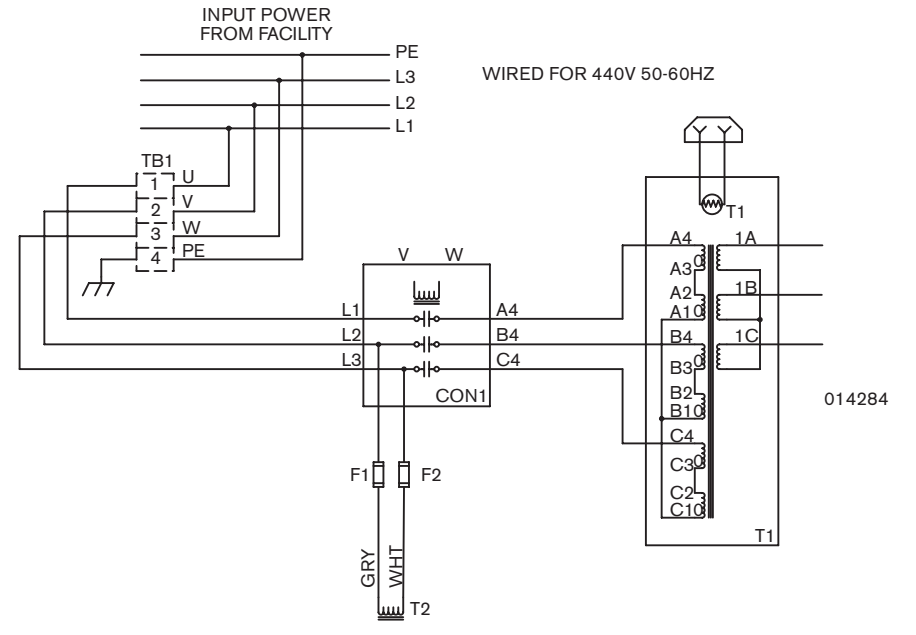

014284

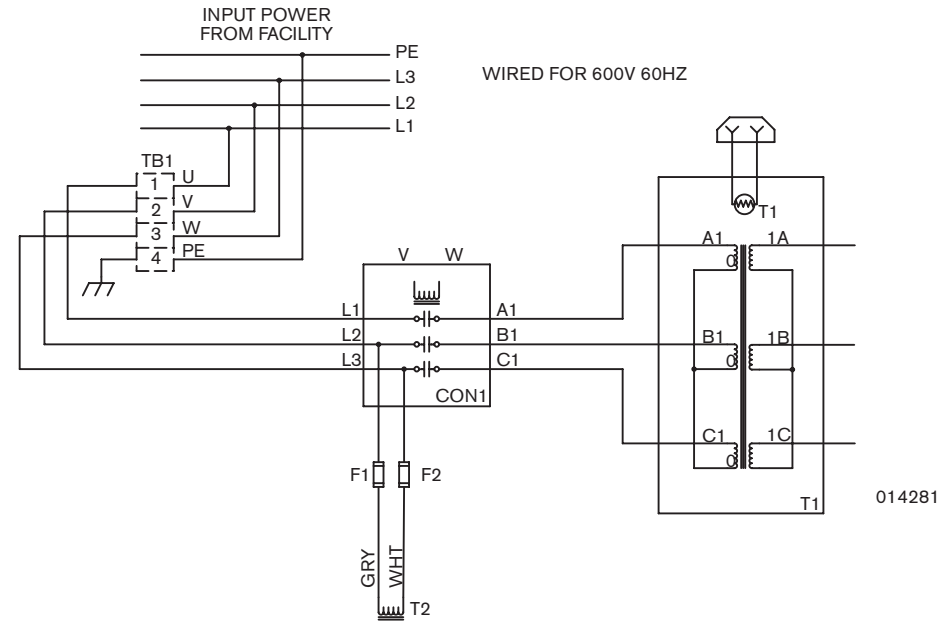

014281

ELECTRICAL SCHEMATIC: HSD130A POWER SUPPLY

013363

SHEET 9 OF 15



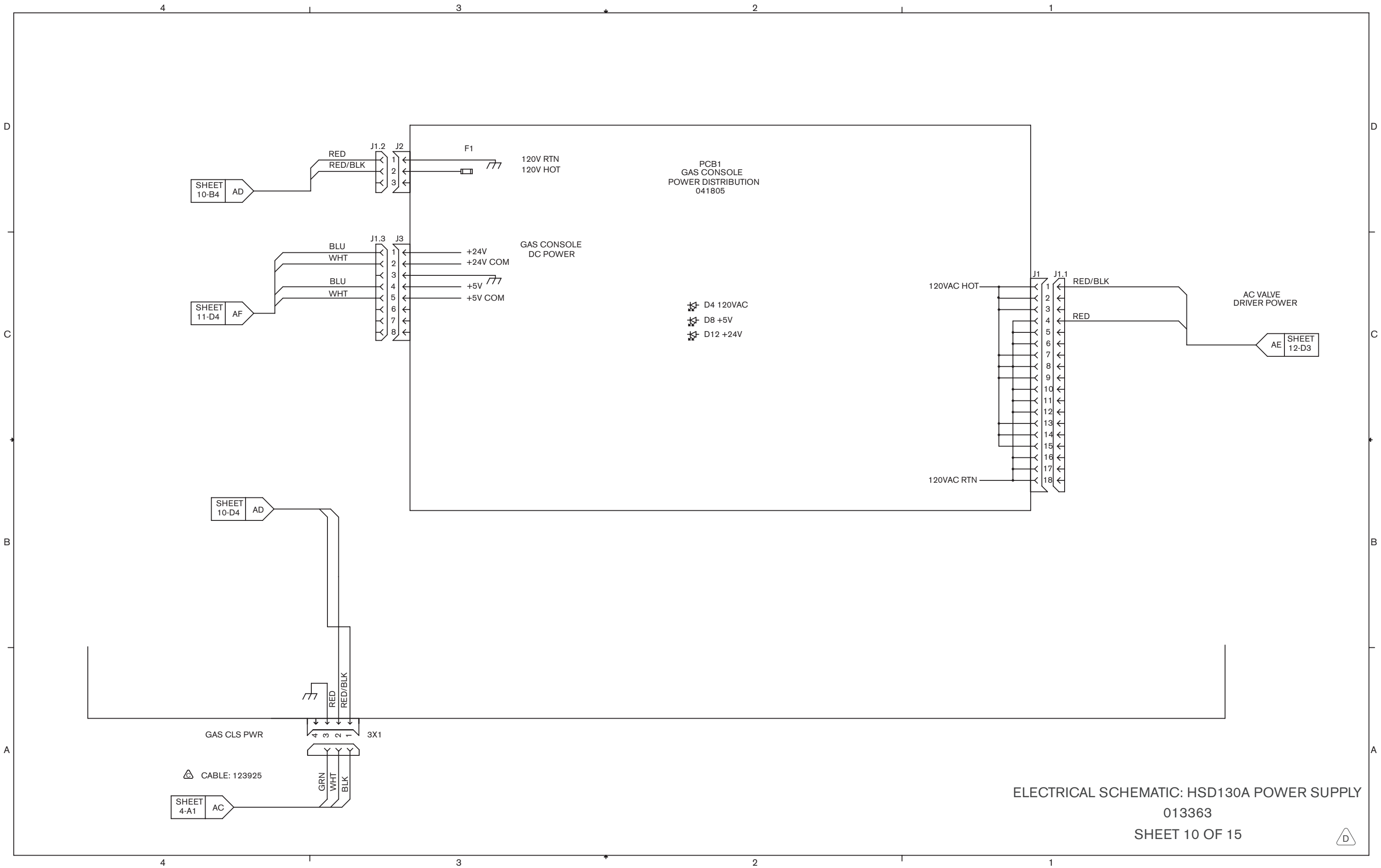

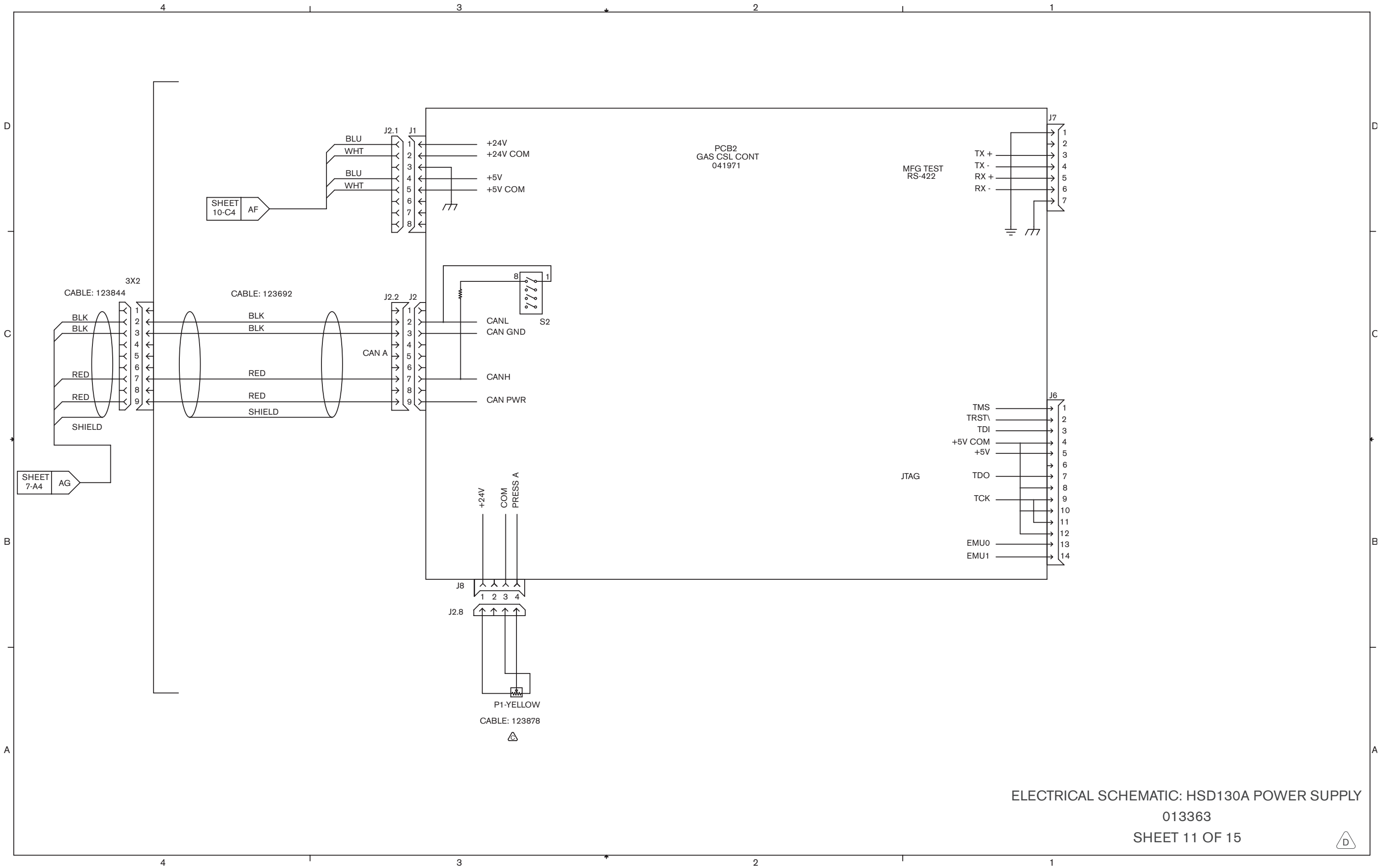

ELECTRICAL SCHEMATIC: HSD130A POWER SUPPLY
 013363
 SHEET 11 OF 15



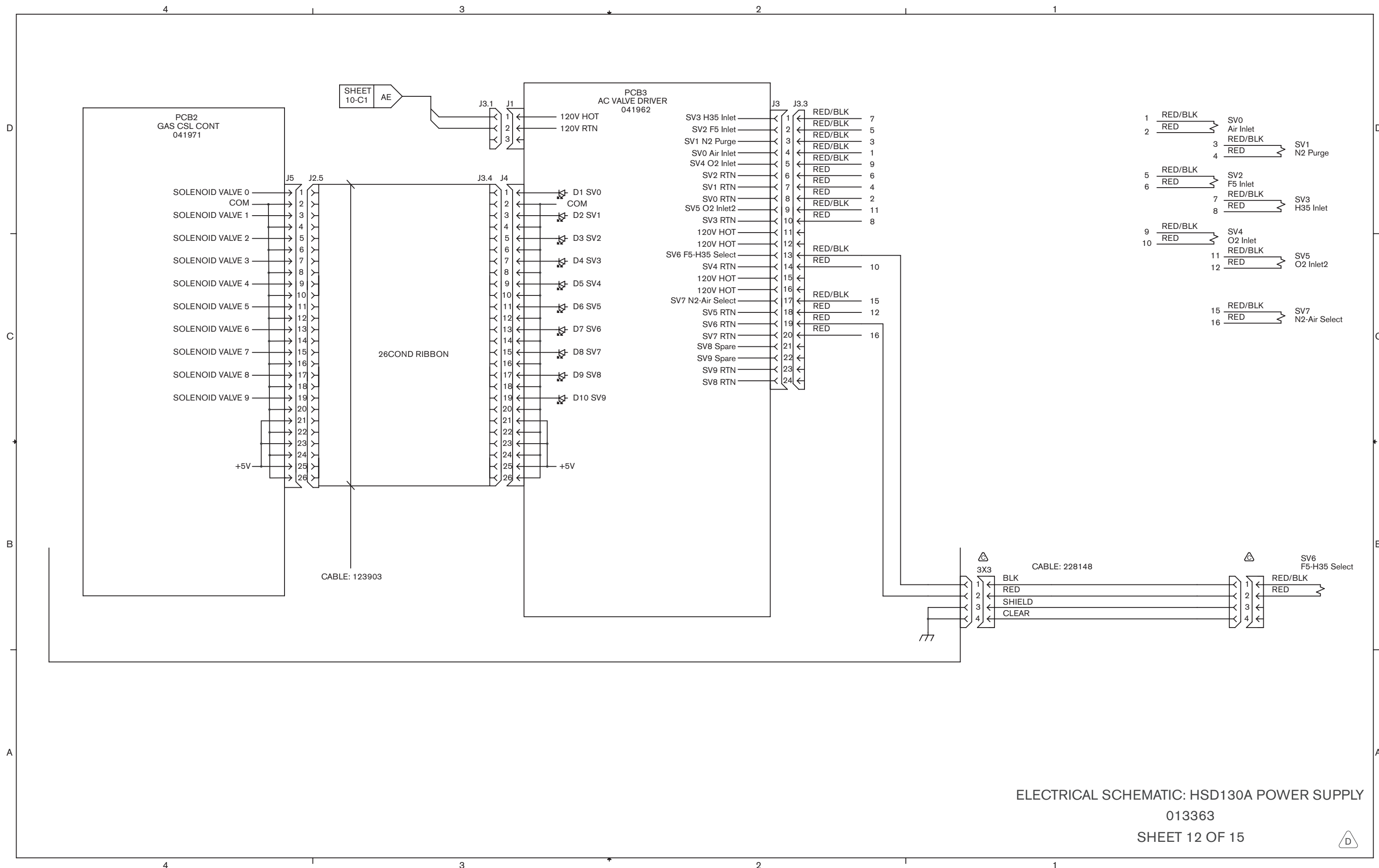

ELECTRICAL SCHEMATIC: HSD130A POWER SUPPLY
 013363
 SHEET 12 OF 15

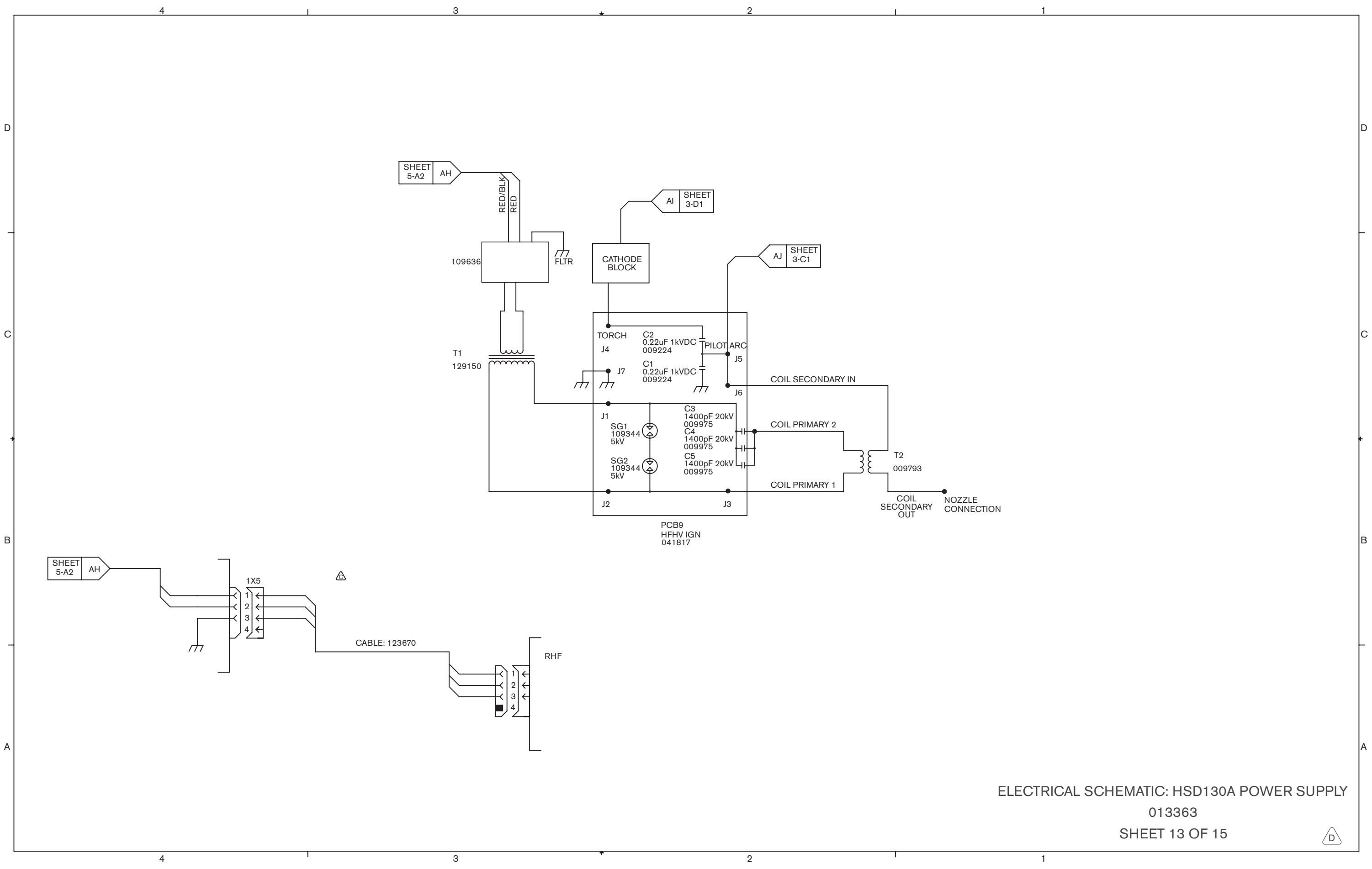

ELECTRICAL SCHEMATIC: HSD130A POWER SUPPLY
 013363
 SHEET 13 OF 15



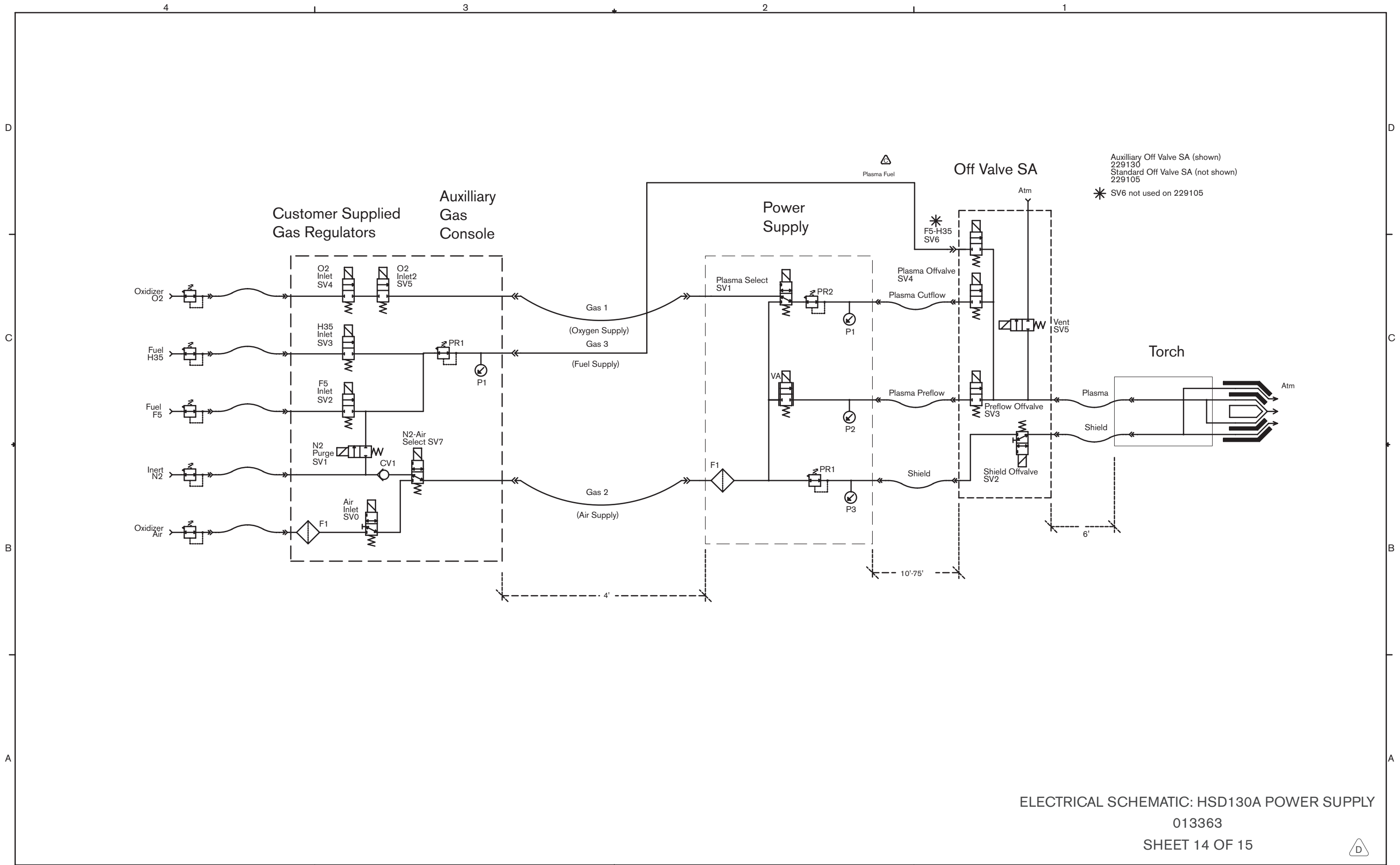

ELECTRICAL SCHEMATIC: HSD130A POWER SUPPLY
 013363
 SHEET 14 OF 15



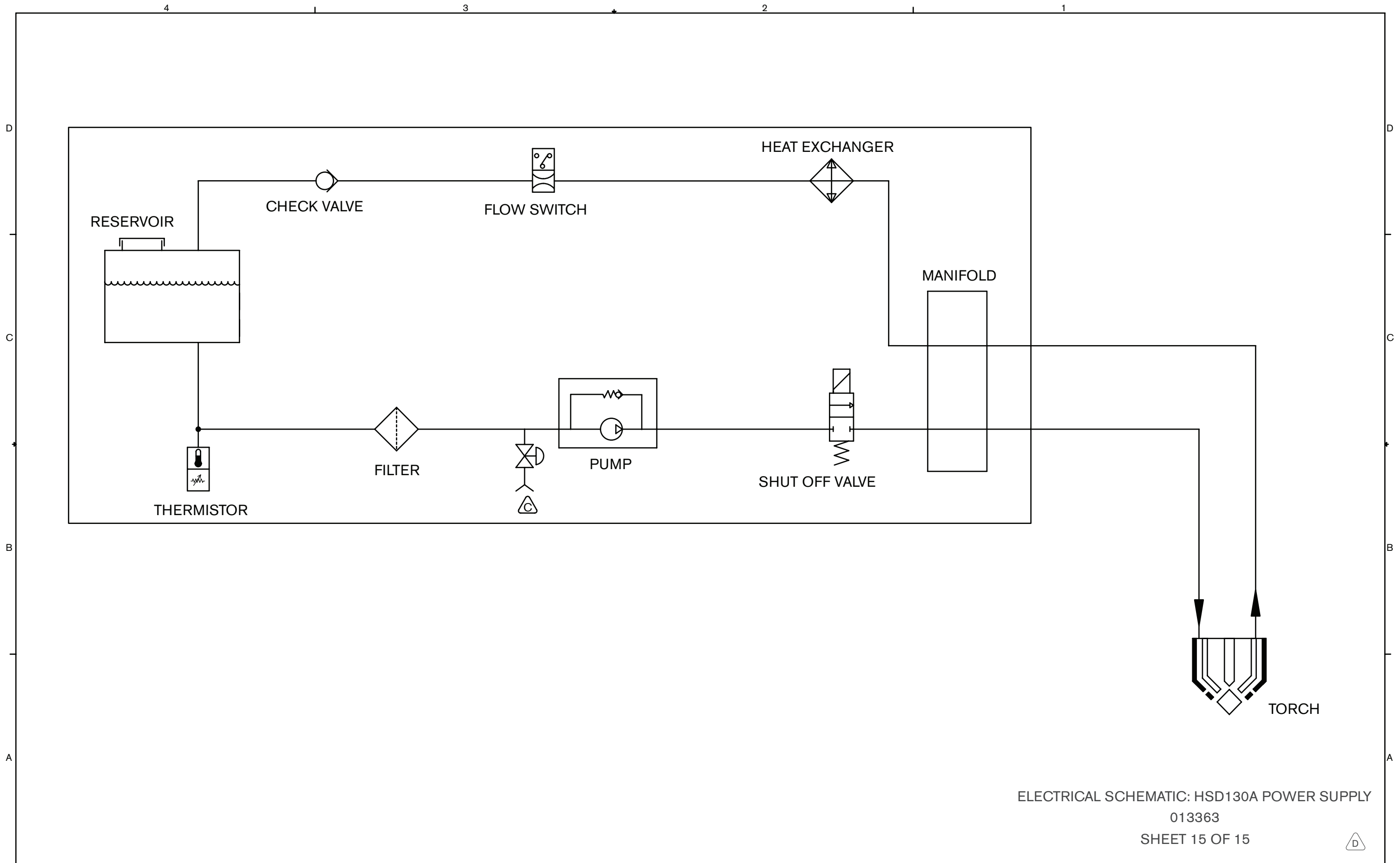

ELECTRICAL SCHEMATIC: HSD130A POWER SUPPLY
 013363
 SHEET 15 OF 15

