

# True Bevel™ technology – HPRXD® bevel compensation cut charts

White paper

## Introduction

---

Using plasma systems to perform bevel cutting on specially designed cutting tables (with bevel heads) has been done in the metal cutting industry for years. Many parts that are cut on plasma cutting tables are ultimately beveled in subsequent secondary operations, most often for weld preparation. By using a bevel head, you can eliminate secondary operations and increase productivity.

However, one large obstacle to realizing this gain is that the plasma arc changes its physical behavior as you tilt the torch. Cutting parts that meet the desired size and bevel angles requires compensation adjustments to angle and kerf. The process of determining these compensation values is time-intensive, consumes a large amount of material, and is a very iterative process. Many operators have found this process to be a significant impediment to maintaining productivity on their bevel cutting table and some have even given up trying, letting their expensive, automated bevel equipment sit idle.

With True Bevel™ technology, Hypertherm Associates provides you with flexible and adjustable bevel process parameter tables, or compensation tables. These tables provide you with compensation values that produce a better first attempt and should require only small adjustments. You can use the True Bevel technology process parameter tables for AC-type bevel heads (tilt-rotate) and with ABXYZ-type bevel heads (tilt-tilt with XYZ compensation), which produce a virtual pivot point.

**Note:** This paper assumes that you have validated the bevel head motion and mechanics (and associated transformation equations) before attempting to use the compensation tables. Materials used for the development of this white paper were based on U.S. customary units (inches). Metric conversions are provided for reference.

## Minimum requirements for True Bevel technology process parameter tables

---

The following requirements must be met in order to use the True Bevel technology process parameter tables supplied by Hypertherm Associates:

### All users:

- HPRXD® plasma system (HPR130XD, HPR260XD, HPR400XD, or HPR800XD)
- Computer numerically controlled cutting table with an AC-type bevel head (tilt-rotate) or an ABXYZ-type bevel head (tilt-tilt with a virtual bevel pivot point via XYZ compensation) with associated, validated transformation equations
- Microsoft® Excel® 2003, 2007, or 2010
- Microsoft Windows XP® or Windows 7® operating system

### Additional requirements for HPRXD-only users:

- All the previously listed requirements that apply to all users, plus:
  - Computer Numeric Controller (CNC)
  - Computer Aided Manufacturing (CAM) software to read outputs from the True Bevel technology process parameter tables and output the part program code

### Additional requirements only for users of Hypertherm Associates SureCut™ technology:

- All the previously listed requirements that apply to all users, plus:
  - EDGE® Pro with Phoenix® 9.70 or later
  - ProNest® 10.1 or later

## Bevel cut type definition

---

Three types of bevel cuts are covered in Hypertherm Associates' True Bevel technology process parameter data tables: V cuts, A cuts, and Y Top cuts. While other bevel profiles exist, they are not included in the current True Bevel technology process parameter tables. For reference, I cuts

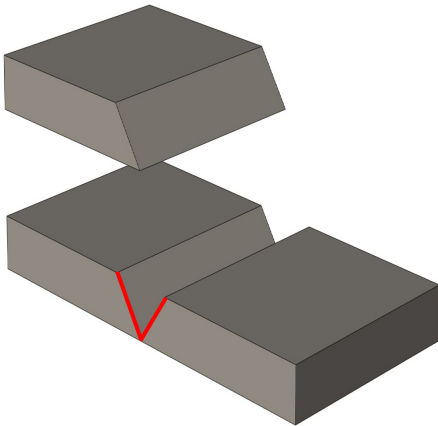
(or straight cuts) are also shown. V cuts and A cuts are single-pass bevel cuts. Y Top cuts require two passes (one cut to establish the straight edge or "land" and a second pass to cut the bevel).

**Note:** The sequence of the multi-pass cuts for the Y Top cut impacts the results. Hypertherm's True Bevel technology process parameter tables provide values based on cutting the land first, followed by the bevel cut.

**Figure 1** – V cut bevel

V cut (single pass):

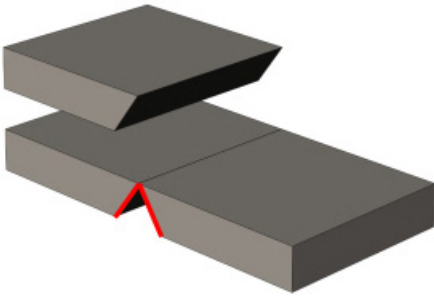
- Conventional "positive" bevel cut
- When two V cut edges are aligned for welding, they form a "V"



**Figure 2** – A cut bevel

A cut (single pass):

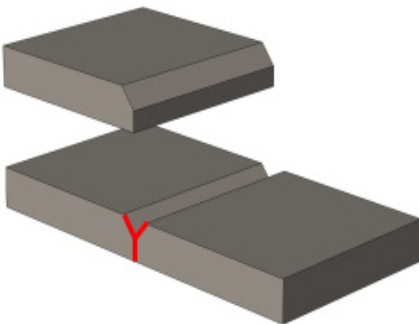
- Conventional “negative” bevel cut
- When two A cut edges are aligned for welding, they form an “A”



**Figure 3** – Y Top bevel

Y Top cut (multi-pass):

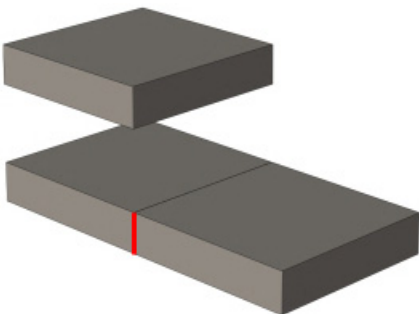
- Conventional “straight” cut on the bottom portion of the cut
- Conventional “positive” bevel cut at the top of the part
- When two Y Top cut edges are aligned for welding, they form a “Y”



**Figure 4** – I cut (straight cut)

I cut (single pass):

- Conventional “straight” cut
- When two I cut edges are aligned for welding, they form an “I”



### Plasma bevel cut type differences

The physics involved with plasma bevel cutting can have different results compared to I cutting, including specific cut variations based on whether you are performing V, A, or Y bevel cuts. These differences are due to changes in the arc attachment point, increased effective cut height, molten metal flow path (for multi-pass bevel cuts), and the impact of gravity on the molten metal flow.

## V and A bevel cutting

There are some differences in plasma cutting between V cuts and A cuts:

V cuts:

- Smooth cut edge appearance similar to I cutting (see *Figure 5*)
- Sharp bottom edge (acute angle)
- Dropped part that is trapped below the skeleton
- Major size (bottom) of the part that varies with material thickness and angle variation because the torch is following a path on top of the plate

A cuts:

- Rougher cut edge appearance (see *Figure 5*)
- Rounded top edge (acute angle) due to high temperature gases being blown directly onto the edge
- Dropped part that rests on top of the skeleton
- Minor size (bottom) that varies with material thickness and angle variation because the torch is following a path on top of the plate
- Major size that is slightly smaller than the V cut due to rounding of the edge (see *Figure 6*)
- Potential inability to achieve 45 degrees for thinner materials\*
  - The compensation values are as high as  $+10.3^\circ$  (meaning a possible angle of  $55.3^\circ$ ), which may require the torch to be tilted beyond the physical limits of many bevel heads
  - The torch is designed to go only to approximately  $48^\circ$  without impacting the clearance or the effective cut height (or both)

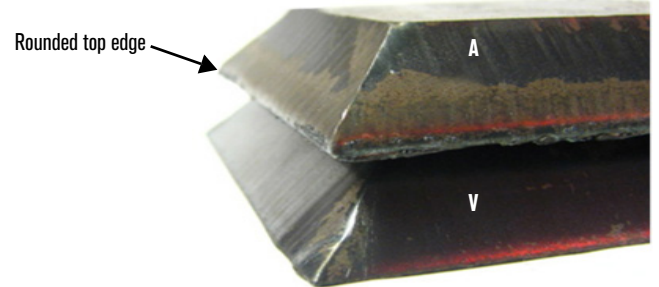
## Y Top bevel cutting

In addition to the bevel angle and overall size of the bevel part being cut, Y Top bevel cuts have a straight land portion (or I cut portion) that defines the desired geometry. The land dimension is a parameter that V cuts and A cuts do not have (see *Figure 7*).

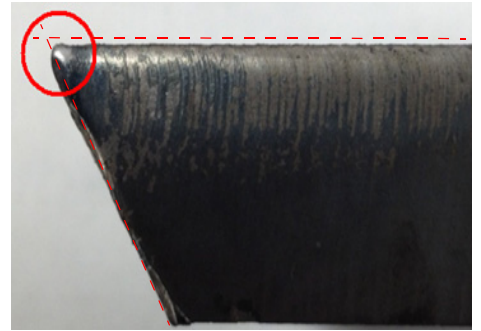
**Note:** The sequence of the multi-pass cuts for the Y Top cut impacts the results. Hypertherm's True Bevel technology process parameter tables provide values based on cutting the land first, followed by the bevel cut.

\* You may produce better cut edges with A cuts when cutting materials 1.5 inches (38 mm) and greater.

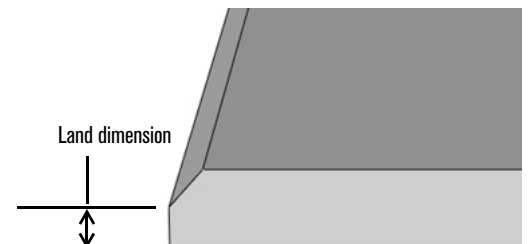
**Figure 5** – V cut–A cut edge comparison



**Figure 6** – A cut part size reduction due to top corner rounding



**Figure 7** – Y Top land dimension



## Thickness coverage

Hypertherm Associates' True Bevel technology process parameter tables contain values for mild steel thicknesses ranging from 0.25 inch (6 mm) to 2 inches (50 mm). This thickness range is covered through the range of HPRXD

bevel processes (80 A to 400 A for mild steel). The thickness/process combinations displayed in *Table 1* and *Table 2* were chosen based on the ability of the process to support bevel cutting up to 45°.

**Table 1** – Thickness coverage – English units (inches)

	0.250	0.312	0.375	0.500	0.625	0.750	0.875	1.000	1.250	1.500	1.750	2.000
80 A	X	X	X									
130 A		X	X	X	X							
200 A				X	X	X	X					
260 A						X	X	X	X	X		
400 A								X	X	X	X	X

**Table 2** – Thickness coverage – metric units (mm)

	6	8	10	12	15	19	20	22	25	32	38	44	50
80 A	X	X	X										
130 A		X	X	X	X								
200 A				X	X	X	X	X					
260 A						X	X	X	X	X	X		
400 A									X	X	X	X	X

## Bevel angle and land density coverage

Hypertherm Associates' True Bevel technology process parameter tables contain values for angles ranging from 15° to 45° for V cuts and A cuts and from 22.5° to 45° for Y Top cuts. The tables contain values for lands ranging from 20% to 50% of the material thickness for Y Top cuts. You can add other angles and land dimensions within the specified ranges into the True Bevel technology process parameter tables for more flexibility. The tables automatically provide newly calculated output values for angle compensation, kerf, cut height, cut speed, and arc voltage.

The angle sign convention is based on whether the top angle (V cut) is considered to be positive or negative by the bevel head. You can automatically set the angle sign within the True Bevel technology process parameter table by selecting the proper top angle orientation (positive or negative) for your bevel head within the table (see *Figure 20* on page 17). The correct signs are then applied to all of the angles.

**Table 3** – V cut and A cut angle coverage

Angle*											
<b>V cut</b>	-45°	-40°	-37.5°	-35°	-30°	-27.5°	-25°	-22.5°	-20°	-17.5°	-15°
<b>A cut</b>	45°	40°	37.5°	35°	30°	27.5°	25°	22.5°	20°	17.5°	15°

\* Angle signs based on negative bias head.

**Table 4** – Y Top cut angle and land coverage

Y Top	Angle*	-45°			-37.5°			-30°			-27.5°			-22.5°		
	Land Dimension	20%	35%	50%	20%	35%	50%	20%	35%	50%	20%	35%	50%	20%	35%	50%

\* Angle signs based on negative bias head.

## Bevel head geometry and nomenclature

The following parameters affect the values in the True Bevel technology process parameter tables:

- Clearance
- Bevel pivot point
- Torch pivot length (TPL)

Other relevant parameters include:

- Process shift
- Process compensation
- Bevel pivot length – this applies only to ABXYZ-type bevel heads
- Maximum tilt angle

## Clearance

*Clearance* is the desired minimum distance between the torch and the top of the plate. The default recommended value in the True Bevel technology process parameter tables for clearance is 0.100 inches (2.5 mm), with a recommended range of 0.080 to 0.160 inches (2 mm to 4 mm).

Higher clearances reduce the likelihood of torch collisions, but they also result in higher effective cut heights (which may produce lower edge quality and require higher angle compensations) and higher cutting voltages (which could impact the duty cycle of the power supply). Hypertherm Associates recommends that you first cut with the default torch clearance settings and adjust only as needed. The True Bevel technology process parameter tables enable you to individually change the torch clearances based on amperage.

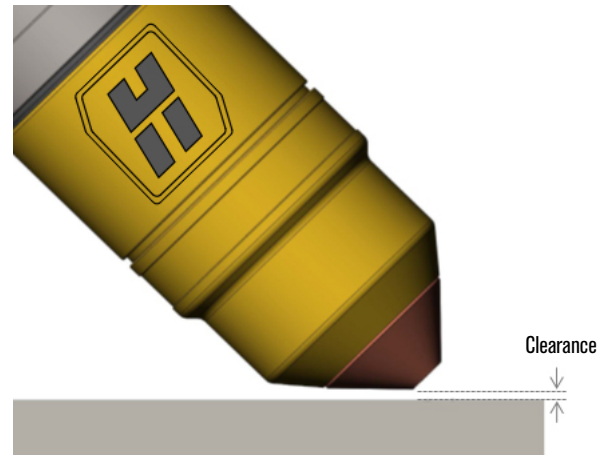
## Bevel pivot point and torch pivot length

The *bevel pivot point* is the point in three-dimensional space that the bevel head tilts around (rotation point) and is typically located at the tip of the torch (or the end of the shield) in many bevel heads.

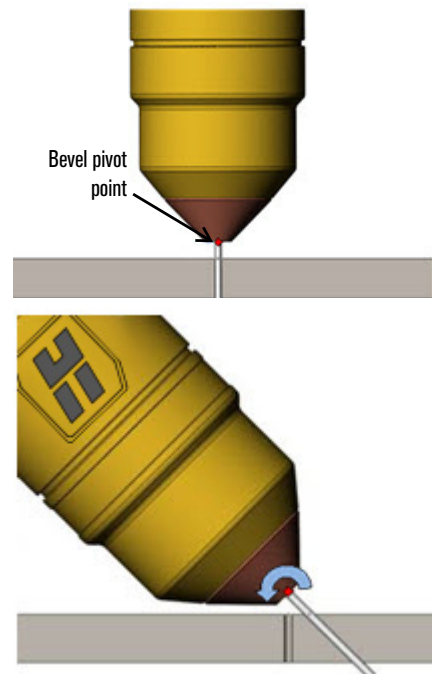
The *torch pivot length* (TPL) is the relationship of the distance between the HPRXD torch and the bevel pivot point on the bevel head.

Proper positioning of the torch relative to the bevel pivot point is essential to achieving acceptable results with minimal material waste. *Figure 9* shows the bevel pivot point located at the tip of a 130 A O<sub>2</sub>/Air shield, as well as the result of tilting the torch 45° around the bevel pivot point.

**Figure 8** – Definition of clearance



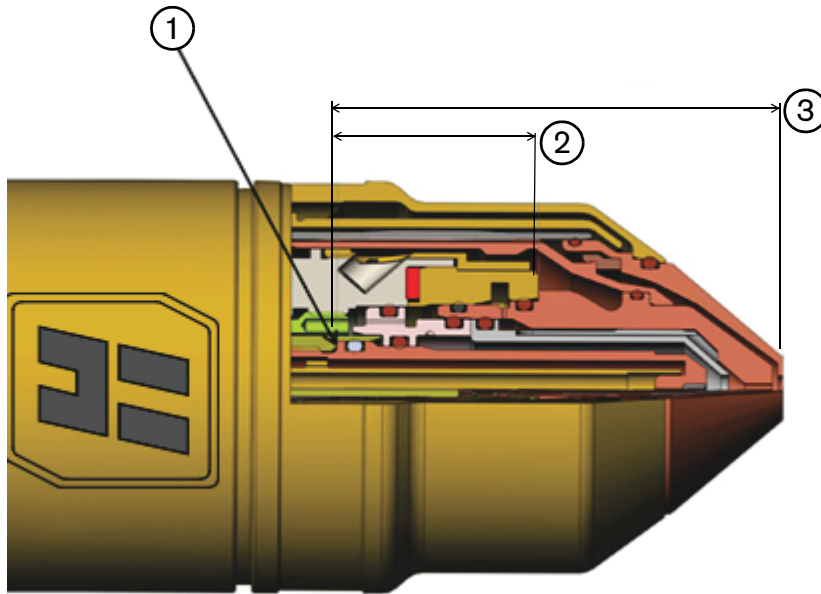
**Figure 9** – Example of the bevel pivot point located at the tip of a 130 A shield



For the purposes of the True Bevel technology process parameter tables, the torch pivot length (TPL) is defined as the distance from the bevel head pivot point to the electrode seat in the HPRXD torch. For reference, the electrode seat is nominally located 0.940 inches (23.88 mm) from the nozzle seat (as shown in *Figure 10*).

As an example, if the torch was positioned within the bevel head such that the bevel pivot point was located at the tip of the 130 A O<sub>2</sub>/Air shield, the TPL would be 2.084 inches (52.93 mm), as shown in *Figure 10*. For a method of determining the TPL, refer to the section *Determining torch pivot length (TPL)* on page 15.

**Figure 10** – Example of the TPL for the bevel pivot point located at the tip of a 130 A shield



- 1 The TPL in the True Bevel technology process parameter tables is measured from the electrode seat
- 2 0.9400 inches (23.88 mm)
- 3 2.0840 inches (52.93 mm)

### Process shift

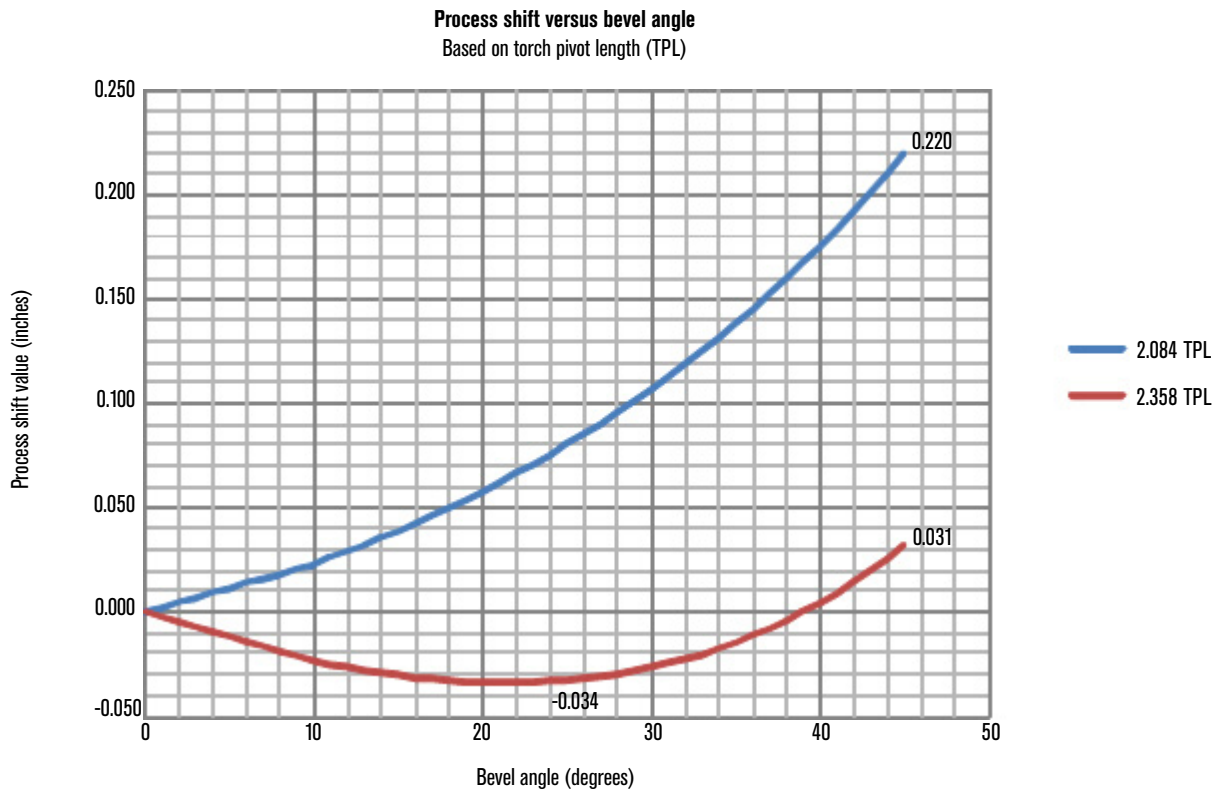
*Process shift* occurs when the plasma arc moves across the top of the plate during the tilting of the torch. For example, *Figure 12* on page 9 shows a 0.220 inch (5.59 mm) process shift resulting from a bevel pivot point located at the tip of the 130 A O<sub>2</sub>/Air shield (with a torch pivot length [TPL] of 2.084 inches [52.93 mm]) and tilted to 45° while maintaining a 0.100 inch (2.5 mm) clearance. *Figure 11* displays a plot illustrating how the process shift values for the 2.084 inch TPL increase with torch tilt.

An optimal location exists for the HPRXD torch relative to the bevel head pivot point that minimizes process shift across all HPRXD bevel processes and angles. This optimal location is defined by a TPL of 2.358 inches (59.89 mm), which places the bevel pivot point 0.274 inches (6.96 mm) beyond the 130 A O<sub>2</sub>/Air shield tip.

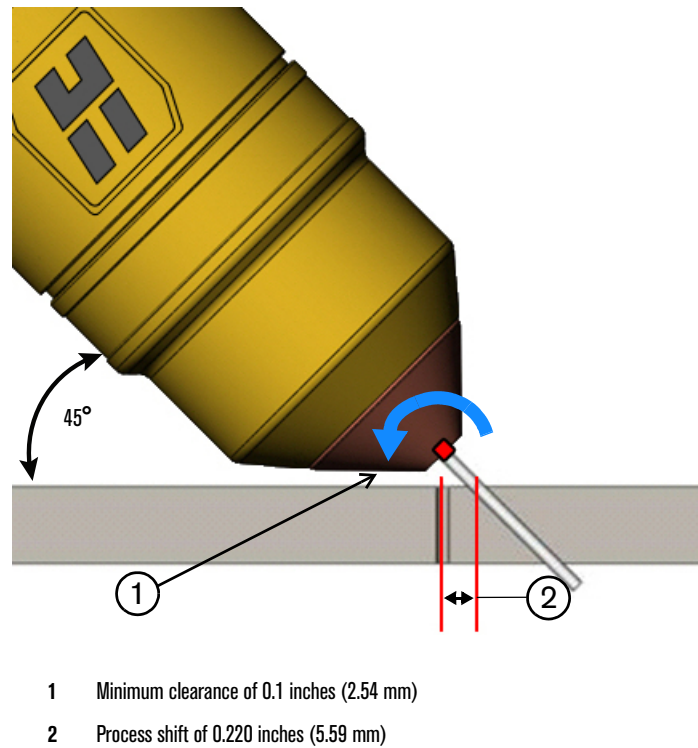
As an example, *Figure 11* plots the process shift for both the tip of the 130 A O<sub>2</sub>/Air shield (2.084 inch TPL) and for the optimal TPL of 2.358 inches. *Figure 13* on page 10 shows a 0.031 inch (0.79 mm) process shift that results from the optimal TPL of 2.358 inches (59.89 mm).



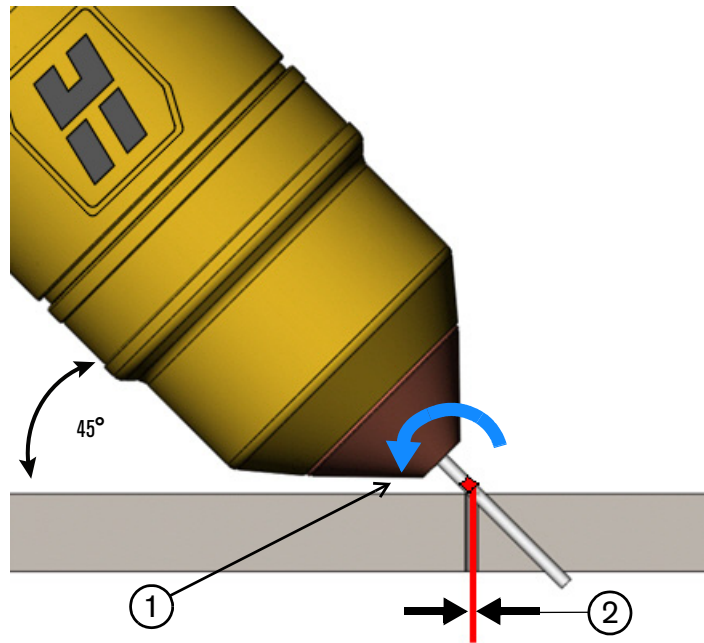
**Figure 11** – Process shift versus bevel angle – optimal TPL of 2.358 inches



**Figure 12** – Impact of the TPL on process shift when TPL = 2.084 inches (52.93 mm)



**Figure 13** – Impact of the TPL on process shift when TPL = 2.358 inches (59.89 mm)



- 1 Minimum clearance of 0.1 inches (2.54 mm)
- 2 Process shift of 0.031 inches (0.78 mm)

### Process compensation

*Process compensation* is an adjustment made to the torch path to compensate for the process shift. You can apply this adjustment to the raw tool path by adding the process compensation value in the CAM software, or you can add the process compensation (multiplied by two) to the kerf value. Hypertherm Associates' ProNest software applies the process compensation values to the raw tool path automatically.

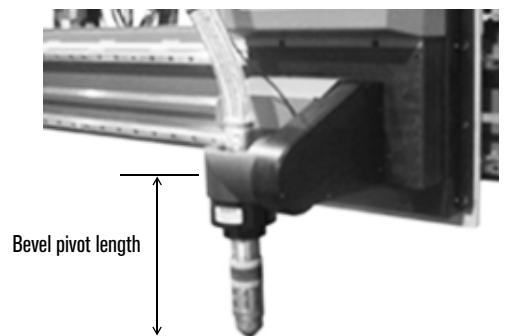
**Note:** Adding twice the process compensation value to the kerf value will not work for many CNCs because negative kerf values can result and may not be supported.

### Bevel pivot length

For the purposes of the True Bevel technology process parameter tables, *bevel pivot length* is defined as the distance from the tip of a loaded 130 A O<sub>2</sub>/Air torch shield to the mechanical rotation point for an ABXYZ-type bevel head. (This type of bevel head uses the X, Y, and Z axes to create a virtual bevel pivot point).

If you use this type of head with a Hypertherm EDGE Pro CNC, you can use the Bevel Pivot Length field in the CNC. The value you enter in this field should be the distance from the 130 A O<sub>2</sub>/Air shield tip to the mechanical rotation point of the bevel head (as shown in *Figure 14*). The bevel pivot length value is already available in some setups with the EDGE Pro CNC.

**Figure 14** – Bevel pivot length for an ABXYZ bevel head

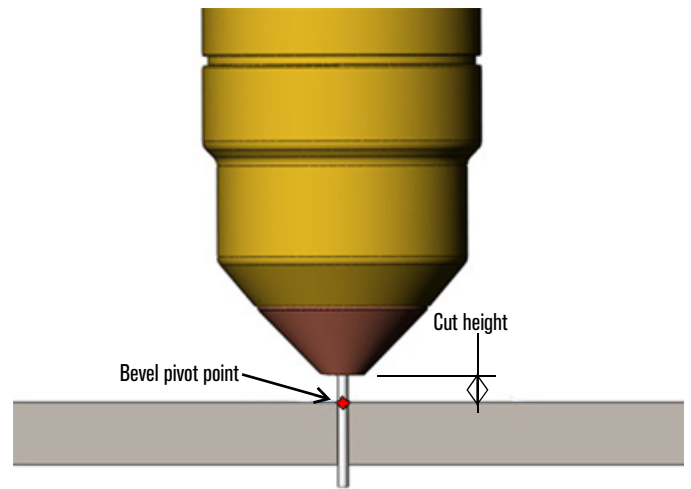


### Special ABXYZ case: adding cut height to the bevel pivot length

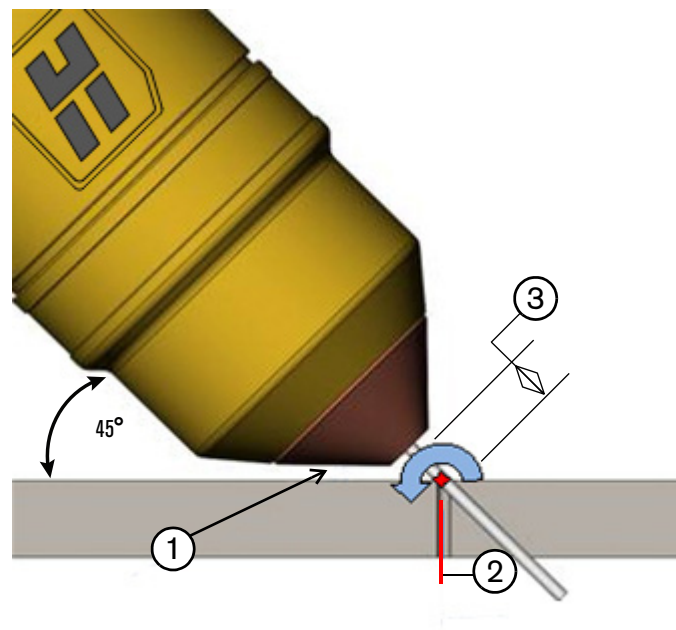
For ABXYZ-type bevel heads, it is possible to maintain the virtual bevel pivot point such that it is always located at the top of the plate. This is accomplished by taking the cut height that is passed to the CNC through the part program code and adding that cut height to the bevel pivot length stored in the CNC.

If the default bevel pivot length is the tip of the shield of the loaded 130 A O<sub>2</sub>/Air consumables, adding the cut height transfers the virtual bevel pivot point from the tip of the shield to top of the plate (as shown in *Figure 15*). This eliminates the need for process compensation and also maximizes plate utilization because there is no shift of the arc across the top of the plate as the torch tilts (see *Figure 16* on page 11 and *Figure 17* on page 12).

**Figure 15** – Virtual bevel pivot point moved to the top of the plate by adding cut height to the bevel pivot length

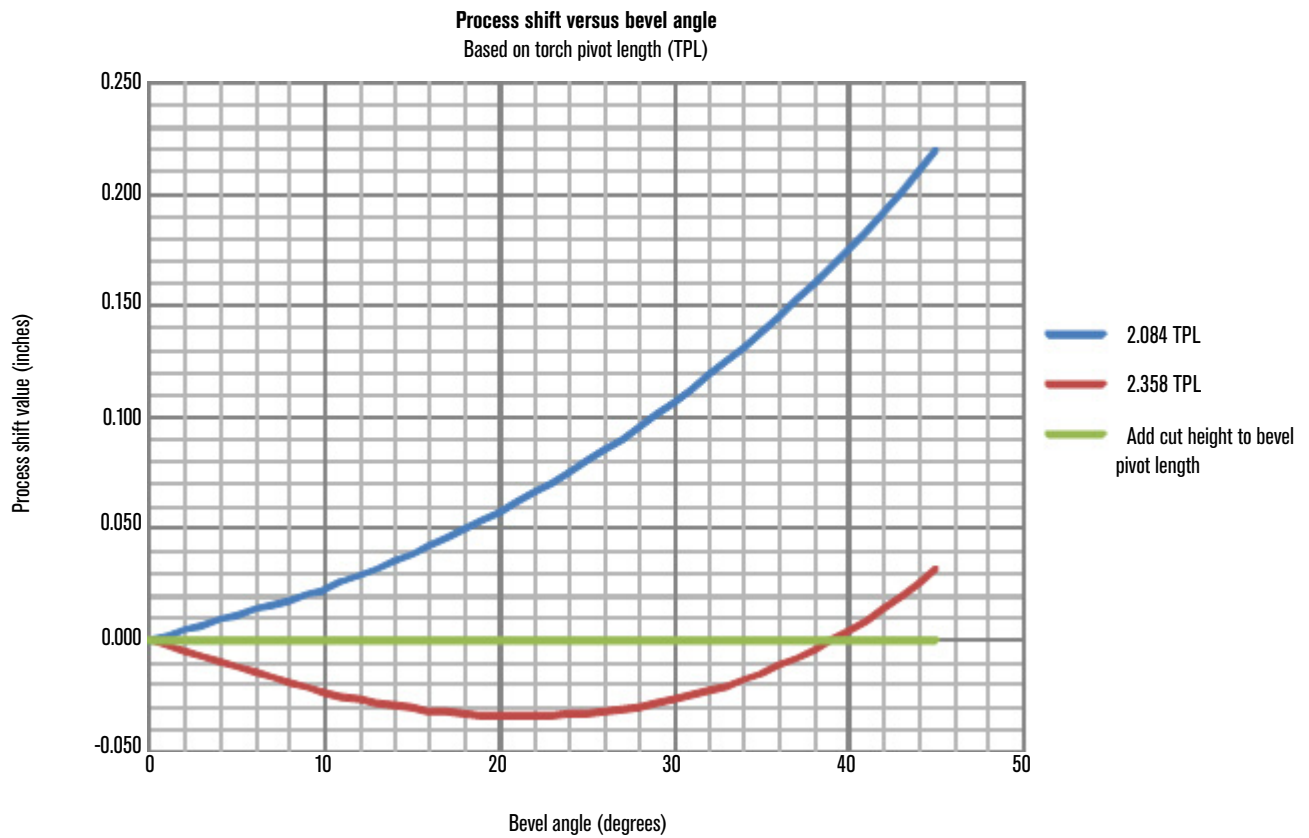


**Figure 16** – Elimination of process shift by adding cut height to the bevel pivot length



- 1 Minimum clearance of 0.1 inches (2.54 mm)
- 2 0 (zero) process shift
- 3 Cut height

**Figure 17** – Process shift versus bevel angle – adding cut height to the bevel pivot length for an ABXYZ head



Because the default bevel pivot length value is based on the 130 A O<sub>2</sub>/Air bevel consumable length, when you use other processes (for example, 200 A) the bevel pivot length value in the CNC needs to be adjusted to compensate for the different lengths.

The Hypertherm EDGEPro CNC can automatically adjust the bevel pivot length value temporarily by adding or subtracting the difference in the length of the consumable sets. This difference (or delta) value can be passed through the part program code with a G93 X.XXX command (Bevel Consumable Correction) at the beginning of the program.

Table 5 contains the length differences for the HPRXD bevel processes (a positive value means the consumables are longer).

**Note:** The True Bevel technology process parameter tables for ProNest users automatically generate the G93 command.

**Table 5** – Bevel consumable length differences relative to 130 A O<sub>2</sub>/Air

Bevel process	80 A O <sub>2</sub> /Air	130 A O <sub>2</sub> /Air	200 A O <sub>2</sub> /Air	260 A O <sub>2</sub> /Air	400 A O <sub>2</sub> /Air
Consumable length delta (inches)	0.000	0.000	0.011	0.035	-0.019
Consumable length delta (mm)	0.00	0.00	0.28	0.89	-0.48

## Maximum tilt angle

By inserting the desired *maximum tilt angle* into the True Bevel technology process parameter table, you can limit the maximum tilt such that a commanded tilt will not exceed the capabilities of the bevel head. Doing so “clips” the tilt commands to the value you specified.

For the HPRXD bevel consumables, the maximum recommended tilt is 48.5° at a clearance of 0.1 inches (2.5 mm). You can select a higher maximum tilt angle if it is within the capabilities of the bevel head and if an increased minimum clearance value is also entered.

## Top angle orientation

*Top angle orientation* is based on how the bevel head reacts when commanded to tilt to either a positive or negative angle command. For example, if a bevel head is commanded to tilt to a positive 45° angle and the result is a 45° V cut (or top bevel cut), the head is considered to have a positive top angle orientation. If the result of the positive 45° angle command is a 45° A cut, the head is considered to have a negative top angle orientation.

## Installing the bevel process parameter files

To implement Hypertherm Associates' True Bevel technology process parameter tables, you will install one of eight possible Microsoft Excel (XLS) spreadsheet files as well as a related dynamic link library (DLL) file. The bevel process parameter spreadsheet that you use is determined by the type of bevel head you are using, as well as your CAM software and CNC setup.

The spreadsheet files contain Hypertherm Associates' True Bevel process parameter cut chart data and are provided for use with Hypertherm Associates ProNest nesting software and/or HPRXD plasma systems at no additional charge to users. Four of the spreadsheets are formatted to work with the ProNest nesting software, while the other four include only the necessary bevel process parameter information and are designed for HPRXD-only users to be used with other CAM and/or CNC packages.

In addition, this paper refers to the following two bevel head classifications as a way to indicate the type of bevel head being used:

- *ABXYZ with Add Cut Height to Bevel Pivot Length enabled*
- *All Other*

Four of the True Bevel technology process parameter spreadsheet files are designed for the *ABXYZ with Add Cut Height to Bevel Pivot Length enabled* classification, and four are designed for the *All Other* classification.

The DLL file is required if you want to modify the spreadsheets. There are two DLL files, one for 32-bit Microsoft Windows operating systems and the other for 64-bit. To use the True Bevel technology process parameter data, the proper XLS spreadsheet and DLL file must be installed on the computer.

*Table 6* identifies the eight spreadsheet (XLS) files and both DLL files. Of the ten files listed in this table, only one spreadsheet and one DLL are required to fully utilize the benefits of the True Bevel technology process parameter tables.

**Table 6** – True Bevel technology process parameter table spreadsheets (XLS) and DLL files

Part number	Description of file	User setup
080009	ABXYZ English ProNest Bevel Compensation XLS	English units <i>ABXYZ with Add Cut Height to Bevel Pivot Length enabled</i> With ProNest
080011	AC English ProNest Bevel Compensation XLS	English units <i>All Others</i> With ProNest
080013	ABXYZ Metric ProNest Bevel Compensation XLS	Metric units <i>ABXYZ with Add Cut Height to Bevel Pivot Length enabled</i> With ProNest
080014	AC Metric ProNest Bevel Compensation XLS	Metric units <i>All Others</i> With ProNest
080017	ABXYZ English HPRXD-only Bevel Compensation XLS	English units <i>ABXYZ with Add Cut Height to Bevel Pivot Length enabled</i> HPRXD only
080019	AC English HPRXD-only Bevel Compensation XLS	English units <i>All Others</i> HPRXD only
080018	ABXYZ Metric HPRXD-only Bevel Compensation XLS	Metric units <i>ABXYZ with Add Cut Height to Bevel Pivot Length enabled</i> HPRXD only

**Table 6** – True Bevel technology process parameter table spreadsheets (XLS) and DLL files

Part number	Description of file	User setup
080020	AC Metric HPRXD-only Bevel Compensation XLS	Metric units <i>All Others</i> HPRXD only
081246	Bevel Cutting Parameters DLL file for 32-bit	All users with 32-bit versions of Windows XP or Windows 7
081247	Bevel Cutting Parameters 64 DLL file for 64-bit	All users with 64-bit versions of Windows XP or Windows 7

## Installation procedure

Contact your Hypertherm Associates representative for details on or assistance with the installation procedure.

## Determining torch pivot length (TPL)

**Note:** This section covers one procedure for determining TPL; other methods can also be used successfully. This procedure assumes that the bevel head mechanics have been verified and that when commanded the bevel head can accurately achieve the desired angle.

If you do not know the TPL, you can determine it if the CNC can display the lifter axis (Z axis) values on the screen. This method uses a designed tool that incorporates a precision tooling ball accurately positioned. Hypertherm Associates offers a bevel head alignment tool (428000) that can be used for this process. This tool has the electrode threads on one end along with a shoulder that engages the electrode seat in the torch. At the opposite end of the tool, a tooling ball is positioned at a known distance from the tool shoulder to the center of the sphere. This distance is referred to as the *ToolDistanceToSphereCenter* dimension. The nominal *ToolDistanceToSphereCenter* dimension for the Hypertherm 428000 tool is 2.2785 inches (57.874 mm).

**Note:** A similar bevel head alignment tool can be used as long as you know the dimensions of the tool (that is, the *ToolDistanceToSphereCenter* dimension).

To determine the TPL (once you know the *ToolDistanceToSphereCenter* dimension for your bevel head alignment tool):

- 1 After the torch is installed into the bevel head, the tool is installed into the torch such that the shoulder is snug against the electrode seat within the torch.
- 2 The lifter is lowered until the tooling ball comes into contact with a level plate surface (or feeler gauge) on the cutting table and the Z value is recorded ( $Z_{0^\circ}$ ). (See *Figure 18*.)
- 3 The torch is raised and is commanded to tilt to a specific angle (for example,  $45^\circ$ ).
- 4 The lifter is again lowered until the tooling ball comes into contact at approximately the same location of the level plate surface (or feeler gauge), and again the Z value is recorded ( $Z_\alpha$ ). (See *Figure 19*.)
- 5 Assuming the positive Z axis direction is down, you can use the following equation to determine the TPL:

$$TPL = \left( \frac{Z_{0^\circ} - Z_\alpha}{1 - \cos(\alpha)} \right) + ToolDistanceToSphereCenter$$

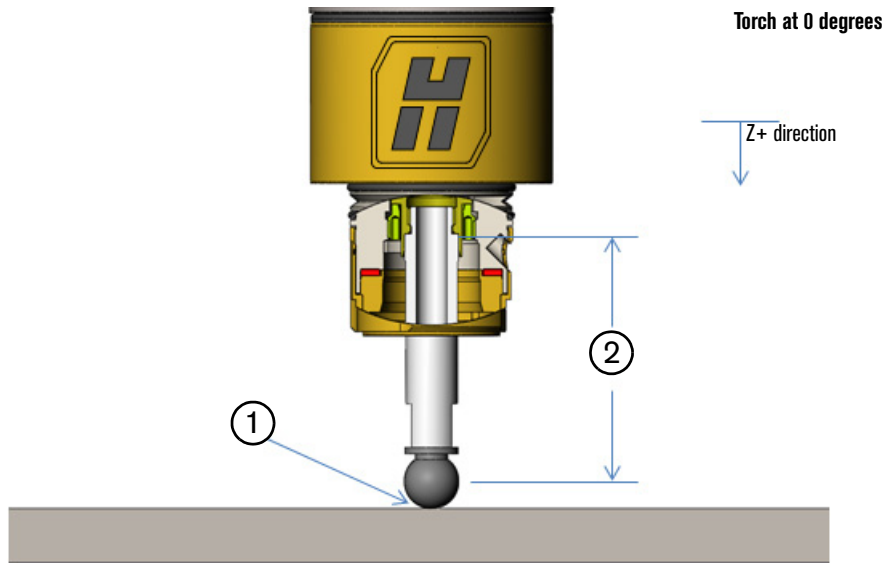
If the downward Z axis direction is negative, you will need to switch the two Z terms in this equation ( $Z_\alpha - Z_{0^\circ}$ ).

*Example:*

While using the Hypertherm 428000 tool, you record the  $Z_{0^\circ}$  value as 2.900 inches. The torch is tilted to  $45^\circ$ , and you record the  $Z_{45^\circ}$  value to be 2.875 inches. The TPL you enter into the True Bevel technology process parameter tables would then be 2.364 inches, as follows:

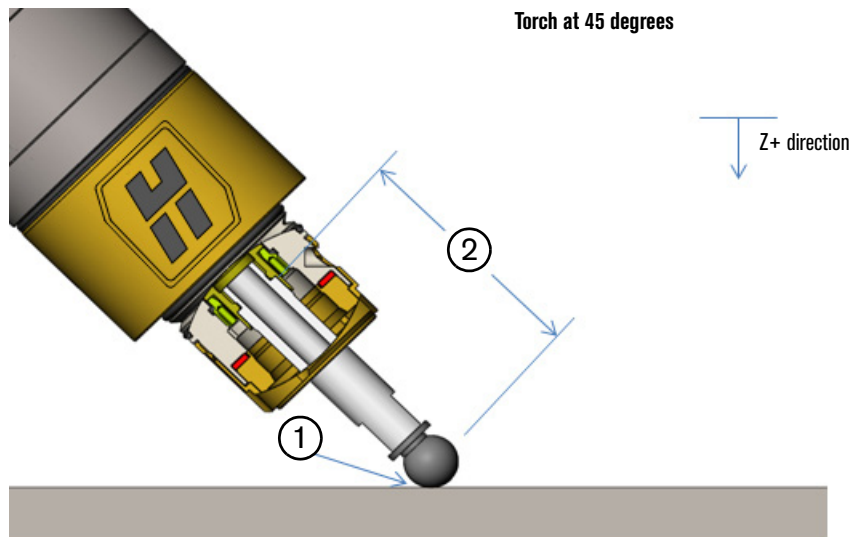
$$TPL = \left( \frac{2.900 - 2.875}{1 - \cos 45^\circ} \right) + 2.2785 = 2.364 \text{ inches}$$

**Figure 18** – Example of using a bevel head alignment tool for determining  $Z_0$ .



- 1 Record the Z value from the CNC as the sphere contacts the plate
- 2 *ToolDistanceToSphereCenter*

**Figure 19** – Example of using a bevel head alignment tool for determining  $Z_{45^\circ}$ .



- 1 Record the Z value from the CNC as the sphere contacts the plate
- 2 *ToolDistanceToSphereCenter*



## How to use the True Bevel technology process parameter tables

As explained in the section *Installing the bevel process parameter files* on page 14, this paper uses the following two bevel head classifications to indicate the type of bevel head being used:

- ABXYZ with Add Cut Height to Bevel Pivot Length enabled
- All Other

For the *ABXYZ with Add Cut Height to Bevel Pivot Length enabled* classification, no process compensation values are used when creating the output part program.

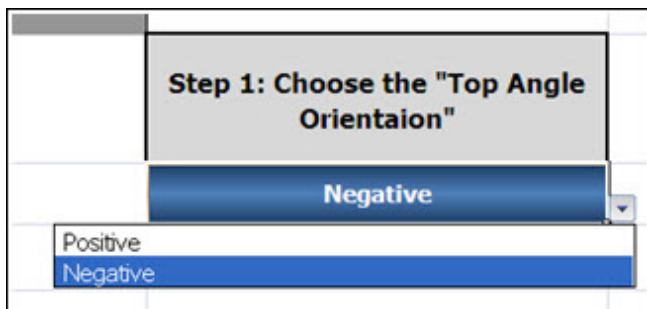
For the *All Other* classification, process compensation values are calculated based on the fixed TPL value entered into the spreadsheet.

To use the True Bevel technology process parameter data, you must have the proper XLS spreadsheet and DLL file installed on the computer.

### Getting started

- 1 Open the True Bevel technology process parameter spreadsheet.
- 2 If prompted in Excel, be sure to enable macros, as this allows the spreadsheet (XLS) file to reference the installed DLL file for any changes made in the spreadsheet.
- 3 Choose the proper top angle orientation (positive or negative), as shown in *Figure 20*. (See *Top angle orientation* on page 13.) You should need to make this selection only once.

**Figure 20** – Top angle orientation selection



- 4 Set the desired minimum clearances (Min Clearance) for each process (as shown in *Figure 21*). The recommended clearance value range is 0.080 inches (2 mm) to 0.160 inches (4 mm); however, the recommended and default clearance value is 0.100 inches (2.5 mm).

If torch collisions are occurring, increasing the minimum clearance value will generate new cut heights and arc voltages to raise the torch farther from the plate without affecting part size. Hypertherm recommends:

- Changing the minimum clearance value only after cutting sample parts
  - Conducting proper arc voltage calibration prior to changing the minimum clearance if the cutting system does not use sampled arc voltage (or a similar technology). Otherwise, the torch collisions may be caused by improper arc voltage rather than improper clearance.
- 5 Set the torch pivot length (TPL) value for the bevel head and torch combination (as shown in *Figure 21*). This applies only to AC-type bevel heads and bevel heads that fall under the *All Others* classification.
  - 6 Set the maximum tilt angle (Max Tilt Angle) for the bevel head (as shown in *Figure 21*). This is the maximum angle that will be programmed in a part program.

**Figure 21** – Setting minimum clearance, TPL (AC-type and *All Others* only), and maximum tilt angle

Step 2: Insert the minimum clearance values (recommended clearance: 0.080 in - 0.16 in), TPL value, and max tilt angle. See "Geometry Definitions" sheet for graphics.					
	80Amp	130Amp	200Amp	260Amp	400Amp
Min Clearance	0.10	0.10	0.10	0.10	0.10
TPL	2.358				
Max Tilt Angle	48.3				

**Note:** For thin materials and high angles, head angles in excess of 48° are sometimes required to obtain the correct angle on the part. Many heads, however, cannot tilt over 45° to 48°. When the maximum tilt angle limits the tilt angle output, the "Desired Bevel Angle" and "Signed Angle Adjustment" values will be formatted with a rose color background and a red font in the spreadsheet to indicate that the tilt output has been "clipped" (as shown in *Figure 22*). When the output angles are clipped, you may not be able to achieve the desired angle in the cut.

**Figure 22** – Maximum tilt angle causing clipped tilt angle output

Process Parameters									
Bevels				Kerf Controls					
Enter Desired BevelAngle Here	Bevel Type	Signed BevelAngle	Land Dimension	LeadIn Feedrate	Base Feedrate	Feedrate	Kerf	Signed Angle Adjustment	Co
0	*	0			110	110	0.074		
0	y	0			110	110	0.074		
0	k	0			110	110	0.074		
45	a	45			110	76	0.240	3.300	
40	a	40			110	76	0.226	8.300	
37.5	a	37.5			110	76	0.213	10.510	

### True Bevel technology process parameter table input and output values

For HPRXD-only users, the bevel process parameter spreadsheet outputs the required process parameters to successfully locate the HPRXD torch and produce the desired bevel cut outcome based on the user inputs. The HPRXD-only inputs and outputs are shown in *Table 7*.

**Note:** ProNest users have additional process and loop details to fully define the bevel cutting process.

**Table 7** – Description of bevel process parameter input and output parameters (HPRXD-only users)

Parameter	Description	Type
<b>Material</b>	Material type (currently supporting only mild steel [MS])	Input
<b>Thickness</b>	Material thickness (inches or mm)	Input
<b>Class</b>	Process current level and gas types	Input
<b>Enter Desired Bevel Angle Here</b>	Desired bevel angle (absolute value, no sign association) (degrees)	Input

**Table 7** – Description of bevel process parameter input and output parameters (HPRXD-only users)

Parameter	Description	Type
<b>Bevel Type</b>	V cut (v), A cut (a), Y Top cut (y)	Input
<b>Signed Bevel Angle</b>	Desired bevel angle with appropriate sign applied based on the Top Angle Orientation selection. This value combined with the Signed Angle Adjustment is needed for the output part program code (degrees).	Output
<b>Land Dimension</b>	Desired land dimension for Y Top cuts (inches or mm)	Input
<b>LeadIn Feedrate</b>	No values supplied – use the value from the Feedrate column	Not used
<b>Base Feedrate</b>	Feedrate for I cuts (ipm or mm/min)	Output
<b>Feedrate</b>	Calculated feedrate for the desired bevel cut. This value is needed for the output part program code (ipm or mm/min).	Output
<b>Kerf</b>	Calculated kerf value for the desired bevel cut. This value is needed for the output part program code (inches or mm).	Output
<b>Signed Angle Adjustment</b>	Calculated angle compensation for the desired bevel cut with the appropriate sign applied based on the Top Angle Orientation selection. This value combined with the Signed Bevel Angle are needed for the output part program code (degrees).	Output
<b>Process Compensation</b> (applies to <i>ABXYZ with Add Cut Height to Bevel Pivot Length</i> enabled classification only)	Process shift adjustment. The default value for <i>ABXYZ with Add Cut Height to Bevel Pivot Length</i> enabled bevel head types is blank because there is no process shift (inches or mm).	Not used
<b>Process Compensation</b> (applies to <i>AC-type and All Others</i> classification)	Process shift adjustment. This value is needed for the output part program code (inches or mm).	Output
<b>Transfer Height</b>	Height of the torch for transferring the arc to the plate. This value is needed for the output part program code (percentage of cut height).	Output
<b>Pierce Height</b>	Height of the torch during piercing operation. This value is needed for the output part program code (percentage of cut height).	Output
<b>Pierce Time</b>	Delay time for the arc to penetrate the plate. This value is needed for the output part program code (seconds).	Output
<b>Cut Height</b>	Calculated cut height that provides the minimum desired clearance at the desired bevel angle while maintaining the cut height as close as possible to the cut height value for the effective thickness being cut. This value is needed for the output part program code (inches or mm).	Output
<b>Arc Voltage</b>	Calculated arc voltage based on cut speed, cut height, and effective material thickness. This value may be needed for the output part program code (volts).  <b>Note:</b> The calculated values are based on new consumables and a laboratory setup. Some compensation may need to be done to account for machine differences. If sample arc voltage routines are not used, the operator will need to make adjustments to the arc voltage as the consumables wear in order maintain part size.	Output
<b>Delta Bevel Pivot Length</b> (applies to <i>ABXYZ with Add Cut Height to Bevel Pivot Length</i> enabled classification only)	Difference in consumable length as compared to the 130 AO <sub>2</sub> /Air bevel consumables. This value may be needed for the output part program code (inches or mm).	Output
<b>Bevel A Deg Per Sec</b>	Recommended tilt speed. This value may be needed for the output of the part program code (degrees/second).	Output

## Additional Y Top cut outputs

In addition to the inputs and outputs listed previously, multi-pass bevel cuts have inputs and outputs specifically related to the I cut portion of the bevel cut. In the spreadsheet, these values are found in the gray header area for the thickness section in the y=0 row, as shown in *Figure 23*. Outputs for the I portion of the Y Top cut should be taken from this row.

**Note:** The sequence of the multi-pass cuts for the Y Top cut impacts the results. The True Bevel technology process parameter tables provide values based on cutting the land first, followed by the bevel cut.

**Figure 23** – I cut portion of Y Top cut parameters stored in the highlighted row

Process Parameters									
Bevels					Kerf Controls				
Enter Desired BevelAngle Here	Bevel Type	Signed BevelAngle	Land Dimension	LeadIn Feedrate	Base Feedrate	Feedrate	Kerf	Signed Angle Adjustment	Process Compensation
22.5	y	-22.5	0.063		132	60	0.126	0.478	
0	*	0			110	110	0.080		
0	y	0			110	110	0.080		
0	k	0			110	110	0.080		
45	a	45			110	69	0.201	3.300	
40	a	40			110	73	0.185	6.278	
37.5	a	37.5			110	77	0.178	6.019	
35	a	35			110	82	0.171	5.752	
NA	-	NA			NA	NA	NA	NA	NA

## Making modifications to the True Bevel technology process parameter tables

The True Bevel technology process parameter tables include a relatively dense range of angles along with three different land sizes that should be sufficient for most beveling needs. However, if you need a different angle or land size, you can modify the spreadsheet. For best results, Hypertherm Associates recommends staying within the range of angles and lands that are currently in the spreadsheet (in other words, extrapolation results are unknown). You can perform modifications using either of the following two methods:

- Altering an existing row: change the values in the input columns for Desired Bevel Angle, Bevel Type, and/or Land Dimension – the spreadsheet will generate new output values based on the new inputs

- Copying and inserting a new row: after you insert a row, enter the desired values into the input columns – the spreadsheet will generate new output values based on the inputs

Additional modifications are also possible, such as modifying the desired minimum clearance values.

**Note:** Calculated outputs based on adding new thicknesses, material types, or classes to the spreadsheet are not supported.

## Making final adjustments (if necessary)

The values in the True Bevel technology process parameter tables should result in a part that is close to the desired dimensions, but some fine tuning may be necessary. Use the guidelines in the following section to make the final adjustments. Before performing any tests, check to make sure that the plate is level.

**Note:** Actual results will vary based on bevel head performance. Consult your bevel head table manufacturer to determine the expected tolerance levels that can be achieved with your system. In addition to plasma variability, many other factors will determine the capability of your system, including table motion, bevel head motion, transformation equations, lifter performance, and arc voltage control.

### V cuts and A cuts

- 1 Bevel angle adjustment (as shown in *Figure 24*): For best results, the angle adjustments should be completed first. After cutting a test part from a level plate, measure the angle and determine the difference between the measured angle and the desired angle. Add the difference to or subtract it from the value displayed in the “Signed Angle Adjustment” column in the spreadsheet, and overwrite the value in the cell with the new adjustment value. Recut the part with the new setting to verify that the angle is now correct before proceeding to the next step. If it is not correct, repeat this step.

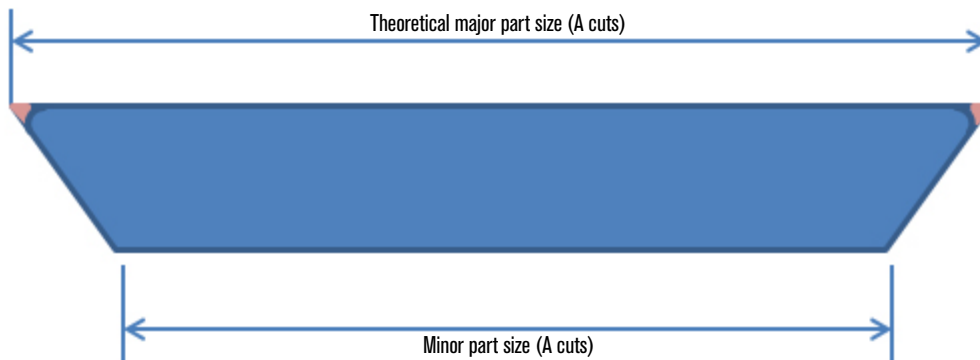
**Figure 24** – V cut and A cut bevel angle



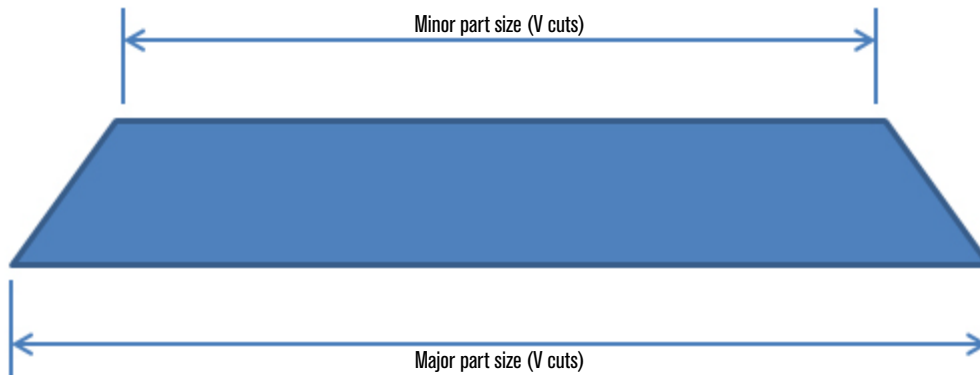
- 2 Part size adjustment (as shown in *Figure 25* and *Figure 26*): After you have achieved the desired angle, measure the size of the part and determine the difference between the measured size and the desired size. Add the difference to or subtract it from the value displayed in the “Process Compensation” column in the spreadsheet, and overwrite the value in the cell with the new adjustment value (note that process compensation is applied per side). Recut the part with the new setting to verify that the size is now correct. If it is not correct, repeat this step.

**Note:** When you measure the size of A cut parts, Hypertherm Associates recommends that you take measurements at the minor side of the part (due to corner rounding), or, if possible, that you take measurements to the theoretical corner. Measuring the size of V cut parts can be done at either the minor or the major side of the part, but for best results the minor side should be used to eliminate error due to material thickness variations.

**Figure 25** – A cut part size



**Figure 26** – V cut part size

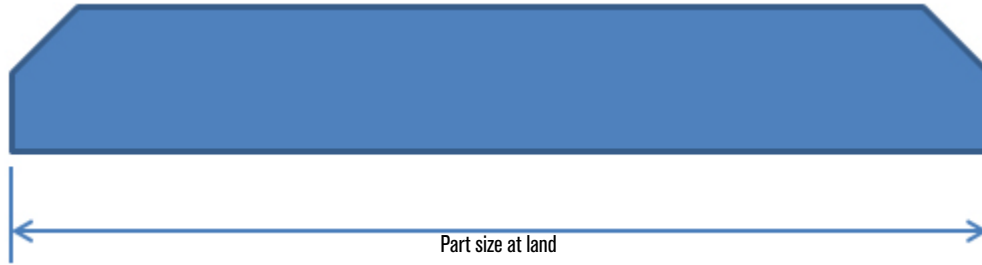


- 3 Save the XLS file. Note that formulae that have been overwritten will no longer be active.

## Y Top cuts

- 1 Part size at land adjustment (as shown in *Figure 27*): For best results, complete the part size adjustments at the land first. After cutting a test part from a level plate, measure the part size at the land and determine the difference between the measured size and the desired size. Add the difference to or subtract it from the value in the “Process Compensation” column in the gray header area of the spreadsheet for the thickness section in the  $y-0^\circ$  row, as shown in *Figure 30* on page 24 (note that process compensation is applied per side). Recut the part with the new setting to verify that the size is now correct. If it is not correct, repeat this step.

**Figure 27** – Y Top cut part size at land



- 2 Part angle adjustment (as shown in *Figure 28*): After you have achieved the desired part size at land, measure the angle of the bevel and determine the difference between the measured angle and the desired angle. Add the difference to or subtract it from the value displayed in the “Signed Angle Adjustment” column in the spreadsheet, and overwrite the value in the cell with the new adjustment value. Recut the part with the new setting to verify that the angle is now correct before proceeding to the next step. If it is not correct, repeat this step.

**Figure 28** – Y Top cut bevel angle



- 3 Part land dimension adjustment (as shown in *Figure 29*): After you have achieved the desired angle, measure the land dimension and determine the difference between the measured land dimension and your desired land dimension. Use the following formula to determine the proper adjustment to the process compensation:

$$\text{Process Compensation Adjustment} = \text{Land Dimension Difference}(\tan[\alpha])$$

where  $\alpha$  = the actual angle. Add the calculated adjustment value to or subtract it from the value displayed in the "Process Compensation" column in the spreadsheet, and overwrite the value in the cell with the new adjustment value. Recut the part with the new setting to verify that the land dimension is now correct. If it is not correct, repeat this step.

- 4 Save the XLS file. Note that formulae that have been overwritten will no longer be active.

**Note:** The sequence of the multi-pass cuts for the Y Top cut impacts the results. The True Bevel technology process parameter tables provide values based on cutting the land first, followed by the bevel cut.

**Figure 29** – Y Top cut land dimension



**Figure 30** – Y cut part size at land adjustment using process compensation

Part Attributes			Process Parameters										Cut Chart Type
Material	Thickness	Class	Bevels				Kerf Controls						
			Enter Desired Bevel Angle Here	Bevel Type	Signed Bevel Angle	Land Dimension	LeadIn Feedrate	Base Feedrate	Feedrate	Kerf	Signed Angle Adjustment	Process Compensation	
MS	0.3750	130Amp O2/Air Bevel (True Hole)	45	y	-45	0.075		110	40	0.190	2.485		35
MS	0.3750	130Amp O2/Air Bevel (True Hole)	37.5	y	-37.5	0.075		110	44	0.157	2.057		35
MS	0.3750	130Amp O2/Air Bevel (True Hole)	30	y	-30	0.075		110	49	0.136	2.223		35
MS	0.3750	130Amp O2/Air Bevel (True Hole)	27.5	y	-27.5	0.075		110	50	0.130	2.183		35
MS	0.3750	130Amp O2/Air Bevel (True Hole)	22.5	y	-22.5	0.075		110	51	0.120	1.662		35
MS	0.5000	130Amp O2/Air Bevel (True Hole)	0	.	0			80	80	0.099			35
MS	0.5000	130Amp O2/Air Bevel (True Hole)	0	y	0			80	80	0.099			35
MS	0.5000	130Amp O2/Air Bevel (True Hole)	0	k	0			80	80	0.099			35
MS	0.5000	130Amp O2/Air Bevel (True Hole)	45	a	45			80	44	0.259	3.306		35
MS	0.5000	130Amp O2/Air Bevel (True Hole)	40	a	40			80	49	0.222	4.660		35
MS	0.5000	130Amp O2/Air Bevel (True Hole)	37.5	a	37.5			80	53	0.206	4.620		35
MS	0.5000	130Amp O2/Air Bevel (True Hole)	35	a	35			80	56	0.192	4.522		35
MS	0.5000	130Amp O2/Air Bevel (True Hole)	30	a	30			80	63	0.169	4.153		35



## Other Hypertherm bevel accessories

---

Hypertherm Associates offers some accessories specifically designed for bevel and robotic applications. These include:

- Rotational mounting sleeve (220864)
  - The rotational sleeve is designed for use in applications where the torch leads are twisted repeatedly.
- Rotational mounting sleeve clamp (220900)
  - This clamp is necessary because the rotational sleeve has a larger diameter than standard sleeves (2.25 inches [57 mm]).
- Bevel head alignment tool (428000)
  - Use this tool to determine the bevel pivot point. (See *Determining torch pivot length (TPL)* on page 15.)

Find additional information on True Bevel at [www.hypertherm.com/truebevel](http://www.hypertherm.com/truebevel)

HPR, EDGE, Phoenix, True Bevel, ProNest, SureCut, and Hypertherm are trademarks of Hypertherm, Inc. and may be registered in the United States and/or other countries. All other trademarks are the property of their respective holders.

Please visit [www.hypertherm.com/patents](http://www.hypertherm.com/patents) for more details about Hypertherm Associates patent numbers and types.

© 08/2023 Hypertherm, Inc. Revision 3

807830



As 100% Associate owners, we are all focused on delivering a superior customer experience. [www.hyperthermassociates.com/ownership](http://www.hyperthermassociates.com/ownership)

Environmental stewardship is one of Hypertherm Associates' core values. [www.hyperthermassociates.com/environment](http://www.hyperthermassociates.com/environment)

100% Associate-owned

