

HPR260[®] and HPR260XD[®] Replacement Transformer Wiring

Field Service Bulletin

808270 Revision 0 June 2014

Hypertherm[®]

Hypertherm Inc.

Etna Road, P.O. Box 5010
Hanover, NH 03755 USA
603-643-3441 Tel (Main Office)
603-643-5352 Fax (All Departments)
info@hypertherm.com (Main Office Email)
800-643-9878 Tel (Technical Service)
technical.service@hypertherm.com (Technical Service Email)
800-737-2978 Tel (Customer Service)
customer.service@hypertherm.com (Customer Service Email)
866-643-7711 Tel (Return Materials Authorization)
877-371-2876 Fax (Return Materials Authorization)
return.materials@hypertherm.com (RMA email)

Hypertherm Plasmatechnik GmbH

Technologiepark Hanau
Rodenbacher Chaussee 6
D-63457 Hanau-Wolfgang, Deutschland
49 6181 58 2100 Tel
49 6181 58 2134 Fax
49 6181 58 2123 (Technical Service)

Hypertherm (S) Pte Ltd.

82 Genting Lane
Media Centre
Annexe Block #A01-01
Singapore 349567, Republic of Singapore
65 6841 2489 Tel
65 6841 2490 Fax
65 6841 2489 (Technical Service)

Hypertherm (Shanghai) Trading Co., Ltd.

Unit 301, South Building
495 ShangZhong Road
Shanghai, 200231
PR China
86-21-60740003 Tel
86-21-60740393 Fax

Hypertherm Europe B.V.

Vaartveld 9
4704 SE
Roosendaal, Nederland
31 165 596907 Tel
31 165 596901 Fax
31 165 596908 Tel (Marketing)
31 165 596900 Tel (Technical Service)
00 800 4973 7843 Tel (Technical Service)

Hypertherm Japan Ltd.

Level 9, Edobori Center Building
2-1-1 Edobori, Nishi-ku
Osaka 550-0002 Japan
81 6 6225 1183 Tel
81 6 6225 1184 Fax

Hypertherm Brasil Ltda.



Rua Bras Cubas, 231 – Jardim Maia
Guarulhos, SP - Brasil
CEP 07115-030
55 11 2409 2636 Tel
55 11 2408 0462 Fax

Hypertherm México, S.A. de C.V.

Avenida Toluca No. 444, Anexo 1,
Colonia Olivar de los Padres
Delegación Álvaro Obregón
México, D.F. C.P. 01780
52 55 5681 8109 Tel
52 55 5683 2127 Fax

Hypertherm Korea Branch

#3904 Centum Leaders Mark B/D,
1514 Woo-dong, Haeundae-gu, Busan
Korea, 612-889
82 51 747 0358 Tel
82 51 701 0358 Fax

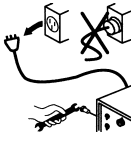
		<p style="text-align: center;">DANGER ELECTRIC SHOCK CAN KILL</p>
	<p>Disconnect electrical power before performing any maintenance.</p> <p>All work requiring removal of the power supply cover must be performed by a qualified technician.</p> <p>See the <i>Safety</i> section of the system's manual for more safety precautions.</p>	

Introduction

The HPR260 and HPR260XD transformer, part number 014295, has changed. The new transformer became incorporated into these plasma systems starting with serial number 005469. The new transformer is compatible with older HPR260 and HPR260XD plasma systems but requires different primary wiring. When replacing the transformer in HPR260 and HPR260XD plasma systems, use these instructions to wire the transformer properly.

Failure to follow the new wiring instructions in this Field Service Bulletin will result in damage not covered by product warranty.

Purpose

This Field Service Bulletin provides a guide to making the primary wiring connections between the main contactor and the new transformer of the HPR260 or HPR260XD plasma system. These connections require the use of a new wire group if the plasma system meets the following criteria:

- HPR260XD 400 – 415 V with serial numbers 005468 and earlier (transformer 014295 Rev F or earlier)
- HPR260XD 200 – 208 V with serial numbers 005468 and earlier (transformer 014295 Rev F or earlier)
- All HPR260 400 – 415 V and 200 – 208 V



All new HPR260XD plasma systems with serial numbers 005469 and higher do not require the new wire group. When replacing the transformer in a new HPR260XD, use the existing wiring.

HPR260 and HPR260XD transformer replacement kit contents (428329)

Part number	Description	Quantity
014295	HPR260XD/HPR260 transformer	1
229614	Wire group	1
104423	Heatshrink tubing, 89 mm (3.5 inches) 200 – 208 V systems use only 21 pieces.	24
104450	Heatshrink tubing, 100 mm (4 inches) Used in 200 – 208 V systems only.	3
075728	Mounting screws Used in 200 – 208 V systems only.	3

Required tools and materials

- Wrenches: 3/8 inch, 7/16 inch, and 3/4 inch
- Hot air gun to shrink the tubing
- The procedure for 400 V and 415 V systems starts on page 5.
- The procedure for 200 V/208 V systems starts on page 8.

HPR260 and HPR260XD 400 V and 415 V models

Before you begin the wiring:

- For ease of installation, make the wire connections starting from the bottom of the transformer with the C connections and working your way up to the A connections.
- Slide the heatshrink tubing onto the wire before connecting the wire.
- Tighten all transformer wiring connections to 98 cm·kg (85 in-lb).
- Stack the wires as shown in Figure 1

Figure 1

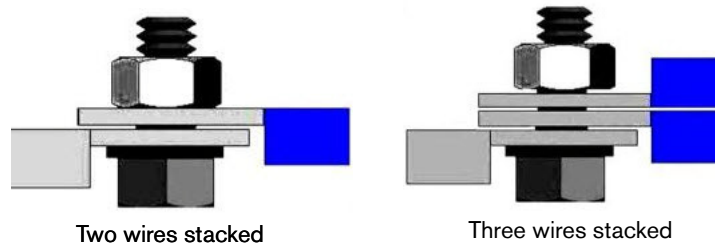

1. Before fastening the new transformer to the plasma system base, be sure the transformer is pulled toward the open side so that the transformer secondary wires have enough clearance from the center panel. This clearance is especially important for the HPR260 and for early model HPR260XD systems. Maneuver the transformer to allow as much clearance as possible but still use the existing bolt holes drilled into the base.
 - No metal from the secondary wires can touch the center panel.
 - The kit includes additional heatshrink tubing for the secondary wire connections.
2. Fasten the transformer to the base using the 3/4 inch wrench and tighten to 737 cm·kg (640 in-lbs).

3. From the old transformer, discard the wires that connect C1 to B1 and B1 to A1. See Figure 2.

Figure 2

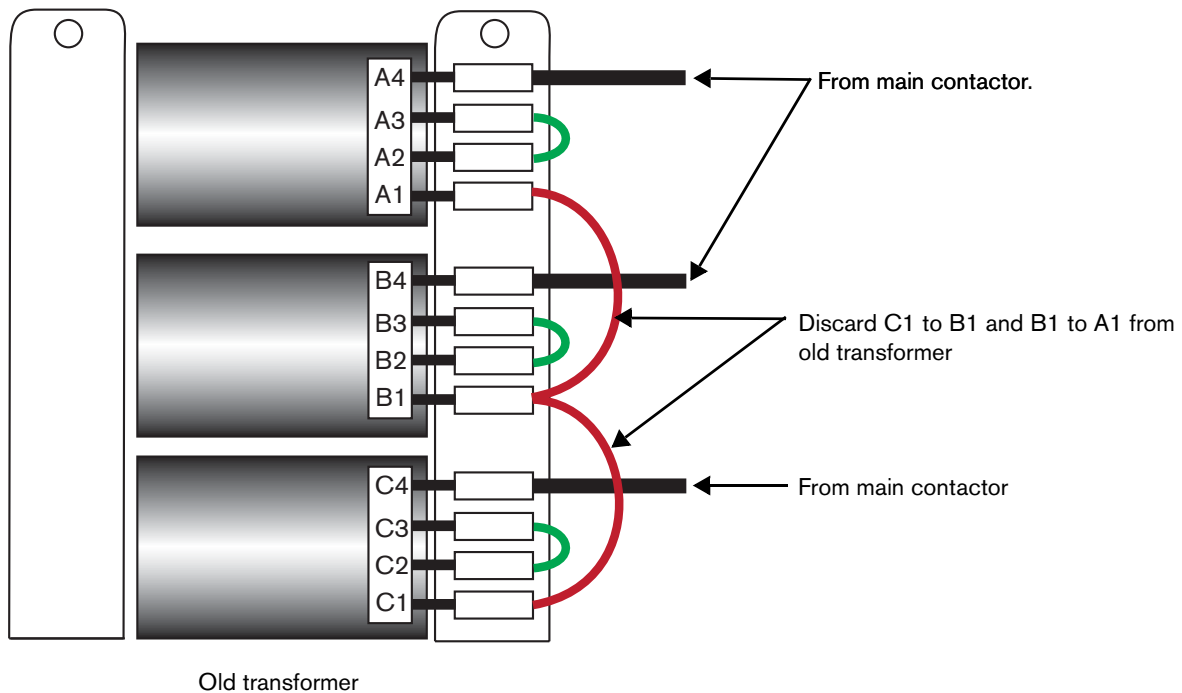

4. Reuse the wires that connect C2 and C3, B2 and B3, and A2 and A3 as shown in Figure 3.
- ❑ Use one piece of 75 mm (3 inch) heatshrink tubing (104423) on connections C2, B2, and A2.
 - ❑ Use 2 pieces of 75 mm (3 inch) heatshrink tubing (104423) on connections: C3, B3, A3.

- From the new wire group, use the two short wires to connect C4 to B1 and B4 to A1. Use one piece of 75 mm (1 inch) heatshrink tubing (104423) on each connection.
- Use the long wire to connect C1 to A4. Use one piece of 75 mm (1 inch) heatshrink tubing (104423) on each connection.

Figure 3

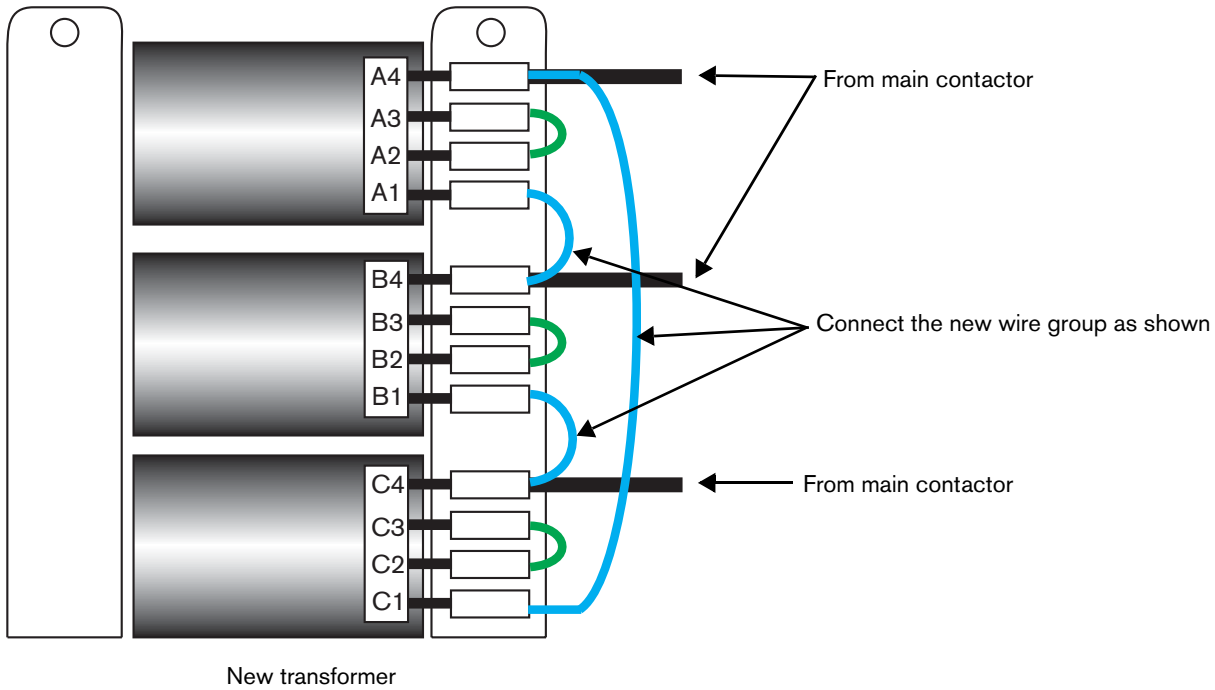

- Use 6 of the remaining pieces of heatshrink tubing (104423) to insulate the secondary wire connections 1A, 2A, 1B, 2B, and 1C, 2C connections to the chopper. These connections are not shown in the illustration.

 HPR260XD 400 – 415 V plasma systems with serial number 005468 or higher use the wiring shown in Figure 3.

HPR260 and HPR260XD 200/208 V model

Before you begin the wiring:

- For ease of installation, make the wire connections starting from the bottom of the transformer with the C connections and working your way up to the A connections.
- Slide the heatshrink tubing onto the wire before connecting the wire.
- Tighten all connections to 98 cm·kg (85 in-lb).
- Stack the wires as shown in Figure 4

Figure 4

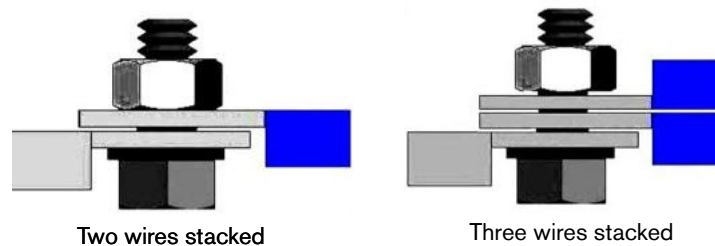

1. Before fastening the new transformer to the plasma system base, be sure the transformer is pulled toward the open side so that the transformer secondary wires have enough clearance from the center panel. This clearance is especially important for the HPR260 and early model HPR260XD systems with serial numbers 005468 and earlier. Maneuver the transformer to allow as much clearance as possible but still use existing bolt holes drilled into the base.
 - No metal from the secondary wires can touch the center panel.
 - The kit includes additional heatshrink tubing for the secondary wire connections.
2. Fasten the transformer to the base using the 3/4 inch wrench and tighten to 737 cm·kg (640 in-lbs).

3. Discard the wires that connect C3 to B1 and B3 to A1. See Figure 5.

Figure 5

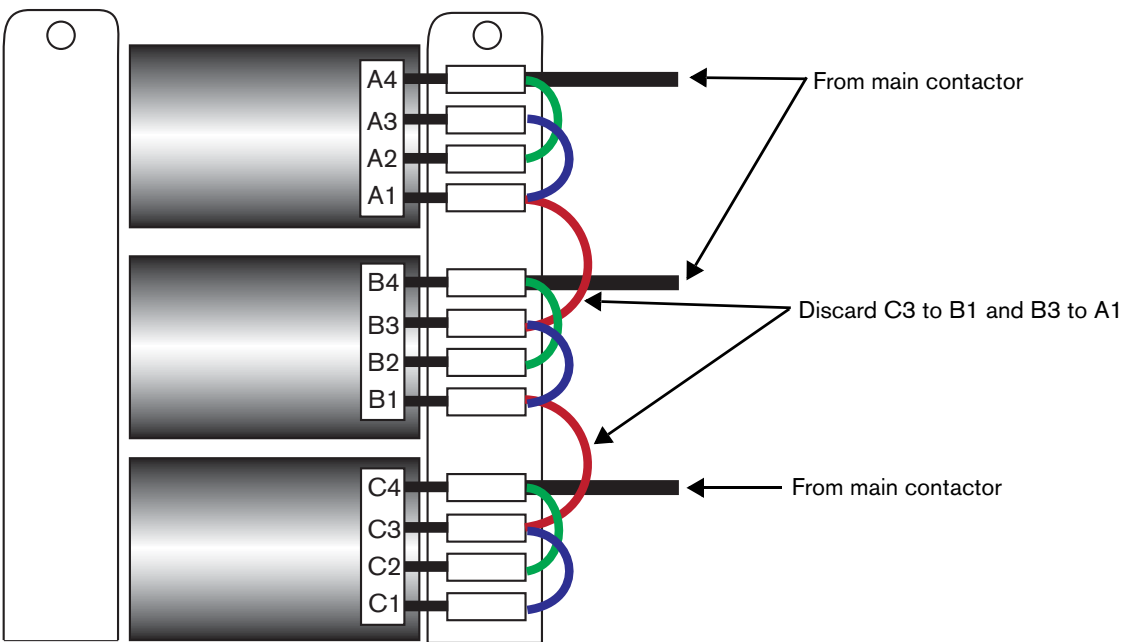

4. Reuse the wires that wire connect C1 to C3, C2 to C4, B1 to B3, B2 to B4, A1 to A3, and A2 to A4 and install them on the new transformer. See Figure 6.
 - ❑ Use 1 piece of 75 mm (3 inch) heatshrink tubing (104423) on C2, B2, and A2.
 - ❑ Use 2 pieces of 75 mm (3 inch) heatshrink tubing (104423) on each of these connection: C1, C3, B1, B3, A1, and A3.

HPR260 and HPR260XD Transformer Wiring

5. From the new wire group, use the two shorter wires to connect C4 to B1 and B4 to A1. See Figure 6.
6. Use the long wire to connect C1 to A4.
7. Assemble the triple wire connections C4, B4, and A4 using the three mounting screws (075728) provided in the kit. Cover each triple connection with one piece of 100 mm (4 inch) heatshrink (104450).

Figure 6

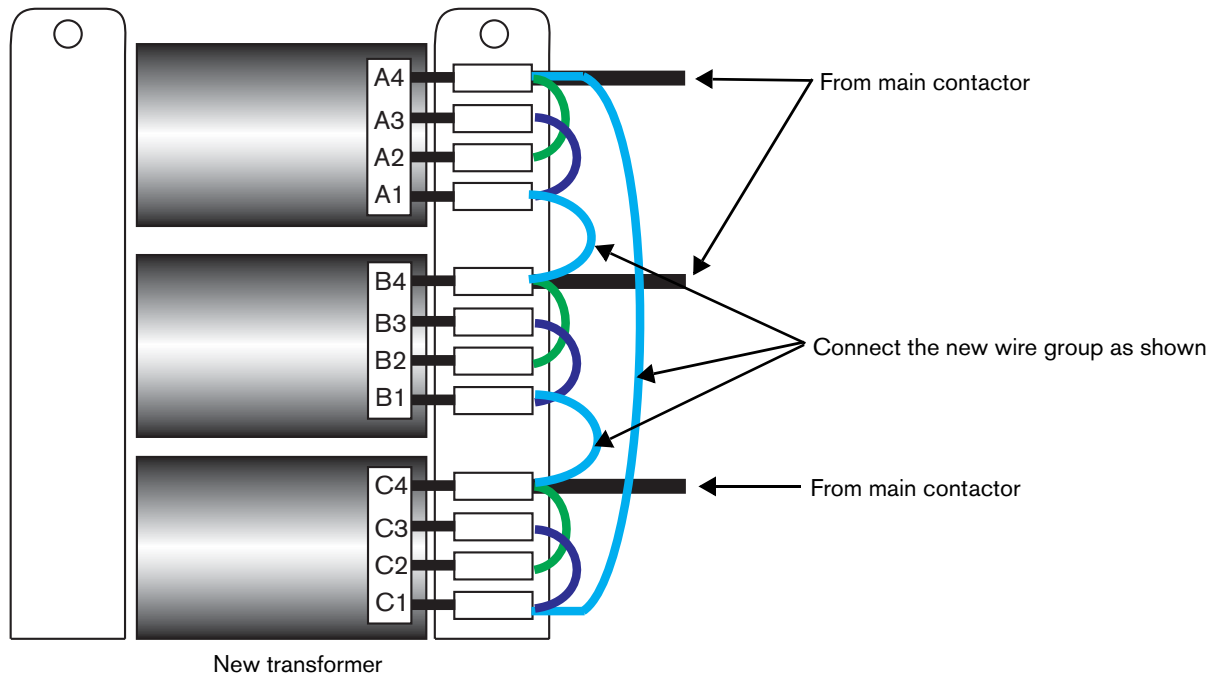

8. Use 6 of the remaining pieces of heatshrink tubing to insulate the secondary wire connections 1A, 2A, 1B, 2B, and 1C, 2C to the chopper. These connections are not shown in the illustration.

 HPR260XD 200 – 408 V plasma systems with serial number 005468 or higher use the wiring shown in Figure 6.