

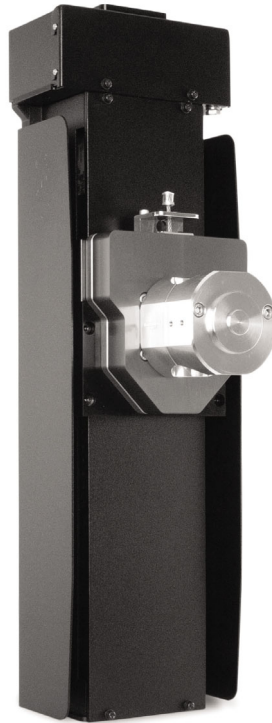

Sensor™ THC Plasma Lifter

Installation Manual



808970 – REVISION 3

ENGLISH

Register your new Hypertherm system

Benefits of registration

- Safety:** Registration allows us to contact you in the unlikely event a safety or quality notification is required.
- Education:** Registration gives you free access to online product training content via the Hypertherm Cutting Institute.
- Confirmation of ownership:** Registration can serve as proof of purchase in case of an insurance loss.

Go to www.hypertherm.com/registration for easy and fast registration.

If you experience any problems with the product registration process, please contact registration@hypertherm.com.

For your records

Serial number: _____

Purchase date: _____

Distributor: _____

Maintenance notes: _____

Sensor, Phoenix, EDGE, MicroEDGE, HPRXD, HPR130XD, HPR260XD, HPR400XD, and Hypertherm are trademarks of Hypertherm, Inc. and may be registered in the United States and other countries. All other trademarks are the property of their respective holders.

Environmental stewardship is one of Hypertherm's core values. www.hypertherm.com/environment

© 2016 – 2022 Hypertherm, Inc. 100% Associate-owned.

Sensor™ THC Plasma Lifter

Installation Manual

808970
REVISION 3

English
Original instructions

September 2022

Hypertherm, Inc.
Hanover, NH 03755 USA
www.hypertherm.com

Hypertherm, Inc.

21 Great Hollow Road, P.O. Box 5010
 Hanover, NH 03755 USA
 603-643-3441 Tel (Main Office)
 603-643-5352 Fax (All Departments)
 info@hypertherm.com (Main Office)

800-643-9878 Tel (Technical Service)

technical.service@hypertherm.com (Technical Service)

800-737-2978 Tel (Customer Service)

customer.service@hypertherm.com (Customer Service)

Hypertherm México, S.A. de C.V.

52 55 5681 8109 Tel
 52 55 5681 7978 Tel
 soporte.tecnico@hypertherm.com (Technical Service)

Hypertherm Plasmatechnik GmbH

Sophie-Scholl-Platz 5
 63452 Hanau
 Germany
 00 800 33 24 97 37 Tel
 00 800 49 73 73 29 Fax

31 (0) 165 596900 Tel (Technical Service)**00 800 4973 7843 Tel (Technical Service)**

technicalservice.emeia@hypertherm.com (Technical Service)

Hypertherm (Singapore) Pte Ltd.

Solaris @ Kallang 164
 164 Kallang Way #03-13
 Singapore 349248, Republic of Singapore
 65 6841 2489 Tel
 65 6841 2490 Fax
 marketing.asia@hypertherm.com (Marketing)
 techsupportapac@hypertherm.com (Technical Service)

Hypertherm Japan Ltd.

Level 9, Edobori Center Building
 2-1-1 Edobori, Nishi-ku
 Osaka 550-0002 Japan
 81 6 6225 1183 Tel
 81 6 6225 1184 Fax
 htjapan.info@hypertherm.com (Main Office)
 techsupportapac@hypertherm.com (Technical Service)

Hypertherm Europe B.V.

Laan van Kopenhagen 100
 3317 DM Dordrecht
 Nederland
 31 165 596907 Tel
 31 165 596901 Fax
 31 165 596908 Tel (Marketing)
31 (0) 165 596900 Tel (Technical Service)
00 800 4973 7843 Tel (Technical Service)
 technicalservice.emeia@hypertherm.com (Technical Service)

Hypertherm (Shanghai) Trading Co., Ltd.

B301, 495 ShangZhong Road
 Shanghai, 200231
 PR China
 86-21-80231122 Tel
 86-21-80231120 Fax

86-21-80231128 Tel (Technical Service)

techsupport.china@hypertherm.com (Technical Service)

South America & Central America: Hypertherm Brasil Ltda.

Rua Bras Cubas, 231 – Jardim Maia
 Guarulhos, SP – Brasil
 CEP 07115-030
 55 11 2409 2636 Tel
 tecnico.sa@hypertherm.com (Technical Service)

Hypertherm Korea Branch

#3904. APEC-ro 17. Heaundae-gu. Busan.
 Korea 48060
 82 (0)51 747 0358 Tel
 82 (0)51 701 0358 Fax
 marketing.korea@hypertherm.com (Marketing)
 techsupportapac@hypertherm.com (Technical Service)

Hypertherm Pty Limited

GPO Box 4836
 Sydney NSW 2001, Australia
 61 7 3103 1695 Tel
 61 7 3219 9010 Fax
 au.sales@hypertherm.com (Main Office)
 techsupportapac@hypertherm.com (Technical Service)

Hypertherm (India) Thermal Cutting Pvt. Ltd

A-18 / B-1 Extension,
 Mohan Co-Operative Industrial Estate,
 Mathura Road, New Delhi 110044, India
 91-11-40521201/ 2/ 3 Tel
 91-11 40521204 Fax
 htindia.info@hypertherm.com (Main Office)
 technicalservice.emeia@hypertherm.com (Technical Service)



For training and education resources, go to the Hypertherm Cutting Institute (HCI) online at www.hypertherm.com/hci.

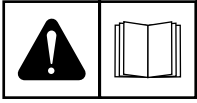

ENGLISH

WARNING! Before operating any Hypertherm equipment, read the safety instructions in your product's manual, the *Safety and Compliance Manual* (80669C), *Waterjet Safety and Compliance Manual* (80943C), and *Radio Frequency Warning Manual* (80945C). Failure to follow safety instructions can result in personal injury or in damage to equipment.

Copies of the manuals can come with the product in electronic and printed formats. Electronic copies are also on our website. Many manuals are available in multiple languages at www.hypertherm.com/docs.

BG (БЪЛГАРСКИ/BULGARIAN)

ПРЕДУПРЕЖДЕНИЕ! Преди да работите с което и да е оборудване Hypertherm, прочетете инструкциите за безопасност в ръководството на вашия продукт, „Инструкция за безопасност и съответствие“ (80669C), „Инструкция за безопасност и съответствие на Waterjet“ (80943C) и „Инструкция за предупреждение за радиочестота“ (80945C).

Продуктът може да е съпроводен от копия на ръководствата в електронен и в печатен формат. Тези в електронен формат са достъпни също на уебсайта ни. Много ръководства са налице на няколко езика на адрес www.hypertherm.com/docs.

CS (ČESKY/CZECH)

VAROVÁNÍ! Před uvedením jakéhokoli zařízení Hypertherm do provozu si přečtěte bezpečnostní pokyny v příručce k produktu a v *Manuálu pro bezpečnost a dodržování předpisů* (80669C), *Manuálu pro bezpečnost a dodržování předpisů při řezání vodním paprskem* (80943C) a *Manuálu varování ohledně rádiových frekvencí* (80945C).

Kopie příruček mohou být součástí dodávky produktu, a to v elektronické i tištěné formě. Elektronické kopie jsou k dispozici i na našich webových stránkách. Mnoho příruček je k dispozici v různých jazycích na stránce www.hypertherm.com/docs.

DA (DANSK/DANISH)

ADVARSEL! Inden Hypertherm udstyr tages i brug skal sikkerhedsinstruktionerne i produktets manual og i *Manual om sikkerhed og overholdelse af krav* (80669C), *Manual om sikkerhed og overholdelse af krav for vandstråleskæring* (80943C), og *Manual om radiofrekvensadvarsel* (80945C), gennemlæses.

Kopier af manualerne kan leveres med produktet i elektronisk og trykt format. Elektroniske kopier findes også på vores hjemmeside. Mange manualer er tilgængelige på flere sprog på www.hypertherm.com/docs.

DE (DEUTSCH/GERMAN)

WARNUNG! Bevor Sie ein Hypertherm-Gerät in Betrieb nehmen, lesen Sie bitte die Sicherheitsanweisungen in Ihrer Bedienungsanleitung, das *Handbuch für Sicherheit und Übereinstimmung* (80669C), das *Handbuch für Sicherheit und Compliance bei Wasserstrahl-Schneidanlagen* (80943C) und das *Handbuch für Hochfrequenz-Warnung* (80945C).

Bedienungsanleitungen und Handbücher können dem Gerät in elektronischer Form oder als Druckversion beiliegen. In elektronischer Form liegen sie auch auf unserer Website vor. Viele Handbücher stehen in verschiedenen Sprachen auf www.hypertherm.com/docs zur Verfügung.

ES (ESPAÑOL/SPANISH)

¡ADVERTENCIA! Antes de operar cualquier equipo Hypertherm, lea las instrucciones de seguridad del manual de su producto, del *Manual de seguridad y cumplimiento* (80669C), del *Manual de seguridad y cumplimiento en corte con chorro de agua* (80943C) y del *Manual de advertencias de radiofrecuencia* (80945C).

El producto puede incluir copias de los manuales en formato digital e impreso. Las copias digitales también están en nuestra página web. Hay diversos manuales disponibles en varios idiomas en www.hypertherm.com/docs.

ET (EESTI/ESTONIAN)

HOIATUS! Enne Hyperthermi mis tahes seadme kasutamist lugege läbi toote kasutusjuhendis olevad ohutusjuhised ning *Ohutus- ja vastavusjuhend* (80669C), *Veejõa ohutuse ja vastavuse juhend* (80943C) ja *Raadiosageduse hoiatusjuhend* (80945C). Ohutusjuhiste eiramine võib põhjustada vigastusi ja kahjustada seadmeid.

Juhiste koopiad võivad tootega kaasas olla elektrooniliselt või trükituna. Elektroonilised koopiad on saadaval ka meie veebilehel. Paljud kasutusjuhendid on erinevates keeltes saadaval veebilehel www.hypertherm.com/docs.

FI (SUOMI/FINNISH)

VAROITUS! Ennen minkään Hypertherm-laitteen käyttöä lue tuotteen käyttöoppaassa olevat turvallisuusohjeet, *turvallisuuden ja vaatimustenmukaisuuden käsikirja* (80669C), *vesileikkauksen turvallisuuden ja vaatimustenmukaisuuden käsikirja* (80943C) ja *radiotaajuusvaroitusten käsikirja* (80945C).

Käyttöoppaiden kopiot voivat olla tuotteen mukana sähköisessä ja tulostetussa muodossa. Sähköiset kopiot ovat myös verkkosivustollamme. Monet käyttöoppaat ovat myös saatavissa useilla kielillä www.hypertherm.com/docs.

FR (FRANÇAIS/FRENCH)

AVERTISSEMENT! Avant d'utiliser tout équipement Hypertherm, lire les consignes de sécurité du manuel de votre produit, du *Manuel de sécurité et de conformité* (80669C), du *Manuel de sécurité et de conformité du jet d'eau* (80943C) et du *Manuel d'avertissement relatif aux radiofréquences* (80945C).

Les exemplaires des manuels qui accompagnent le produit peuvent être sous forme électronique ou papier. Les manuels sous forme électronique se trouvent également sur notre site Internet. Plusieurs manuels sont offerts en plusieurs langues à www.hypertherm.com/docs.

GR (ΕΛΛΗΝΙΚΑ/GREEK)

ΠΡΟΕΙΔΟΠΟΙΗΣΗ! Πριν θέσετε σε λειτουργία οποιονδήποτε εξοπλισμό της Hypertherm, διαβάστε τις οδηγίες ασφαλείας στο εγχειρίδιο του προϊόντος και στο *εγχειρίδιο ασφαλείας και συμμόρφωσης* (80669C), στο *εγχειρίδιο ασφαλείας και συμμόρφωσης του waterjet* (80943C) και στο *εγχειρίδιο προειδοποιήσεων για τις ραδιοσυχνότητες* (80945C).

Το προϊόν μπορεί να συνοδεύεται από αντίγραφα των εγχειριδίων σε ηλεκτρονική και έντυπη μορφή. Τα ηλεκτρονικά αντίγραφα υπάρχουν επίσης στον ιστότοπό μας. Πολλά εγχειρίδια είναι διαθέσιμα σε διάφορες γλώσσες στο www.hypertherm.com/docs.

HU (MAGYAR/HUNGARIAN)

VIGYÁZAT! Mielőtt bármilyen Hypertherm berendezést üzemeltetne, olvassa el a biztonsági információkat a termék kézikönyvében, a *Biztonsági és szabálykövetési kézikönyvben* (80669C), a *Vízugaras biztonsági és szabálykövetési kézikönyvben* (80943C) és a *Rádiófrekvenciás figyelmeztetéseket tartalmazó kézikönyvben* (80945C).

A termékhez a kézikönyv példányai elektronikus és nyomtatott formában is mellékelve lehetnek. Az elektronikus példányok webhelyünkön is megtalálhatók. Számos kézikönyv áll rendelkezésre több nyelven a www.hypertherm.com/docs weboldalon.

ID (BAHASA INDONESIA/INDONESIAN)

PERINGATAN! Sebelum mengoperasikan peralatan Hypertherm, bacalah petunjuk keselamatan dalam manual produk Anda, *Manual Keselamatan dan Kepatuhan* (80669C), *Manual Keselamatan dan Kepatuhan Jet Air* (80943C), dan *Manual Peringatan Frekuensi Radio* (80945C). Kegagalan mengikuti petunjuk keselamatan dapat menyebabkan cedera pribadi atau kerusakan pada peralatan.

Produk mungkin disertai salinan manual atau petunjuk dalam format elektronik maupun cetak. Salinan elektronik juga tersedia di situs web kami. Berbagai manual tersedia dalam beberapa bahasa di www.hypertherm.com/docs.

IT (ITALIANO/ITALIAN)

AVVERTENZA! Prima di usare un'attrezzatura Hypertherm, leggere le istruzioni sulla sicurezza nel manuale del prodotto, nel *Manuale sulla sicurezza e la conformità* (80669C), nel *Manuale sulla sicurezza e la conformità Waterjet* (80943C) e nel *Manuale di avvertenze sulla radiofrequenza* (80945C).

Copie del manuale possono accompagnare il prodotto in formato cartaceo o elettronico. Le copie elettroniche sono disponibili anche sul nostro sito web. Molti manuali sono disponibili in diverse lingue all'indirizzo www.hypertherm.com/docs.

JA (日本語/JAPANESE)

警告! Hypertherm 機器を操作する前に、この製品説明書にある安全情報、「安全とコンプライアンスマニュアル」(80669C)、「ウォータージェット的安全とコンプライアンス」(80943C)、「高周波警告」(80945C)をお読みください。

説明書のコピーは、電子フォーマット、または印刷物として製品に同梱されています。電子コピーは当社ウェブサイトにも掲載されています。説明書の多くは www.hypertherm.com/docs にて複数の言語でご用意しています。

KO (한국어/KOREAN)

경고! Hypertherm 장비를 사용하기 전에 제품 설명서와 안전 및 규정 준수 설명서(80669C), 워터젯 안전 및 규정 준수 설명서(80943C) 그리고 무선 주파수 경고 설명서(80945C)에 나와 있는 안전 지침을 읽으십시오.

전자 형식과 인쇄된 형식으로 설명서 사본이 제품과 함께 제공될 수 있습니다. 전자 사본도 Hypertherm 웹사이트에서 보실 수 있으며 설명서 사본은 www.hypertherm.com/docs 에서 여러 언어로 제공됩니다.

NE (NEDERLANDS/DUTCH)

WAARSCHUWING! Lees voordat u Hypertherm-apparaat gebruikt de veiligheidsinstructies in de producthandleiding, in de *Veiligheids- en nalevingshandleiding* (80669C) in de *Veiligheids- en nalevingshandleiding voor waterstralen* (80943C) en in de *Waarschuwingshandleiding radiofrequentie* (80945C).

De handleidingen kunnen in elektronische en gedrukte vorm met het product worden meegeleverd. Elektronische versies zijn ook beschikbaar op onze website. Veel handleidingen zijn in meerdere talen beschikbaar via www.hypertherm.com/docs.

NO (NORSK/NORWEGIAN)

ADVARSEL! Før du bruker noe Hypertherm-utstyr, må du lese sikkerhetsinstruksjonene i produktets håndbok, *håndboken om sikkerhet og samsvar* (80669C), *håndboken om vannjet sikkerhet og samsvar* (80943C), og *håndboken om radiofrekvensadvarslar* (80945C).

Eksemplarer av håndbøkene kan følge med produktet i elektronisk og trykt form. Elektroniske eksemplarer finnes også på nettstedet vårt. Mange håndbøker er tilgjengelig i flere språk på www.hypertherm.com/docs.

PL (POLSKI/POLISH)

OSTRZEŻENIE! Przed rozpoczęciem obsługi jakiegokolwiek systemu firmy Hypertherm należy się zapoznać z instrukcjami bezpieczeństwa zamieszczonymi w podręczniku produktu, w *podręczniku bezpieczeństwa i zgodności* (80669C), *podręczniku bezpieczeństwa i zgodności systemów strumienia wody* (80943C) oraz *podręczniku z ostrzeżeniem o częstotliwości radiowej* (80945C).

Do produktu mogą być dołączone podręczniki użytkownika w formie elektronicznej i drukowanej. Kopie elektroniczne znajdują się również w naszej witrynie internetowej. Wiele podręczników jest dostępnych w różnych językach pod adresem www.hypertherm.com/docs.

PT (PORTUGUÊS/PORTUGUESE)

ADVERTÊNCIA! Antes de operar qualquer equipamento Hypertherm, leia as instruções de segurança no manual do seu produto, no *Manual de Segurança e de Conformidade* (80669C), no *Manual de Segurança e de Conformidade do Waterjet* (80943C) e no *Manual de Advertência de radiofrequência* (80945C).

Cópias dos manuais podem vir com o produto nos formatos eletrônico e impresso. Cópias eletrônicas também são encontradas em nosso website. Muitos manuais estão disponíveis em vários idiomas em www.hypertherm.com/docs.

RO (ROMÂNĂ/ROMANIAN)

AVERTIZARE! Înainte de utilizarea oricărui echipament Hypertherm, citiți instrucțiunile de siguranță din manualul produsului, *manualul de siguranță și conformitate* (80669C), *manualul de siguranță și conformitate Waterjet* (80943C) și din *manualul de avertizare privind radiofrecvența* (80945C).

Produsul poate fi însoțit de copii ale manualelor în format tipărit și electronic. Exemplarele electronice sunt disponibile și pe site-ul nostru web. Numeroase manuale sunt disponibile în mai mult limbi la adresa: www.hypertherm.com/docs.

RU (РУССКИЙ/RUSSIAN)

БЕРЕГИТЬСЯ! Перед работой с любым оборудованием Hypertherm ознакомьтесь с инструкциями по безопасности, представленными в руководстве, которое поставляется вместе с продуктом, в *Руководстве по безопасности и соответствию* (80669C), в *Руководстве по безопасности и соответствию для водоструйной резки* (80943C) и *Руководстве по предупреждению о радиочастотном излучении* (80945C).

Копии руководств, которые поставляются вместе с продуктом, могут быть представлены в электронном и бумажном виде. Электронные копии также доступны на нашем веб-сайте. Целый ряд руководств доступны на нескольких языках по ссылке www.hypertherm.com/docs.

SK (SLOVENČINA/SLOVAK)

VÝSTRAHA! Pred použitím akéhokoľvek zariadenia od spoločnosti Hypertherm si prečítajte bezpečnostné pokyny v návode na obsluhu vášho zariadenia a v *Manuáli o bezpečnosti a súlade s normami* (80669C), *Manuáli o bezpečnosti a súlade s normami pre systém rezania vodou* (80943C) a v *Manuáli s informáciami o rádiových frekvenciách* (80945C).

Návod na obsluhu sa dodáva spolu s produktom v elektronickej a tlačenej podobe. Jeho elektronickej formát je dostupný aj na našej webovej stránke. Mnohé z návodov na obsluhu sú dostupné vo viacjazyčnej mutácii na stránke www.hypertherm.com/docs.

SL (SLOVENŠČINA/SLOVENIAN)

OPOZORILO! Pred uporabo katerekoli Hyperthermove opreme preberite varnostna navodila v priročniku vašega izdelka, v *Priročniku za varnost in skladnost* (80669C), v *Priročniku za varnost in skladnost sistemov rezanja z vodnim curkom* (80943C) in v *Priročniku Opozorilo o radijskih frekvencah* (80945C).

Izvodi priročnikov so lahko izdelku priloženi v elektronski in tiskani obliki. Elektronski izvodi so na voljo tudi na našem spletnem mestu. Številni priročniki so na voljo v različnih jezikih na naslovu www.hypertherm.com/docs.

SR (SRPSKI/SERBIAN)

UPOZORENJE! Pre rukovanja bilo kojom Hyperthermovom opremom pročitajte uputstva o bezbednosti u svom priručniku za proizvod, *Priručniku o bezbednosti i usaglašenosti* (80669C), *Priručniku o bezbednosti i usaglašenosti Waterjet tehnologije* (80943C) i *Priručniku sa upozorenjem o radio-frekvenciji* (80945C).

Уз производ се испоручују копије приручника у електронском или штампаном формату. Електронске копије су такође доступне на нашем веб-сајту. Многи приручници су доступни на више језика на адреси www.hypertherm.com/docs.

SV (SVENSKA/SWEDISH)

VARNING! Läs häftet säkerhetsinformationen i din produkts *säkerhets- och efterlevnadsmanual* (80669C), *säkerhets- och efterlevnadsmanualen för Waterjet* (80943C) och *varningsmanualen för radiofrekvenser* (80945C) för viktig säkerhetsinformation innan du använder eller underhåller Hypertherm-utrustning.

Kopior av manualerna kan medfölja produkten i elektroniskt och tryckt format. Elektroniska kopior finns också på vår webbplats. Många manualer finns på flera språk på www.hypertherm.com/docs.

TH (ภาษาไทย/THAI)

คำเตือน! ก่อนการใช้งานอุปกรณ์ของ Hypertherm ทั้งหมด โปรดอ่านคำแนะนำด้านความปลอดภัยในคู่มือการใช้สินค้า คู่มือด้านความปลอดภัยและการปฏิบัติตาม (80669C), คู่มือด้านความปลอดภัยและการปฏิบัติตามสำหรับการใช้หัวตัดระบบวอเตอร์เจ็ต (80943C) และ คู่มือคำเตือนเกี่ยวกับความถี่วิทยุ (80945C) การไม่ปฏิบัติตามคำแนะนำด้านความปลอดภัยอาจส่งผลให้เกิดการบาดเจ็บหรือเกิดความเสียหายต่ออุปกรณ์

สำเนาคู่มือทั้งในรูปแบบอิเล็กทรอนิกส์และแบบสิ่งพิมพ์จะถูกแนบมาพร้อมกับผลิตภัณฑ์ สำหรับสำเนาคู่มือในรูปแบบอิเล็กทรอนิกส์ของผลิตภัณฑ์และสำเนาคู่มือต่างๆ ในหลากหลายภาษายังมีให้บริการบนเว็บไซต์ www.hypertherm.com/docs ของเรอีกด้วย

TR (TÜRKÇE/TURKISH)

UYARI! Bir Hypertherm ekipmanını çalıştırmadan önce, ürününüzün kullanım kılavuzunda, *Güvenlik ve Uyumluluk Kılavuzu'nda* (80669C), *Su Jeti Güvenlik ve Uyumluluk Kılavuzu'nda* (80943C) ve *Radyo Frekansı Uyarısı Kılavuzu'nda* (80945C) yer alan güvenlik talimatlarını okuyun.

Kılavuzların kopyaları, elektronik ve basılı formatta ürünle birlikte verilebilir. Elektronik kopyalar web sitemizde de yer alır. Kılavuzların birçokğu www.hypertherm.com/docs adresinde birçok dilde mevcuttur.

VI (TIẾNG VIỆT/VIETNAMESE)

CẢNH BÁO! Trước khi vận hành bất kỳ thiết bị Hypertherm nào, hãy đọc các hướng dẫn an toàn trong hướng dẫn sử dụng sản phẩm của bạn, *Sổ tay An toàn và Tuân thủ* (80669C), *Sổ tay An toàn và Tuân thủ Tia nước* (80943C), và *Hướng dẫn Cảnh báo Tần số Vô tuyến* (80945C). Không tuân thủ các hướng dẫn an toàn có thể dẫn đến thương tích cá nhân hoặc hư hỏng thiết bị.

Bản sao của sổ tay có thể đi kèm với sản phẩm ở định dạng điện tử và in. Bản điện tử cũng có trên trang web của chúng tôi. Nhiều sổ tay có sẵn bằng nhiều ngôn ngữ tại www.hypertherm.com/docs.

ZH-CN (简体中文/CHINESE SIMPLIFIED)

警告! 在操作任何海宝设备之前, 请阅读产品手册、《安全和法规遵守手册》(80669C)、《水射流安全和法规遵守手册》(80943C) 以及《射频警告手册》(80945C) 中的安全操作说明。

随产品提供的手册可提供电子版和印刷版两种格式。电子版本同时也在我们的网站上提供。很多手册有多种语言版本, 详见 www.hypertherm.com/docs。

ZH-TW (繁體中文/CHINESE TRADITIONAL)

警告! 在操作任何 Hypertherm 設備前, 請先閱讀您產品手冊內的安全指示, 包括《安全和法規遵從手冊》(80669C)、《水刀安全和法規遵從手冊》(80943C), 以及《無線電頻率警示訊號手冊》(80945C)。

電子版和印刷版手冊複本可能隨產品附上。您也可以前往我們的網站下載電子版手冊。我們的網站上還以多種語言形式提供多種手冊, 請造訪 www.hypertherm.com/docs。

Contents

Safety	SC-9
Product Stewardship.....	SC-17
Environmental Stewardship	SC-19
Electromagnetic Compatibility (EMC)	SC-21
Warranty.....	SC-23
1 Overview	25
2 Specifications and parts	27
Upon receipt.....	27
Claims.....	27
Sensor THC Plasma Lifter.....	28
Data plate.....	30
Lifter interface cable	31
Motors and drives.....	31
Motor couplings	33

Replacement parts	34
Lifter parts.....	34
Breakaway parts.....	36
Wiring diagram	36
3 Install	39
Install the motor.....	39
Move the connector for the lifter interface cable (optional).....	41
Install the lifter.....	43
Ground the lifter.....	45
Install the THC drive.....	45
Install voltage divider board/VDC3.....	45
4 Connect	47
Connect the lifter to the THC drive.....	47
Connect the THC drive to the network.....	49
Connect the VDC3 board.....	49



RECOGNIZE SAFETY INFORMATION

The symbols shown in this section are used to identify potential hazards. When you see a safety symbol in this manual or on your machine, understand the potential for personal injury, and follow the related instructions to avoid the hazard.



FOLLOW SAFETY INSTRUCTIONS

Carefully read all safety messages in this manual and safety labels on your machine.

- Keep the safety labels on your machine in good condition. Replace missing or damaged labels immediately.
- Learn how to operate the machine and how to use the controls properly. Do not let anyone operate it without instruction.
- Keep your machine in proper working condition. Unauthorized modifications to the machine may affect safety and machine service life.

DANGER WARNING CAUTION

American National Standards Institute (ANSI) guidelines are used for safety signal words and symbols. The signal word DANGER or WARNING is used with a safety symbol. DANGER identifies the most serious hazards.

- DANGER and WARNING safety labels are located on your machine near specific hazards.
- DANGER safety messages precede related instructions in the manual that will result in serious injury or death if not followed correctly.
- WARNING safety messages precede related instructions in this manual that may result in injury or death if not followed correctly.
- CAUTION safety messages precede related instructions in this manual that may result in minor injury or damage to equipment if not followed correctly.

INSPECT EQUIPMENT BEFORE USING

All cutting equipment must be inspected as required to make sure it is in safe operating condition. When found to be incapable of reliable and safe operation, the equipment must be repaired by qualified personnel prior to its next use or withdrawn from service.

RESPONSIBILITY FOR SAFETY

The person or entity responsible for the safety of the workplace must:

- Make sure that operators and their supervisors are trained in the safe use of their equipment, the safe use of the process, and emergency procedures.
- Make sure that all hazards and safety precautions identified herein are communicated to and understood by workers before the start of work.
- Designate approved cutting areas and establish procedures for safe cutting.
- Be responsible for authorizing cutting operations in areas not specifically designed or approved for such processes.
- Make sure that only approved equipment, such as torches and personal protective equipment, are used.
- Select contractors who provide trained and qualified personnel, and who have awareness of the risks involved, to do cutting.
- Tell contractors about flammable materials or hazardous conditions that are specific to the site, or hazardous conditions that they may not be aware of.
- Make sure that the quality and quantity of air for ventilation is such that personnel exposures to hazardous contaminants are below the allowable limits.
- Make sure that ventilation in confined spaces is sufficient to allow adequate oxygen for life support, to prevent accumulation of asphyxiants or flammable explosive mixtures, to prevent oxygen-enriched atmospheres, and to keep airborne contaminants in breathing atmospheres below allowable limits.



A PLASMA ARC CAN DAMAGE FROZEN PIPES

Frozen pipes may be damaged or can burst if you attempt to thaw them with a plasma torch.



STATIC ELECTRICITY CAN DAMAGE PRINTED CIRCUIT BOARDS

Use proper precautions when handling printed circuit boards:

- Store printed circuit boards in anti-static containers.
- Wear a grounded wrist strap when handling printed circuit boards.



GROUNDING SAFETY

Work lead Attach the work lead securely to the workpiece or the cutting table with good metal-to-metal contact. Do not connect it to the piece that will fall away when the cut is complete.

Cutting table Connect the cutting table to an earth ground, in accordance with appropriate national and local electrical regulations.

Input power

- Make sure to connect the power cord ground wire to the ground in the disconnect box.
- If installation of the plasma system involves connecting the power cord to the power supply, make sure to connect the power cord ground wire properly.
- Place the power cord's ground wire on the stud first, then place any other ground wires on top of the power cord ground. Tighten the retaining nut.
- Tighten all electrical connections to avoid excessive heating.

ELECTRICAL HAZARDS

- Only trained and authorized personnel may open this equipment.
- If the equipment is permanently connected, turn it off, and lock out/tag out power before the enclosure is opened.
- If power is supplied to the equipment with a cord, unplug the unit before the enclosure is opened.
- Lockable disconnects or lockable plug covers must be provided by others.
- Wait 5 minutes after removal of power before entering the enclosure to allow stored energy to discharge.
- If the equipment must have power when the enclosure is open for servicing, arc flash explosion hazards may exist. Follow **all** local requirements (NFPA 70E in the USA) for safe work practices and for personal protective equipment when servicing energized equipment.
- Prior to operating the equipment after moving, opening, or servicing, make sure to close the enclosure and make sure that there is proper earth ground continuity to the enclosure.
- Always follow these instructions for disconnecting power before inspecting or changing torch consumable parts.



ELECTRIC SHOCK CAN KILL

Touching live electrical parts can cause a fatal shock or severe burn.

- Operating the plasma system completes an electrical circuit between the torch and the workpiece. The workpiece and anything touching the workpiece are part of the electrical circuit.
- In machine torch applications, never touch the torch body, workpiece, or water in a water table when the plasma system is operating.

Electric shock prevention

All plasma systems use high voltage in the cutting process (200 to 400 VDC are common). Take the following precautions when operating this system:

- Wear insulated gloves and boots, and keep your body and clothing dry.
- Do not stand, sit, or lie on – or touch – any wet surface when using the plasma system.
- Insulate yourself from the work and ground using dry insulating mats or covers big enough to prevent any physical contact with the work or ground. If you must cut in or near a damp area, use extreme caution.
- Provide a disconnect switch close to the power supply with properly sized fuses. This switch allows the operator to turn off the power supply quickly in an emergency situation.
- When using a water table, make sure that it is correctly connected to an earth ground.

- Install and ground this equipment according to the instruction manual and in accordance with national and local regulations.
- Inspect the input power cord frequently for damage or cracking of the cover. Replace a damaged power cord immediately.
Bare wiring can kill.
- Inspect and replace any worn or damaged torch leads.
- Do not pick up the workpiece, including the waste cutoff, while you cut. Leave the workpiece in place or on the workbench with the work lead attached during the cutting process.
- Before checking, cleaning, or changing torch parts, disconnect the main power or unplug the power supply.
- Never bypass or shortcut the safety interlocks.
- Before removing any power supply or system enclosure cover, disconnect electrical input power. Wait 5 minutes after disconnecting the main power to allow capacitors to discharge.
- Never operate the plasma system unless the power supply covers are in place. Exposed power supply connections present a severe electrical hazard.
- When making input connections, attach a proper grounding conductor first.
- Each plasma system is designed to be used only with specific torches. Do not substitute other torches, which could overheat and present a safety hazard.



CUTTING CAN CAUSE FIRE OR EXPLOSION

Fire prevention

- Make sure the cutting area is safe before doing any cutting. Keep a fire extinguisher nearby.
- Remove all flammables within 35 feet (10 m) of the cutting area.
- Quench hot metal or allow it to cool before handling or before letting it touch combustible materials.
- Never cut containers with potentially flammable materials inside – they must be emptied and properly cleaned first.
- Ventilate potentially flammable atmospheres before cutting.
- When cutting with oxygen as the plasma gas, an exhaust ventilation system is required.

Explosion prevention

- Do not use the plasma system if explosive dust or vapors may be present.
- Do not cut pressurized cylinders, pipes, or any closed containers.
- Do not cut containers that have held combustible materials.



WARNING

Explosion Hazard

Hydrogen Detonation with Aluminum Cutting

When you use a plasma torch to cut aluminum alloys under water or on a water table, a chemical reaction between the water and the workpiece, parts, fine particles, or molten aluminum droplets generates significantly more hydrogen gas than occurs with other metals. This hydrogen gas may get trapped under the workpiece. If exposed to oxygen or air, the plasma arc or a spark from any source can ignite this trapped hydrogen gas, causing an explosion that may result in death, personal injury, loss of property, or equipment damage.

Consult with the table manufacturer and other experts prior to cutting aluminum to implement a risk assessment and mitigation plan that eliminates the risk of detonation by preventing hydrogen accumulation.



WARNING

Explosion Hazard
Argon-Hydrogen and Methane

Hydrogen and methane are flammable gases that present an explosion hazard. Keep flames away from cylinders and hoses that contain methane or hydrogen mixtures. Keep flames and sparks away from the torch when using methane or argon-hydrogen plasma.



WARNING

Explosion Hazard
Underwater Cutting with Fuel Gases
Containing Hydrogen

- Do not cut underwater with fuel gases containing hydrogen.
- Cutting underwater with fuel gases containing hydrogen can result in an explosive condition that can detonate during plasma cutting operations.



Also, make sure that the water table, fume extraction (ventilation), and other parts of the cutting system have been designed with aluminum cutting in mind.

Do not cut aluminum alloys underwater or on a water table unless you can prevent the accumulation of hydrogen gas.

Note: With proper mitigation, most aluminum alloys can be plasma cut on a water table. An exception is aluminum-lithium alloys. **Never cut aluminum-lithium alloys in the presence of water.** Contact your aluminum supplier for additional safety information regarding hazards associated with aluminum-lithium alloys.



MACHINE MOTION CAN CAUSE INJURY

When an original equipment manufacturer (OEM) makes a cutting system by combining Hypertherm equipment with other equipment, the end-use customer and the OEM are responsible for providing protection against the hazardous moving parts of this cutting system. However, we advise the following to prevent operator injury and equipment damage:

- Read and follow the instruction manual provided by the OEM.
- Maintain a restricted-access area larger than the maximum movement range of the cutting system's moving parts.
- Where there is a risk of collision, do not allow personnel or equipment near the cutting system's moving parts.
- Avoid accidental contact with the CNC touchscreen or joystick. Accidental contact can activate commands and result in unintended motion.
- Do not service or clean the machinery during operation.
- If servicing is required, enable the safety interlock or disconnect and lock out/tag out power to disable the motors and prevent motion.
- Allow only qualified personnel to operate, maintain, and service the machinery.

COMPRESSED GAS EQUIPMENT SAFETY

- Never lubricate cylinder valves or regulators with oil or grease.
- Use only correct gas cylinders, regulators, hoses, and fittings designed for the specific application.
- Maintain all compressed gas equipment and associated parts in good condition.
- Label and color-code all gas hoses to identify the type of gas in each hose. Consult applicable national and local regulations.

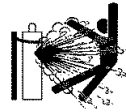

GAS CYLINDERS CAN EXPLODE IF DAMAGED

Gas cylinders contain gas under high pressure. If damaged, a cylinder can explode.

- Handle and use compressed gas cylinders in accordance with applicable national and local regulations.
- Never use a cylinder that is not upright and secured in place.
- Keep the protective cap in place over the valve except when the cylinder is in use or connected for use.
- Never allow electrical contact between the plasma arc and a cylinder.
- Never expose cylinders to excessive heat, sparks, slag, or open flame.
- Never use a hammer, wrench, or other tool to open a stuck cylinder valve.



TOXIC FUMES CAN CAUSE INJURY OR DEATH

The plasma arc by itself is the heat source used for cutting. Accordingly, although the plasma arc has not been identified as a source of toxic fumes, the material being cut can be a source of toxic fumes or gases that deplete oxygen.

The fumes produced vary depending on the metal that is cut. Metals that may release toxic fumes include, but are not limited to, stainless steel, carbon steel, zinc (galvanized), and copper.

In some cases, the metal may be coated with a substance that could release toxic fumes. Toxic coatings include, but are not limited to, lead (in some paints), cadmium (in some paints and fillers), and beryllium.

The gases produced by plasma cutting vary based on the material to be cut and the method of cutting, but may include ozone, oxides of nitrogen, hexavalent chromium, hydrogen, and other substances if such are contained in or released by the material being cut.

Caution should be taken to minimize exposure to fumes produced by any industrial process. Depending on the chemical composition and concentration of the fumes (as well as other factors, such as ventilation), there may be a risk of physical illness, such as birth defects or cancer.

It is the responsibility of the equipment and site owner to test the air quality in the cutting area and to make sure that the air quality in the workplace meets all local and national standards and regulations.

The air quality level in any relevant workplace depends on site-specific variables such as:

- Table design (wet, dry, underwater).
- Material composition, surface finish, and composition of coatings.
- Volume of material removed.
- Duration of cutting or gouging.
- Size, air volume, ventilation, and filtration of the workplace.
- Personal protective equipment.
- Number of welding and cutting systems in operation.
- Other workplace processes that may produce fumes.

If the workplace must conform to national or local regulations, only monitoring or testing done at the site can determine whether the workplace is above or below allowable levels.

To reduce the risk of exposure to fumes:

- Remove all coatings and solvents from the metal before cutting.
- Use local exhaust ventilation to remove fumes from the air.
- Do not inhale fumes. Wear an air-supplied respirator when cutting any metal coated with, containing, or suspected to contain toxic elements.
- Make sure that those using welding or cutting equipment, as well as air-supplied respiration devices, are qualified and trained in the proper use of such equipment.
- Never cut containers with potentially toxic materials inside. Empty and properly clean the container first.
- Monitor or test the air quality at the site as needed.
- Consult with a local expert to implement a site plan to make sure air quality is safe.



A PLASMA ARC CAN CAUSE INJURY AND BURNS

Instant-on torches

A plasma arc ignites immediately when the torch switch is activated.

The plasma arc will cut quickly through gloves and skin.

- Keep away from the torch tip.
- Do not hold metal near the cutting path.
- Never point the torch toward yourself or others.



ARC RAYS CAN BURN EYES AND SKIN

Eye protection Plasma arc rays produce intense visible and invisible (ultraviolet and infrared) rays that can burn eyes and skin.

- Use eye protection in accordance with applicable national and local regulations.
- Wear eye protection (safety glasses or goggles with side shields, and a welding helmet) with appropriate lens shading to protect your eyes from the arc's ultraviolet and infrared rays.

Skin protection Wear protective clothing to protect against burns caused by ultraviolet light, sparks, and hot metal.

- Wear gauntlet gloves, safety shoes, and hat.

- Wear flame-retardant clothing to cover all exposed areas.
- Wear cuffless trousers to prevent entry of sparks and slag.

Also, remove any combustibles, such as a butane lighter or matches, from your pockets before cutting.

Cutting area Prepare the cutting area to reduce reflection and transmission of ultraviolet light:

- Paint walls and other surfaces with dark colors to reduce reflection.
- Use protective screens or barriers to protect others from flash and glare.
- Warn others not to watch the arc. Use placards or signs.

Arc current	Minimum protective shade number (ANSI Z49.1:2012)	Suggested shade number for comfort (ANSI Z49.1:2012)	OSHA 29CFR 1910.133(a)(5)	Europe EN168:2002
Less than 40 A	5	5	8	9
41 A to 60 A	6	6	8	9
61 A to 80 A	8	8	8	9
81 A to 125 A	8	9	8	9
126 A to 150 A	8	9	8	10
151 A to 175 A	8	9	8	11
176 A to 250 A	8	9	8	12
251 A to 300 A	8	9	8	13
301 A to 400 A	9	12	9	13
401 A to 800 A	10	14	10	N/A



PACEMAKER AND HEARING AID OPERATION

Pacemaker and hearing aid operation can be affected by magnetic fields from high currents.

Pacemaker and hearing aid wearers should consult a doctor before going near any plasma arc cutting and gouging operations.

To reduce magnetic field hazards:

- Keep both the work lead and the torch lead to one side, away from your body.
- Route the torch leads as close as possible to the work lead.
- Do not wrap or drape the torch lead or work lead around your body.
- Keep as far away from the power supply as possible.



NOISE CAN DAMAGE HEARING

Cutting with a plasma arc can exceed acceptable noise levels as defined by local regulations in many applications. Prolonged exposure to excessive noise can damage hearing. Always wear proper ear protection when cutting or gouging, unless sound pressure level measurements taken at the site have verified personal hearing protection is not necessary per relevant international, regional, and local regulations.

Significant noise reduction can be obtained by adding simple engineering controls to cutting tables such as barriers or curtains positioned between the plasma arc and the workstation, and/or locating the workstation away from the plasma arc. Implement administrative controls in the workplace to restrict access and limit operator exposure time, and screen off noisy areas and/or take measures to reduce reverberation in cutting areas by putting up noise absorbers.

Use ear protectors if the noise is disruptive or if there is a risk of hearing damage after all other engineering and administrative controls have been implemented. If hearing protection is required, wear only approved personal protective equipment such as ear muffs or ear plugs with a noise reduction rating appropriate for the situation. Warn others near the cutting area of possible noise hazards. In addition, ear protection can prevent hot splatter from entering the ear.

DRY DUST COLLECTION INFORMATION

In some workplaces, dry dust can represent a potential explosion hazard.

The U.S. National Fire Protection Association's NFPA standard 68, "Explosion Protection by Deflagration Venting," provides requirements for the design, location, installation, maintenance, and use of devices and systems to vent combustion gases and pressures after any deflagration event. Consult with the manufacturer or installer of any dry dust collection system for applicable requirements before you install a new dry dust collection system or make significant changes in the process or materials used with an existing dry dust collection system.

Consult your local "Authority Having Jurisdiction" (AHJ) to determine whether any edition of NFPA standard 68 has been "adopted by reference" in your local building codes.

Refer to NFPA standard 68 for definitions and explanations of regulatory terms such as deflagration, AHJ, adopted by reference, the Kst value, deflagration index, and other terms.

Note 1 – Unless a site-specific evaluation has been completed that determines that none of the dust generated is combustible, then NFPA standard 68 requires the use of explosion vents. Design the explosion vent size and type to conform to the worst-case Kst value as described in Annex F of NFPA standard 68. NFPA standard 68 does not specifically identify plasma cutting or other thermal cutting processes as requiring deflagration venting systems, but it does apply these new requirements to all dry dust collection systems.

Note 2 – Users should consult and comply with all applicable national, state, and local regulations. Publications do not intend to urge action that is not in compliance with all applicable regulations and standards, and this manual may never be construed as doing so.

LASER RADIATION

Exposure to the laser beam from a laser pointer can result in serious eye injury. Avoid direct eye exposure.

On products that use a laser pointer for alignment, one of the following laser radiation labels has been applied on the product near where the laser beam exits the enclosure. The maximum output (mV), wavelength emitted (nM), and, if appropriate, pulse duration are also provided.

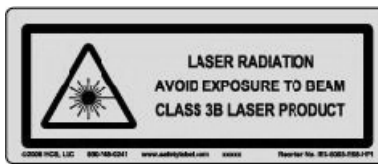

Additional laser safety instructions:

- Consult with an expert on local laser regulations. Laser safety training may be required.
- Do not allow untrained persons to operate the laser. Lasers can be dangerous in the hands of untrained users.
- Do not look into the laser aperture or beam at any time.
- Position the laser as instructed to avoid unintentional eye contact.
- Do not use the laser on reflective workpieces.
- Do not use optical tools to view or reflect the laser beam.
- Do not disassemble or remove the laser or aperture cover.
- Modifying the laser or product in any way can increase the risk of laser radiation.
- Use of adjustments or performance of procedures other than those specified in this manual may result in hazardous laser radiation exposure.
- Do not operate in explosive atmospheres, such as in the presence of flammable liquids, gases, or dust.
- Use only laser parts and accessories that are recommended or provided by the manufacturer for your model.
- Repairs and servicing **must** be performed by qualified personnel.
- Do not remove or deface the laser safety label.

ADDITIONAL SAFETY INFORMATION

1. ANSI Standard Z49.1, Safety in Welding and Cutting, American Welding Society, 550 LeJeune Road, P.O. Box 351020, Miami, FL 33135
2. ANSI Standard Z49.2, Fire Prevention in the Use of Cutting and Welding Processes, American National Standards Institute, 1430 Broadway, New York, NY 10018
3. ANSI Standard Z87.1, Safe Practices for Occupation and Educational Eye and Face Protection, American National Standards Institute, 1430 Broadway, New York, NY 10018
4. AWS F4.1, Recommended Safe Practices for the Preparation for Welding and Cutting of Containers and Piping That Have Held Hazardous Substances, American Welding Society, 550 LeJeune Road, P.O. Box 351040, Miami, FL 33135
5. AWS F5.2, Recommended Safe Practices for Plasma Arc Cutting, American Welding Society, 550 LeJeune Road, P.O. Box 351040, Miami, FL 33135
6. CGA Pamphlet P-1, Safe Handling of Compressed Gases in Cylinders, Compressed Gas Association, 1235 Jefferson Davis Highway, Arlington, VA 22202
7. CSA Standard W117.2, Code for Safety in Welding and Cutting, Canadian Standards Association Standard Sales, 178 Rexdale Boulevard, Rexdale, Ontario M9W 1R3, Canada
8. NFPA Standard 51B, Cutting and Welding Processes, National Fire Protection Association, 1 Batterymarch Park, Quincy, MA 02169-7471
9. NFPA Standard 70, National Electrical Code, National Fire Protection Association, 1 Batterymarch Park, Quincy, MA 02169-7471
10. OSHA, Safety and Health Standards, 29FR 1910 U.S. Government Printing Office, Washington, D.C. 20402
11. AWS Safety and Health Fact Sheets, American Welding Society, 550 LeJeune Road, P.O. Box 351040, Miami, FL 33135, www.aws.org/technical/facts/

Introduction

Hypertherm maintains a global Regulatory Management System to ensure that products comply with regulatory and environmental requirements.

National and local safety regulations

National and Local safety regulations shall take precedence over any instructions provided with the product. The product shall be imported, installed, operated and disposed of in accordance with national and local regulations applicable to the installed site.

Certification test marks

Certified products are identified by one or more certification test marks from accredited testing laboratories. The certification test marks are located on or near the data plate.

Each certification test mark means that the product and its safety-critical components conform to the relevant national safety standards as reviewed and determined by that testing laboratory. Hypertherm places a certification test mark on its products only after that product is manufactured with safety-critical components that have been authorized by the accredited testing laboratory.

Once the product has left the Hypertherm factory, the certification test marks are invalidated if any of the following occurs:

- The product is modified in a manner that creates a hazard or non-conformance with the applicable standards.
- Safety-critical components are replaced with unauthorized spare parts.
- Any unauthorized assembly, or accessory that uses or generates a hazardous voltage is added.
- There is any tampering with a safety circuit or other feature that is designed into the product as part of the certification, or otherwise.

CE marking constitutes a manufacturer's declaration of conformity to applicable European directives and standards. Only those versions of Hypertherm products with a CE Marking located on or near the data plate have been tested for compliance with the European Low Voltage Directive and the European EMC Directive. EMC filters needed to comply with the European EMC Directive are incorporated within versions of the power supply with a CE Marking.

Certificates of compliance for Hypertherm products are available from the Documents Library on the Hypertherm web site at www.hypertherm.com/docs.

Differences in national standards

Nations may apply different performance, safety or other standards. National differences in standards include, but are not limited to:

- Voltages
- Plug and cord ratings
- Language requirements
- Electromagnetic compatibility requirements

These differences in national or other standards may make it impossible or impractical for all certification test marks to be placed on the same version of a product. For example, the CSA versions of Hypertherm's products do not comply with European EMC requirements, and therefore do not have a CE marking on the data plate.

Countries that require CE marking or have compulsory EMC regulations must use CE versions of Hypertherm products with the CE marking on the data plate. These include, but are not limited to:

- Australia
- New Zealand
- Countries in the European Union
- Russia

It is important that the product and its certification test mark be suitable for the end-use installation site. When Hypertherm products are shipped to one country for export to another country; the product must be configured and certified properly for the end-use site.

Safe installation and use of shape cutting equipment

IEC 60974-9, titled Arc Welding Equipment – Installation and use, provides guidance in the safe installation and use of shape cutting equipment and the safe performance of cutting operations. The requirements of national and local regulations shall be taken into consideration during installation, including, but not limited to, grounding or protective earth connections, fuses, supply disconnecting device, and type of supply circuit. Read these instructions before installing the equipment. The first and most important step is the safety assessment of the installation.

The safety assessment must be performed by an expert, and determines what steps are necessary to create a safe environment, and what precautions should be adopted during the actual installation and operation.

Procedures for periodic inspection and testing

Where required by local national regulations, IEC 60974-4 specifies test procedures for periodic inspection and after repair or maintenance, to ensure electrical safety for plasma cutting power sources built in conformity with IEC 60974-1. Hypertherm performs the continuity of the protective circuit and insulation resistance tests in the factory as non-operating tests. The tests are performed with the power and ground connections removed.

Hypertherm also removes some protective devices that would cause false test results. Where required by local national regulations, a label shall be attached to the equipment to indicate that it has passed the tests prescribed by IEC 60974-4. The repair report shall indicate the results of all tests unless an indication is made that a particular test has not been performed.

Qualification of test personnel

Electrical safety tests for shape cutting equipment can be hazardous and shall be carried out by an expert in the field of electrical repair, preferably someone also familiar with welding, cutting, and allied processes. The safety risks to personnel and equipment, when unqualified personnel are performing these tests, may be much greater than the benefit of periodic inspection and testing.

Hypertherm recommends that only visual inspection be performed unless the electrical safety tests are specifically required by local national regulations in the country where the equipment is installed.

Residual current devices (RCDs)

In Australia and some other countries, local codes may require the use of a Residual Current Devices (RCD) when portable electrical equipment is used in the workplace or at construction sites to protect operators from electrical faults in the equipment. RCDs are designed to safely disconnect the mains electrical supply when an imbalance is detected between the supply and return current (there is a leakage current to earth). RCDs are available with both fixed and adjustable trip currents between 6 to 40 milliamperes and a range of trip times up to 300 milliseconds selected for the equipment installation, application and intended use. Where RCDs are used, the trip current and trip time on RCDs should be selected or adjusted high enough to avoid nuisance tripping during normal operation of the plasma cutting equipment and low enough in the extremely unlikely event of an electrical fault in the equipment to disconnect the supply before the leakage current under a fault condition can pose a life threatening electrical hazard to operators.

To verify that the RCDs continue to function properly over time, both the trip current and the trip time should be tested periodically. Portable electrical equipment and RCDs used in commercial and industrial areas in Australia and New Zealand are tested to the Australian standard AS/NZS 3760. When you test the insulation of plasma cutting equipment to AS/NZS 3760, measure the insulation resistance according to Appendix B of the standard, at 250 VDC with the power switch in the ON position to verify proper testing and to avoid the false failure of the leakage current test. False failures are possible because the metal oxide varistors (MOVs) and electromagnetic compatibility (EMC) filters, used to reduce emissions and protect the equipment from power surges, may conduct up to 10 milliamperes leakage current to earth under normal conditions.

If you have any questions regarding the application or interpretation of any IEC standards described here, you are required to consult with an appropriate legal or other advisor familiar with the International Electrotechnical standards, and shall not rely on Hypertherm in any respect regarding the interpretation or application of such standards.

Higher-level systems

When a system integrator adds additional equipment; such as cutting tables, motor drives, motion controllers or robots; to a Hypertherm plasma cutting system, the combined system may be considered a higher-level system. A higher-level system with hazardous moving parts may constitute industrial machinery or robotic equipment, in which case the OEM or end-use customer may be subject to additional regulations and standards than those relevant to the plasma cutting system as manufactured by Hypertherm.

It is the responsibility of the end-use customer and the OEM to perform a risk assessment for the higher-level system, and to provide protection against hazardous moving parts. Unless the higher-level system is certified when the OEM incorporates Hypertherm products into it, the installation also may be subject to approval by local authorities. Seek advice from legal counsel and local regulatory experts if you are uncertain about compliance.

External interconnecting cables between component parts of the higher level system must be suitable for contaminants and movement as required by the final end use installation site. When the external interconnecting cables are subject to oil, dust, water, or other contaminants, hard usage ratings may be required.

When external interconnecting cables are subject to continuous movement, constant flexing ratings may be required. It is the responsibility of the end-use customer or the OEM to ensure the cables are suitable for the application. Since there are differences in the ratings and costs that can be required by local regulations for higher level systems, it is necessary to verify that any external interconnecting cables are suitable for the end-use installation site.

Introduction

The Hypertherm Environmental Specification requires RoHS, WEEE and REACH substance information to be provided by Hypertherm's suppliers.

Product environmental compliance does not address the indoor air quality or environmental release of fumes by the end user. Any materials that are cut by the end user are not provided by Hypertherm with the product. The end user is responsible for the materials being cut as well as for safety and air quality in the workplace. The end user must be aware of the potential health risks of the fumes released from the materials being cut and comply with all local regulations.

National and local environmental regulations

National and local environmental regulations shall take precedence over any instructions contained in this manual.

The product shall be imported, installed, operated and disposed of in accordance with all national and local environmental regulations applicable to the installed site.

The European Environmental regulations are discussed later in *The WEEE Directive*.

The RoHS directive

Hypertherm is committed to complying with all applicable laws and regulations, including the European Union Restriction of Hazardous Substances (RoHS) Directive that restricts the use of hazardous materials in electronics products. Hypertherm exceeds RoHS Directive compliance obligations on a global basis.

Hypertherm continues to work toward the reduction of RoHS materials in our products, which are subject to the RoHS Directive, except where it is widely recognized that there is no feasible alternative.

Declarations of RoHS Conformity have been prepared for the current CE versions of Hypertherm products that fall within the scope of the RoHS Directive. These RoHS-compliant products also have a "RoHS mark" near the "CE Marking" on the data plate. Parts and other products manufactured by Hypertherm that are either out of scope or exempt from RoHS are continuously being converted to RoHS compliance in anticipation of future requirements, and there is no "RoHS mark" on their data plates.

Proper disposal of Hypertherm products

Hypertherm plasma cutting systems, like all electronic products, may contain materials or components, such as printed circuit boards, that cannot be discarded with ordinary waste. It is your responsibility to dispose of any Hypertherm product or component part in an environmentally acceptable manner according to national and local codes.

- In the United States, check all federal, state, and local laws.
- In the European Union, check the EU directives, national, and local laws.
- In other countries, check national and local laws.
- Consult with legal or other compliance experts when appropriate.

A variety of options for sustainable disposal of Hypertherm products are available on our website at www.hypertherm.com/recycle.

The WEEE Directive

The European Parliament and the Council of the European Union authorized Directive 2012/19/EU or WEEE (Waste Electrical and Electronic Equipment) Recast.

As required by the legislation, any Hypertherm product covered by the directive and sold in the EU after August 13, 2005 is marked with the WEEE symbol. This directive encourages and sets specific criteria for the collection, handling, and recycling of EEE waste. Consumer and business-to-business wastes are treated differently (all Hypertherm products are considered business-to-business). Disposal options for Hypertherm systems can be found at www.hypertherm.com/recycle.

The URL is printed on the symbol-only warning label for each CE version Hypertherm plasma system since 2006. The CSA versions of products manufactured by Hypertherm are either out of scope or exempt from WEEE.

The REACH regulation

The REACH regulation, in force since June 1, 2007, has an impact on chemicals available to the European market. The REACH regulation requirements for component manufacturers states that the component shall not contain more than 0.1% by weight of the Substances of Very High Concern (SVHC).

Component manufacturers and other downstream users, such as Hypertherm, are obligated to obtain assurances from its suppliers that all chemicals used in or on Hypertherm products will have a European Chemical Agency (ECHA) registration number. To provide chemical information as required by the REACH regulation, Hypertherm requires suppliers to provide REACH declarations and identify any known use of REACH SVHC. Any use of SVHC in amounts exceeding 0.1% w/w of the parts has been eliminated.

The lubricants, sealants, coolants, adhesives, solvents, coatings and other preparations or mixtures used by Hypertherm in, on, for, or with its shape cutting equipment are used in very small quantities (except the coolant) and are commercially available with multiple sources that can and will be replaced in the event of a supplier problem associated with REACH Registration or REACH Authorization (SVHCs).

Proper handling and safe use of chemicals

Chemical Regulations in the USA, Europe, and other locations require that Material Safety Data Sheets (MSDS) or Safety Data Sheets (SDS) be made available for all chemicals. The list of chemicals is provided by Hypertherm. The MSDS are for chemicals provided with the product and other chemicals used in or on the product. MSDS can be downloaded from the Documents Library on the Hypertherm web site at www.hypertherm.com/docs. In the Documents Library, select "Material Safety Data Sheets" in the Category drop-down menu.

In the USA, OSHA does not require Material Safety Data Sheets for articles such as electrodes, swirl rings, retaining caps, nozzles, shields, deflectors and other solid parts of the torch.

Hypertherm does not manufacture or provide the materials that are cut and has no knowledge whether the fumes released from materials that are cut will pose a physical hazard or health risk. Please consult with your supplier or other technical advisor if you need guidance concerning the properties of the material you will cut using a Hypertherm product.

Fumes emission and air quality

Note: The following information on air quality is intended for general information only and should not be used as a substitute for reviewing and implementing applicable government regulations or legal standards in the country where the cutting equipment will be installed and operated.

In the USA, the National Institute for Occupational Safety and Health (NIOSH) Manual of Analytical Methods (NMAM) is a collection of methods for sampling and analyzing contaminants in workplace air. Methods published by others, such as OSHA, MSHA, EPA, ASTM, ISO or commercial suppliers of sampling and analytical equipment, may have advantages over NIOSH methods.

For example, ASTM Practice D 4185 is a standard practice for the collection, dissolution, and determination of trace metals in workplace atmospheres. The sensitivity, detection limit, and optimum working concentrations for 23 metals are listed in ASTM D 4185. An industrial hygienist should be used to determine the optimum sampling protocol, considering analytical accuracy, cost, and optimum sample number. Hypertherm uses a third party industrial hygienist to perform and interpret air quality testing results taken by air sampling equipment positioned at operator stations in Hypertherm buildings where plasma cutting tables are installed and operated.

Where applicable, Hypertherm also uses a third party industrial hygienist to obtain air and water permits.

If you are not fully aware and up to date on all applicable government regulations and legal standards for the installation site, you should consult a local expert prior to purchasing, installing, and operating the equipment.

Introduction

Hypertherm's CE-marked equipment is built in compliance with standard EN60974-10. The equipment should be installed and used in accordance with the information below to achieve electromagnetic compatibility.

The limits required by EN60974-10 may not be adequate to completely eliminate interference when the affected equipment is in close proximity or has a high degree of sensitivity. In such cases it may be necessary to use other measures to further reduce interference.

This cutting equipment is designed for use only in an industrial environment.

Installation and use

The user is responsible for installing and using the plasma equipment according to the manufacturer's instructions.

If electromagnetic disturbances are detected then it shall be the responsibility of the user to resolve the situation with the technical assistance of the manufacturer. In some cases this remedial action may be as simple as earthing the cutting circuit, see *Earthing of the workpiece*. In other cases, it could involve constructing an electromagnetic screen enclosing the power source and the work complete with associated input filters. In all cases, electromagnetic disturbances must be reduced to the point where they are no longer troublesome.

Assessment of area

Before installing the equipment, the user shall make an assessment of potential electromagnetic problems in the surrounding area. The following shall be taken into account:

- a. Other supply cables, control cables, signaling and telephone cables; above, below and adjacent to the cutting equipment.
- b. Radio and television transmitters and receivers.
- c. Computer and other control equipment.
- d. Safety critical equipment, for example guarding of industrial equipment.
- e. Health of the people around, for example the use of pacemakers and hearing aids.
- f. Equipment used for calibration or measurement.
- g. Immunity of other equipment in the environment. User shall ensure that other equipment being used in the environment is compatible. This may require additional protection measures.
- h. Time of day that cutting or other activities are to be carried out.

The size of the surrounding area to be considered will depend on the structure of the building and other activities that are taking place. The surrounding area may extend beyond the boundaries of the premises.

Methods of reducing emissions

Mains supply

Cutting equipment must be connected to the mains supply according to the manufacturer's recommendations. If interference occurs, it may be necessary to take additional precautions such as filtering of the mains supply.

Consideration should be given to shielding the supply cable of permanently installed cutting equipment, in metallic conduit or equivalent. Shielding should be electrically continuous throughout its length. The shielding should be connected to the cutting mains supply so that good electrical contact is maintained between the conduit and the cutting power source enclosure.

Maintenance of cutting equipment

The cutting equipment must be routinely maintained according to the manufacturer's recommendations. All access and service doors and covers should be closed and properly fastened when the cutting equipment is in operation. The cutting equipment should not be modified in any way, except as set forth in and in accordance with the manufacturer's written instructions. For example, the spark gaps of arc striking and stabilizing devices should be adjusted and maintained according to the manufacturer's recommendations.

Cutting cables

The cutting cables should be kept as short as possible and should be positioned close together, running at or close to the floor level.

Equipotential bonding

Bonding of all metallic components in the cutting installation and adjacent to it should be considered.

However, metallic components bonded to the workpiece will increase the risk that the operator could receive a shock by touching these metallic components and the electrode (nozzle for laser heads) at the same time.

The operator should be insulated from all such bonded metallic components.

Electromagnetic Compatibility (EMC)

Earthing of the workpiece

Where the workpiece is not bonded to earth for electrical safety, nor connected to earth because of its size and position, for example, ship's hull or building steel work, a connection bonding the workpiece to earth may reduce emissions in some, but not all instances. Care should be taken to prevent the earthing of the workpiece increasing the risk of injury to users, or damage to other electrical equipment. Where necessary, the connection of the workpiece to earth should be made by a direct connection to the workpiece, but in some countries where direct connection is not permitted, the bonding should be achieved by suitable capacitances selected according to national regulations.

Note: The cutting circuit may or may not be earthed for safety reasons. Changing the earthing arrangements should only be authorized by a person who is competent to assess whether the changes will increase the risk of injury, for example, by allowing parallel cutting current return paths which may damage the earth circuits of other equipment. Further guidance is provided in IEC 60974-9, Arc Welding Equipment, Part 9: Installation and Use.

Screening and shielding

Selective screening and shielding of other cables and equipment in the surrounding area may alleviate problems of interference. Screening of the entire plasma cutting installation may be considered for special applications.

Attention

Genuine Hypertherm parts are the factory-recommended replacement parts for your Hypertherm system. Any damage or injury caused by the use of other than genuine Hypertherm parts may not be covered by the Hypertherm warranty, and will constitute misuse of the Hypertherm Product.

You are solely responsible for the safe use of the Product. Hypertherm does not and cannot make any guarantee or warranty regarding the safe use of the product in your environment.

General

Hypertherm Inc. warrants that its Products shall be free from defects in materials and workmanship for the specific periods of time set forth herein and as follows: if Hypertherm is notified of a defect (i) with respect to the plasma power supply within a period of two (2) years from the date of its delivery to you, with the exception of Powermax brand power supplies, which shall be within a period of three (3) years from the date of delivery to you, and (ii) with respect to the torch and leads within a period of one (1) year from its date of delivery to you, with the exception of the HPRXD short torch with integrated lead, which shall be within a period of six (6) months from the date of delivery to you, and with respect to torch lifter assemblies within a period of one (1) year from its date of delivery to you, and with respect to Automation products one (1) year from its date of delivery to you, with the exception of the EDGE Connect CNC, EDGE Connect T CNC, EDGE Connect TC CNC, EDGE Pro CNC, EDGE Pro Ti CNC, MicroEDGE Pro CNC, and ArcGlide THC, which shall be within a period of two (2) years from the date of delivery to you, and (iii) with respect to HyIntensity fiber laser components within a period of two (2) years from the date of its delivery to you, with the exception of laser heads and beam delivery cables, which shall be within a period of one (1) year from its date of delivery to you.

This warranty shall not apply to any Powermax brand power supplies that have been used with phase converters. In addition, Hypertherm does not warranty systems that have been damaged as a result of poor power quality, whether from phase converters or incoming line power. This warranty shall not apply to any product which has been incorrectly installed, modified, or otherwise damaged.

Hypertherm provides repair, replacement or adjustment of the Product as the sole and exclusive remedy, if and only if the warranty set forth herein properly is invoked and applies. Hypertherm, at its sole option, shall repair, replace, or adjust, free of charge, any defective Products covered by this warranty which shall be returned with Hypertherm's prior authorization (which shall not be unreasonably withheld), properly packed, to Hypertherm's place of business in Hanover, New Hampshire, or to an authorized Hypertherm repair facility, all costs, insurance and freight pre paid by the customer. Hypertherm shall not be liable for any repairs, replacement, or adjustments of Products covered by this warranty, except those made pursuant to this paragraph and with Hypertherm's prior written consent.

The warranty set forth above is exclusive and is in lieu of all other warranties, express, implied, statutory, or otherwise with respect to the Products or as to the results which may be obtained therefrom, and all implied warranties or conditions of quality or of merchantability or fitness for a particular purpose or against infringement. The foregoing shall constitute the sole and exclusive remedy for any breach by Hypertherm of its warranty.

Distributors/OEMs may offer different or additional warranties, but Distributors/OEMs are not authorized to give any additional warranty protection to you or make any representation to you purporting to be binding upon Hypertherm.

Patent indemnity

Except only in cases of products not manufactured by Hypertherm or manufactured by a person other than Hypertherm not in strict conformity with Hypertherm's specifications and in cases of designs, processes, formulae, or combinations not developed or purported to be developed by Hypertherm, Hypertherm will have the right to defend or settle, at its own expense, any suit or proceeding brought against you alleging that the use of the Hypertherm product, alone and not in combination with any other product not supplied by Hypertherm, infringes any patent of any third party. You shall notify Hypertherm promptly upon learning of any action or threatened action in connection with any such alleged infringement (and in any event no longer than fourteen (14) days after learning of any action or threat of action), and Hypertherm's obligation to defend shall be conditioned upon Hypertherm's sole control of, and the indemnified party's cooperation and assistance in, the defense of the claim.

Limitation of liability

In no event shall Hypertherm be liable to any person or entity for any incidental, consequential direct, indirect, punitive or exemplary damages (including but not limited to lost profits) regardless of whether such liability is based on breach of contract, tort, strict liability, breach of warranty, failure of essential purpose, or otherwise, and even if advised of the possibility of such damages. Hypertherm shall not be liable for any losses to Distributor based on down time, lost production or lost profits. It is the intention of the Distributor and Hypertherm that this provision be construed by a court as being the broadest limitation of liability consistent with applicable law.

National and local codes

National and local codes governing plumbing and electrical installation shall take precedence over any instructions contained in this manual. In no event shall Hypertherm be liable for injury to persons or property damage by reason of any code violation or poor work practices.

Warranty

Liability cap

In no event shall Hypertherm's liability, if any, whether such liability is based on breach of contract, tort, strict liability, breach of warranties, failure of essential purpose or otherwise, for any claim, action, suit or proceeding (whether in court, arbitration, regulatory proceeding or otherwise) arising out of or relating to the use of the Products exceed in the aggregate the amount paid for the Products that gave rise to such claim.

Insurance

At all times you will have and maintain insurance in such quantities and types, and with coverage sufficient and appropriate to defend and to hold Hypertherm harmless in the event of any cause of action arising from the use of the products.

Transfer of rights

You may transfer any remaining rights you may have hereunder only in connection with the sale of all or substantially all of your assets or capital stock to a successor in interest who agrees to be bound by all of the terms and conditions of this Warranty. Within thirty (30) days before any such transfer occurs, you agree to notify in writing Hypertherm, which reserves the right of approval. Should you fail timely to notify Hypertherm and seek its approval as set forth herein, the Warranty set forth herein shall be null and void and you will have no further recourse against Hypertherm under the Warranty or otherwise.

Waterjet product warranty coverage

Product	Parts coverage
HyPrecision pumps	27 months from the ship date, or 24 months from the date of proven installation, or 4,000 hours, whichever occurs first
PowerDredge abrasive removal system	15 months from the ship date or 12 months from the date of proven installation, whichever occurs first
EcoSift abrasive recycling system	15 months from the ship date or 12 months from the date of proven installation, whichever occurs first
Abrasive metering devices	15 months from the ship date or 12 months from the date of proven installation, whichever occurs first
On/off valve air actuators	15 months from the ship date or 12 months from the date of proven installation, whichever occurs first
Diamond orifices	600 hours of use with the use of a thimble filter and compliance with Hypertherm's water quality requirements

Consumable parts are not covered by this warranty. Consumable parts include, but are not limited to, high-pressure water seals, check valves, cylinders, bleed-down valves, low-pressure seals, high-pressure tubing, low- and high-pressure water filters and abrasive collection bags. All third-party pumps, pump accessories, hoppers, hopper accessories, dryer boxes, dryer box accessories and plumbing accessories are covered by the respective manufacturers' warranties and not covered by this warranty.

1

Overview

The Hypertherm Sensor THC Plasma Lifter accessory supplies lifter mechanics that you combine with a motor and drive for torch height control.

The Sensor THC Plasma Lifter is compatible with the Phoenix® Sensor THC software features that run on EDGE® Pro, MicroEDGE® Pro, EDGE Connect, EDGE Connect T, and EDGE Connect TC computer numerical controllers (CNCs).

2

Specifications and parts

Upon receipt

- Make sure that you received all items on your order in good condition. Contact your distributor if any parts are damaged or missing.
- Inspect the items for damage that may have occurred during shipment. If you find evidence of damage, see *Claims*, below. All communications regarding this equipment must include the model number and the serial number.
- Before you set up this equipment, read the safety information included with your equipment. Failure to follow safety instructions can result in personal injury or in damage to equipment.

Claims

- Claims for damage during shipment – If your equipment was damaged during shipment, file a claim with the carrier. You can contact Hypertherm for a copy of the bill of lading. If you need additional assistance, call the nearest Hypertherm office listed in the front of this manual.
- Claims for defective or missing merchandise – If any component is missing or defective, contact your Hypertherm distributor. If you need additional assistance, call the nearest Hypertherm office listed in the front of this manual.

Sensor THC Plasma Lifter

The Hypertherm Sensor THC Plasma Lifter has the following specifications.

Table 1 – Specifications

Upper limit switch (Home)	+24 VDC
Lower limit switch	+24 VDC
Breakaway switch	+24 VDC
Sensor signal type	PNP N/O (normally open)
Maximum Z-axis speed	15,200 mm/min (600 in/min) (recommended maximum)
Maximum Z-axis stroke	239 mm (9.40 in.)
Lead screw pitch	5.0 mm/revolution (0.20 in/revolution)
Lifter capacity	11.3 kg (25.0 lb) (recommended maximum)
Motor mount	60 mm (2.36 in.) flange with a 70 mm (2.756 in.) bolt circle diameter Note: Hypertherm does not offer a motor for the Sensor THC Plasma Lifter. See <i>Figure 2</i> on page 32 for motor mount specifications.



For signal and lifter interface specifications, see *Table 7* on page 48.

The following Sensor THC Plasma Lifter assemblies are available from Hypertherm.

Table 2 – Assemblies

Part number	Torch mounting block	Magnetic breakaway
090187	Not included (lifter only)	Not included (lifter only)
090188	Not included	4.5 kg (10 lb)
090189	Not included	11 kg (25 lb)
090190	35 mm (1-3/8 in.)	4.5 kg (10 lb)
090191	35 mm (1-3/8 in.)	11 kg (25 lb)
090192	44 mm (1-3/4 in.)	4.5 kg (10 lb)
090193	44 mm (1-3/4 in.)	11 kg (25 lb)
090194	51 mm (2 in.)	4.5 kg (10 lb)
090195	51 mm (2 in.)	11 kg (25 lb)
090197	57 mm (2-1/4 in.)	11 kg (25 lb)

Figure 1 – Lifter dimensions (090195 model shown)

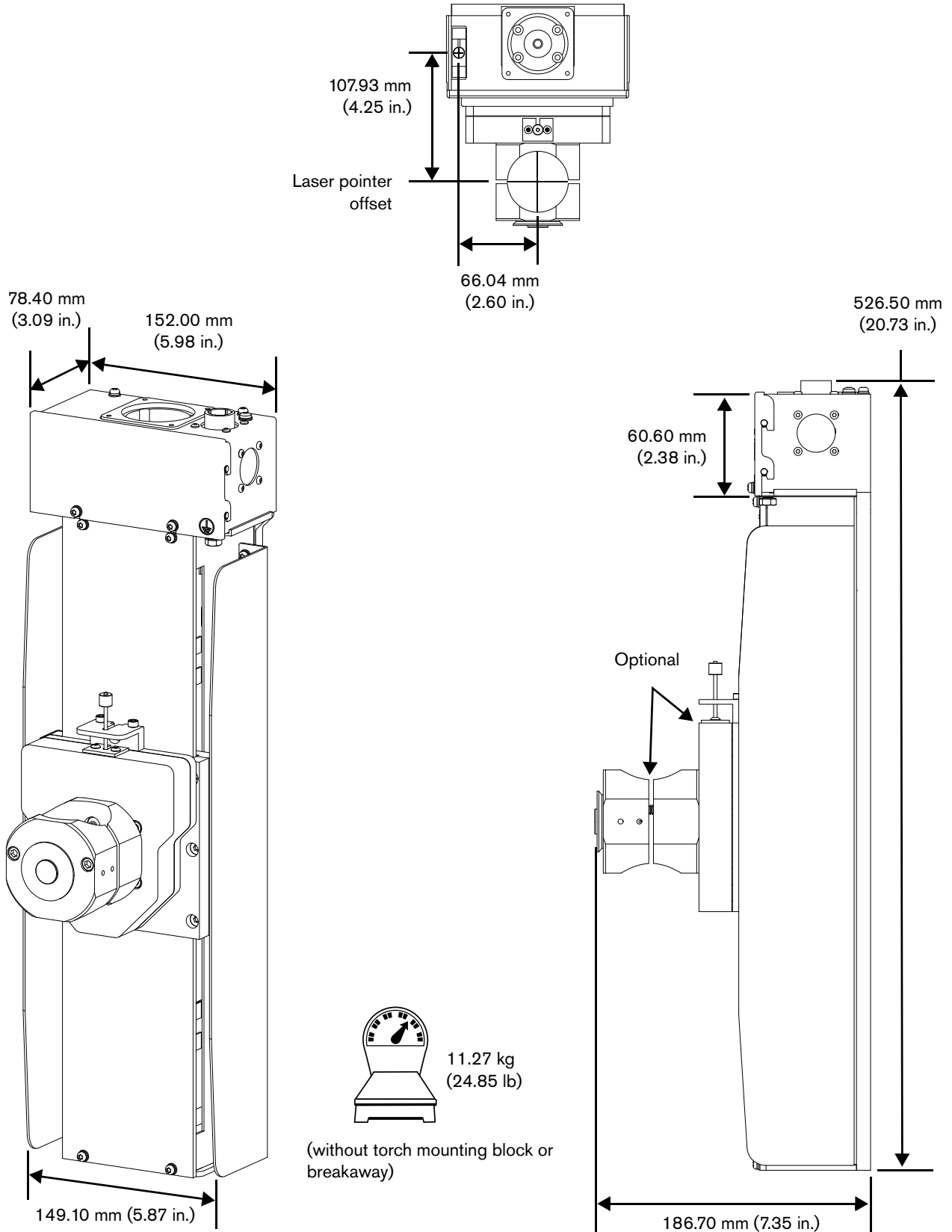

Data plate

The data plate shows the lifter's part number and serial number. If you contact Hypertherm Technical Service, they ask for this information.

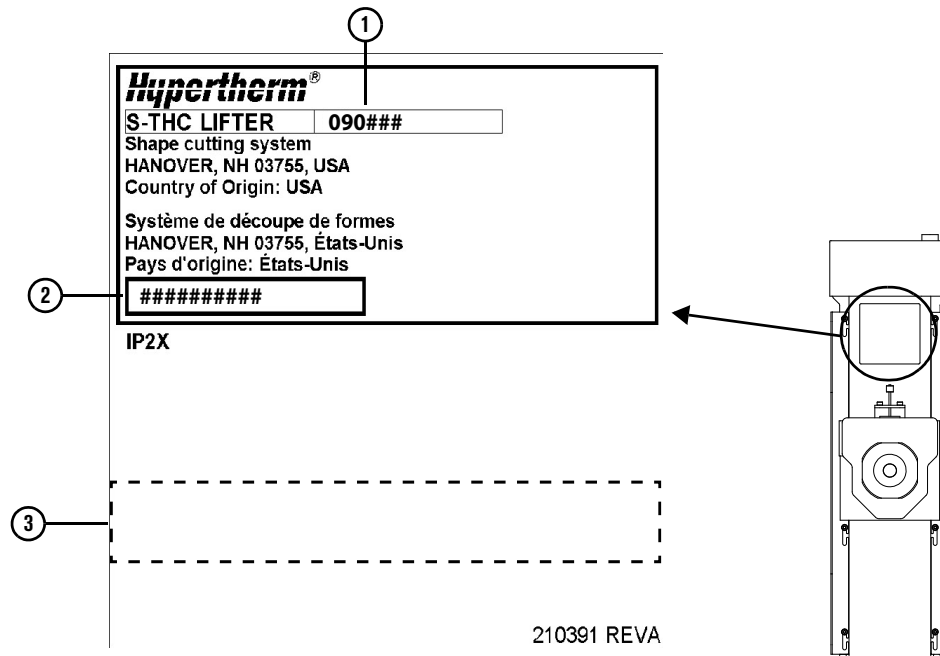

- 1 Part number
- 2 Serial number (YYMM#####, where YY is the year and MM is the month of manufacture)
- 3 Serial number bar code

Lifter interface cable

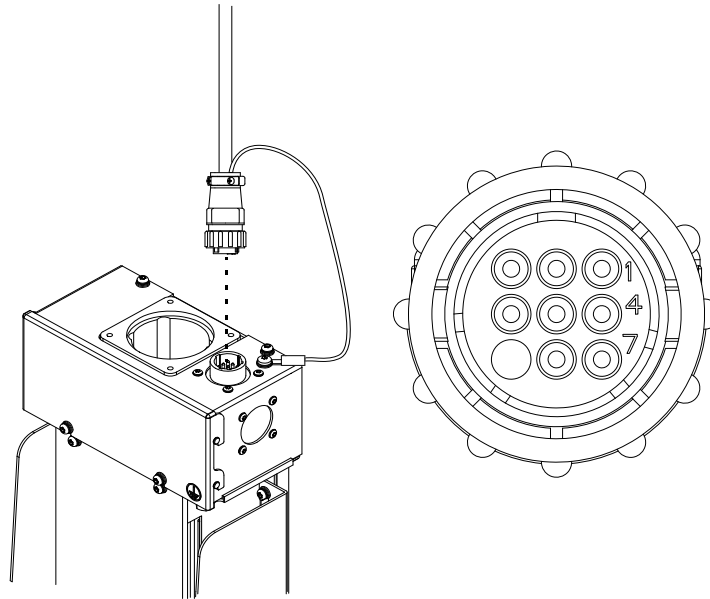

The lifter interface cable connects the lifter interface board and the lifter drive. See *Table 7* on page 48 for pinout information.

Table 3 – Lifter interface cables

Part number	Description	Quantity
223472	8 m (25 ft)	1
223473	15 m (50 ft)	1
223614	30 m (100 ft)	1

Motors and drives

Hypertherm does not offer a drive, motor, brake, or motor cables for the lifter.



We strongly recommend a motor and brake combination.

To select a compatible motor, see *Figure 2* on page 32 for the motor mount specifications. Select a drive that is compatible with your motor.

Figure 2 – Motor mount specifications

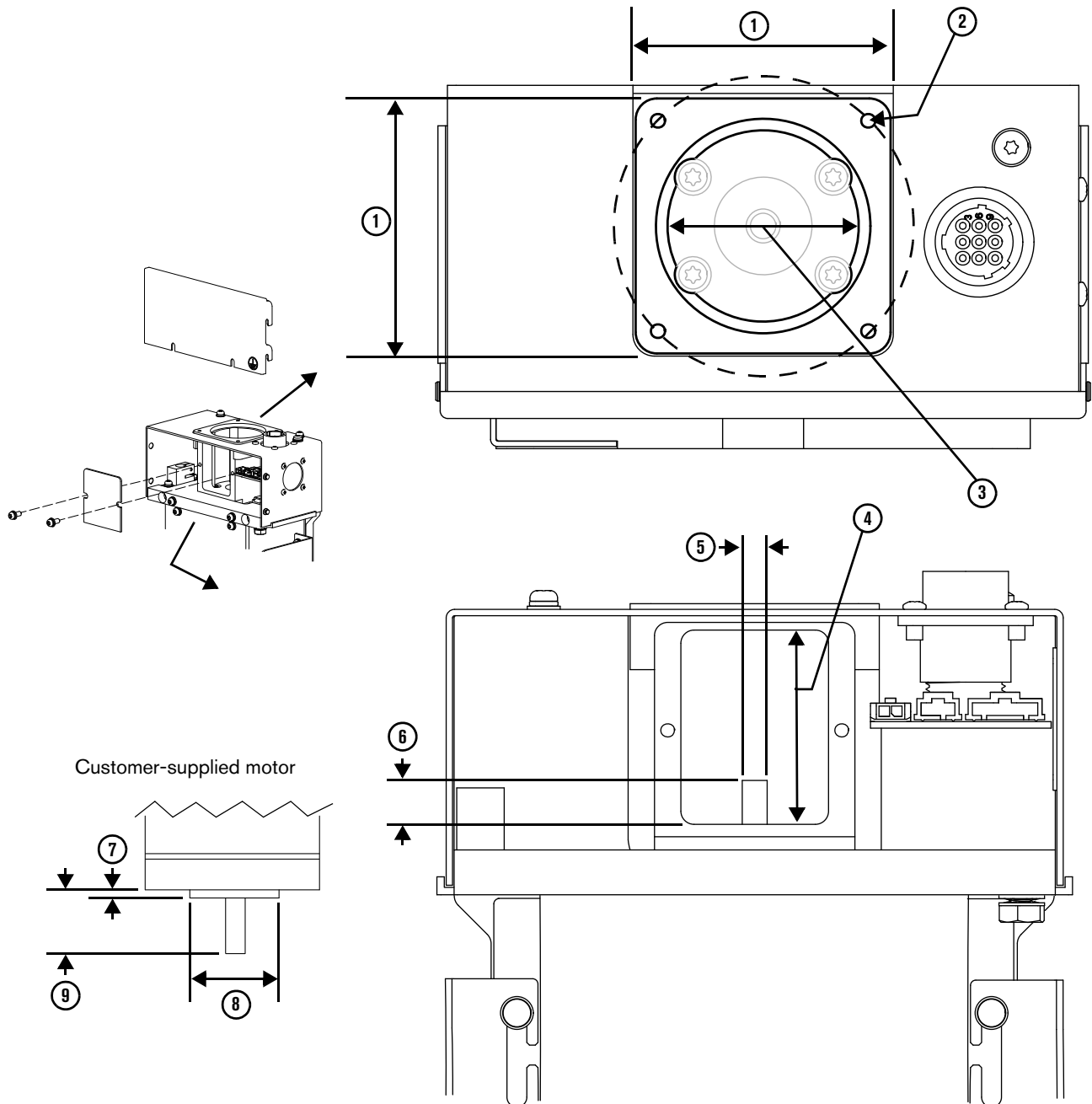

- 1 Motor mount flange: 60 mm (2.362 in.) square
- 2 Screws: four M4 X 0.70 mm screws on 70 mm (2.756 in.) bolt circle diameter
- 3 Coupling maximum diameter: 41 mm (1.615 in.)
- 4 Coupling maximum length: 45 mm (1.772 in.)
- 5 Linear slide shaft diameter: 6 mm (0.236 in.)

- 6 Linear side shaft height: 10.6 mm (0.416 in.)
- Customer-supplied motor specifications:
- 7 Pilot maximum length: 3.56 mm (0.140 in.)
 - 8 Pilot maximum diameter: 50.50 mm (1.988 in.)
 - 9 Motor shaft maximum length: 42.55 mm (1.675 in.)

Motor couplings

Couplings join the linear slide shaft and the motor shaft. Hypertherm supplies 2 flexible couplings (031165 and 031164). If you supply your own coupling, see *Figure 2* for coupling specifications.



For a strong connection, make sure that when you insert the linear slide shaft and the motor shaft into the coupling, each of them reaches at least past the coupling screws.

Figure 3 – Hypertherm couplings

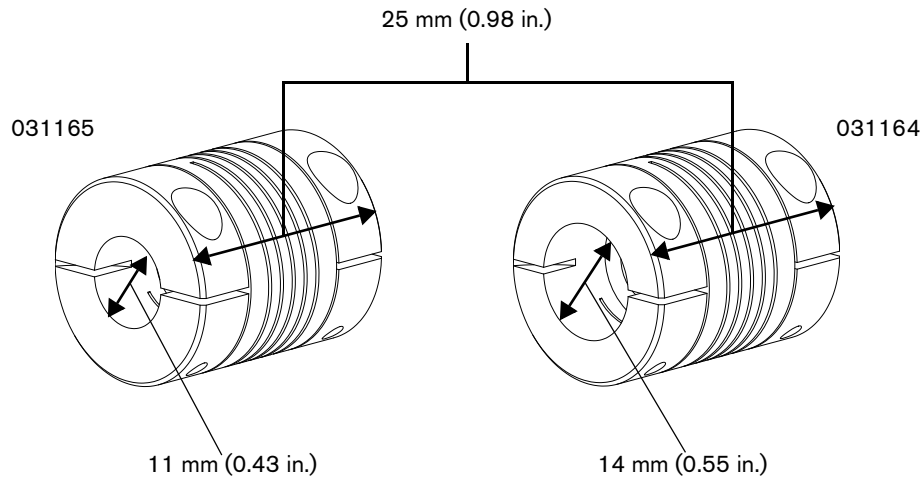

Table 4 – Hypertherm couplings

Part number	Description
031165	25 mm (0.98 in.) flexible coupling with 11 mm (0.43 in.) motor shaft diameter
031164	25 mm (0.98 in.) flexible coupling with 14 mm (0.55 in.) motor shaft diameter
Coupling screws hex head size is 2.50 mm (0.098 in.), with a torque rating of 9.2 kg·cm (8.0 in·lb).	

Replacement parts

Lifter parts

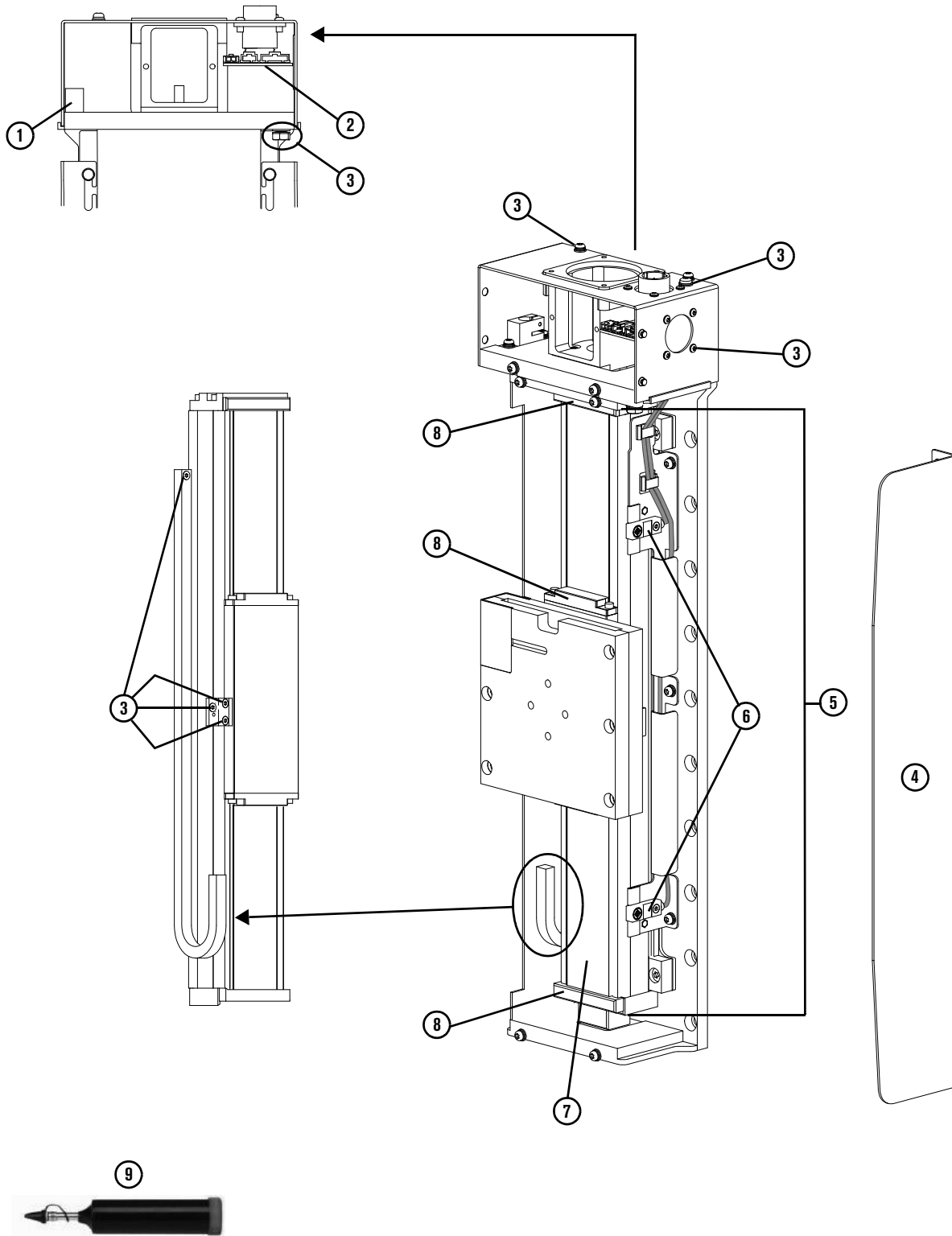

Table 5 – Replacement lifter parts

Item	Kit number	Description	Quantity
1	428453	Laser pointer	1
2	428452	Interface board	1
3	428651	Exterior hardware: <ul style="list-style-type: none"> ▪ Ground hex head bolt (1) and washers (2) ▪ Lifter screws (18) ▪ Interface cable ground screw (1) ▪ Interface cable connector screws (4) ▪ Breakaway cable track and bracket screws (4) 	30
4	428449	Side shields	2
5	428451	Slide	1
6	428450	Upper/lower limit switch	1
7	428612	Sealing strip	1
8	127505	Sealing strip hardware	1
9	428611	Grease gun	1

Breakaway parts

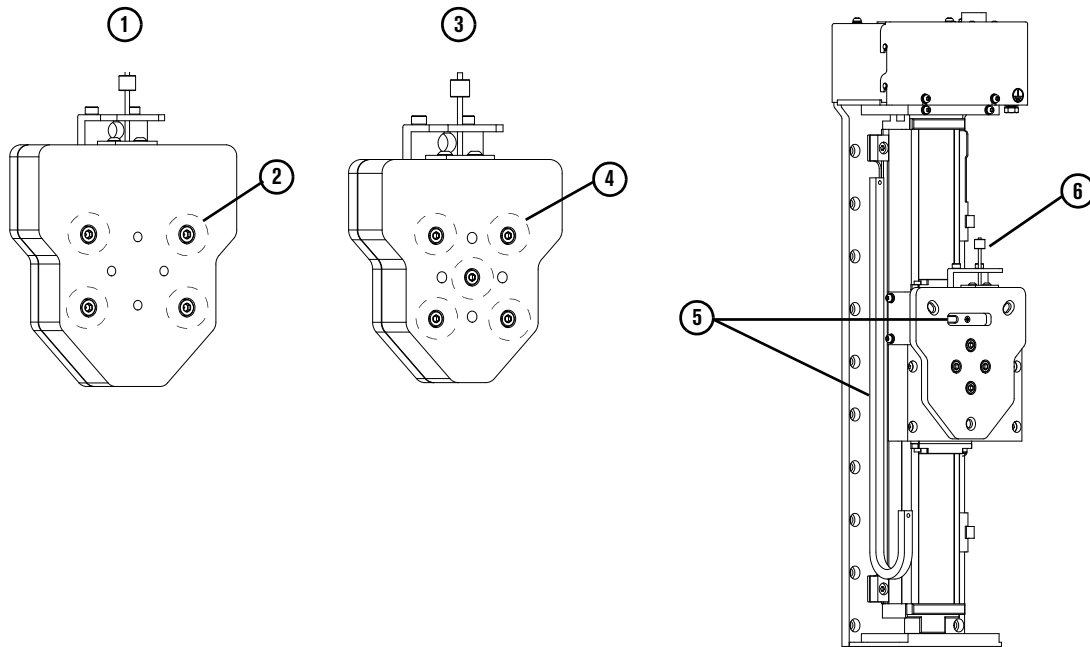

Table 6 – Breakaway replacement parts

Item	Kit number	Description	Quantity
1	428606	11.34 kgf (25 lbf) magnetic breakaway	1
2	104473	35.7 kgf (78.7 lbf) replacement magnet for 11.34 kgf (25 lbf) magnetic breakaway	1
2	428610	35.7 kgf (78.7 lbf) replacement magnets for 11.34 kgf (25 lbf) magnetic breakaway (set of 4)	4
3	428607	4.54 kgf (10 lbf) magnetic breakaway	1
4	104513	20 kgf (45 lbf) replacement magnet for 4.54 kgf (10 lbf) magnetic breakaway	1
4	428609	20 kgf (45 lbf) replacement magnets for 4.54 kgf (10 lbf) magnetic breakaway (set of 5)	5
5	428448	Breakaway cable and sensor	1
6	428608	Magnetic breakaway retaining tether	1

Wiring diagram

See Figure 4.

Figure 4

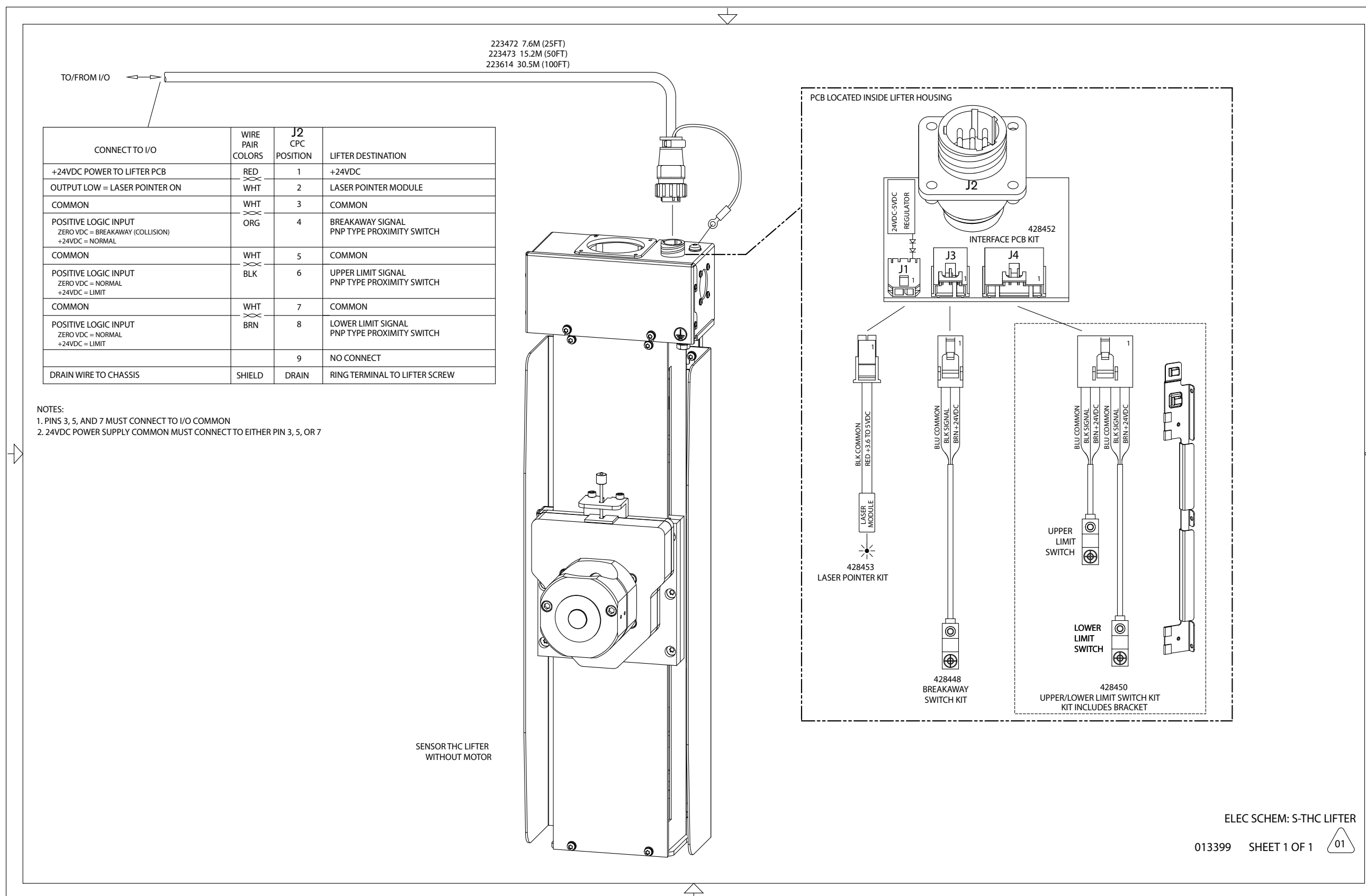

3 Install

Install the motor



Hypertherm does not offer a motor for the lifter. For motor mount specifications, see *Figure 2* on page 32.

1. Loosen the 2 screws on the front of the lifter interface enclosure.
2. Move the front panel up and off the 2 screws and the studs on the sides of the interface enclosure.
3. Remove the 2 screws from the motor coupling cover.
4. Remove the motor coupling cover.

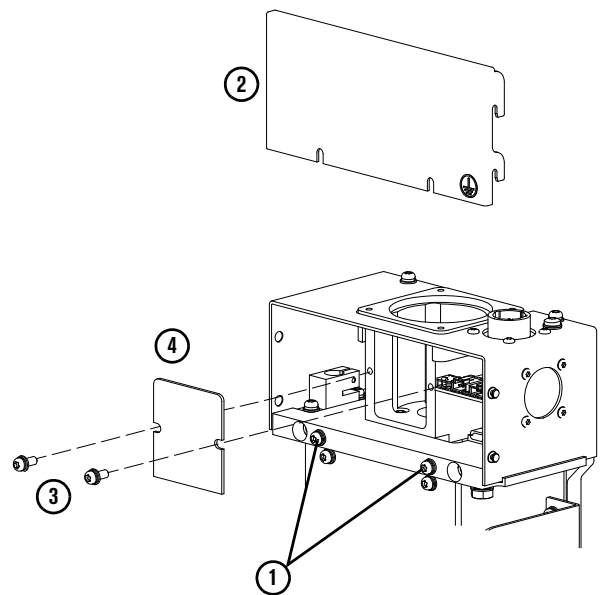

5. Put a coupling on the end of the motor shaft.
 - Hypertherm supplies 2 couplings. See *Figure 3* on page 33 for more information.
 - If you supply your own coupling, see *Figure 2* on page 32 for coupling specifications.
6. Put the motor and coupling on the linear slide shaft.



For a strong connection, make sure that when you connect the linear slide shaft and the motor shaft with the coupling, each of them reaches at least past the coupling screws.

7. Rotate the motor as necessary to keep the motor cables away from the gantry and the connector for the lifter interface cable.
 - If necessary, move the connector for the lifter interface cable to the side of the interface enclosure. See *Move the connector for the lifter interface cable (optional)* on page 41 for more information.

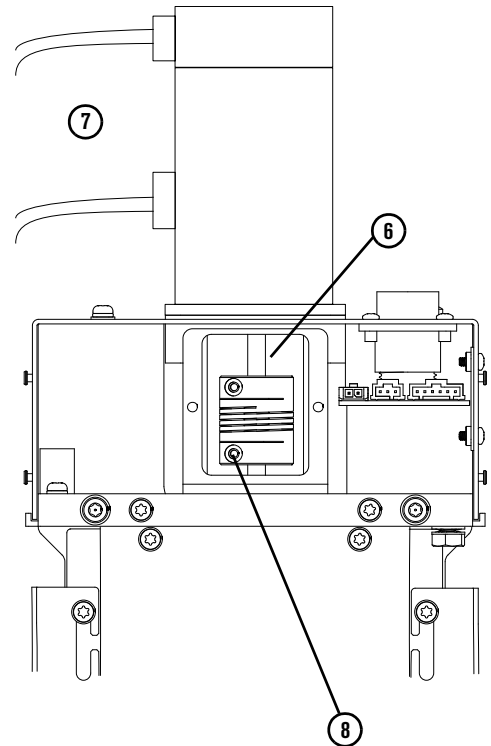

8. Make sure that you can access the 2 hex head screws on the coupling.
9. Use four M4 X 0.70 screws to attach the motor to the motor flange.
10. Tighten the 2 screws on the coupling to a torque of 9.2 kg·cm (8.0 in·lb).
11. Install the motor coupling cover.
12. Install the front panel of the interface enclosure.

Move the connector for the lifter interface cable (optional)

The lifter comes with the connector for the lifter interface cable on the top of the interface enclosure. You can move it to the side of the interface enclosure.

 The connector and the lifter interface board are one piece.

1. Remove the front panel of the interface enclosure. For more information, see *step 1* on page 39.
2. Disconnect the 3 wire harnesses from the lifter interface board.
3. Remove the 4 screws that attach the connector to the interface enclosure.
4. Remove the connector from the interface enclosure.
5. Remove the cover of the connector hole on the side of the interface enclosure.
6. Install the cover for the hole on the top of the interface enclosure.

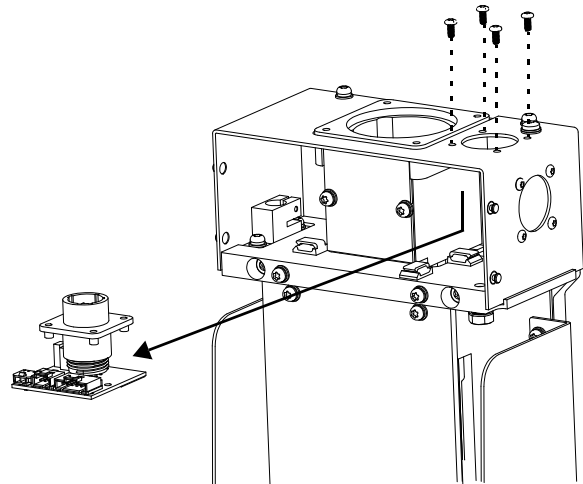

 Make sure that the flat side of the cover is on the underside of the interface enclosure.

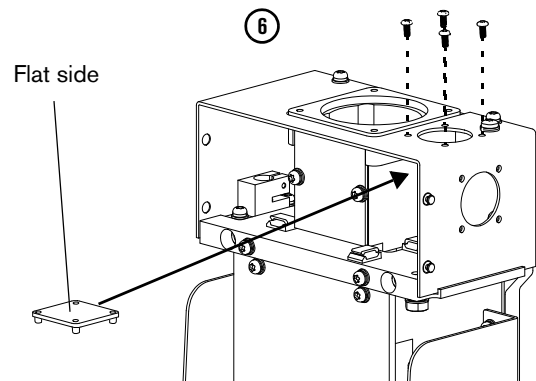
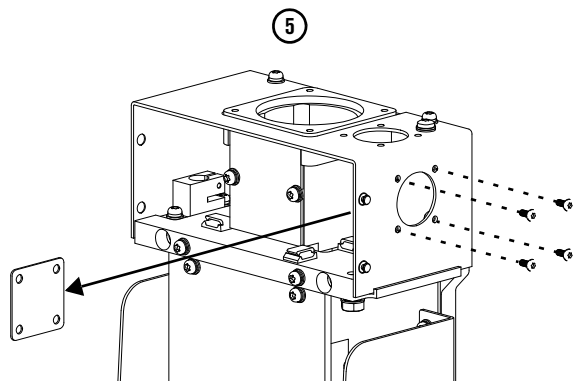

3 *Install*

7. Install the connector in the hole on the side of the interface enclosure.



Make sure that the connectors for the 3 wire harnesses point toward the front of the lifter enclosure.

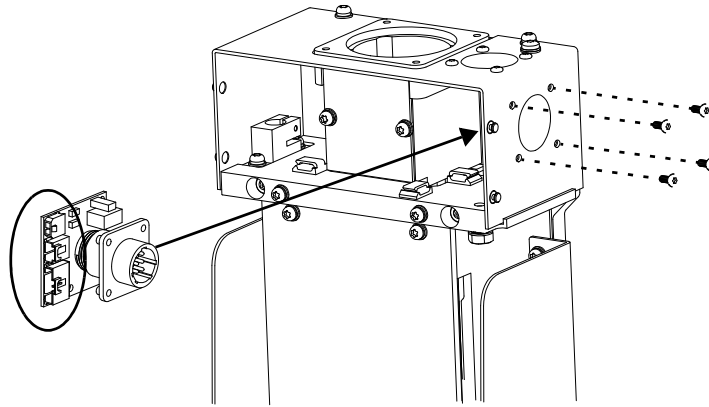

8. Connect the 3 wire harnesses to the lifter interface board.
9. Install the front panel of the interface enclosure.

Install the lifter

1. Remove the 4 screws on each side of the lifter slide.



Slide the torch mounting plate up or down as necessary to access all 4 screws on each side.

2. Remove the 2 side shields.

3. Remove the 2 side panels.

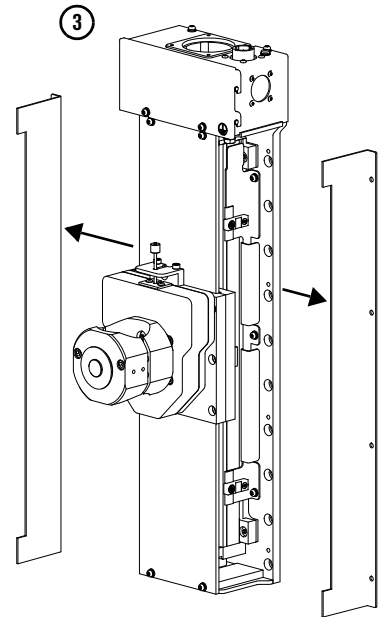
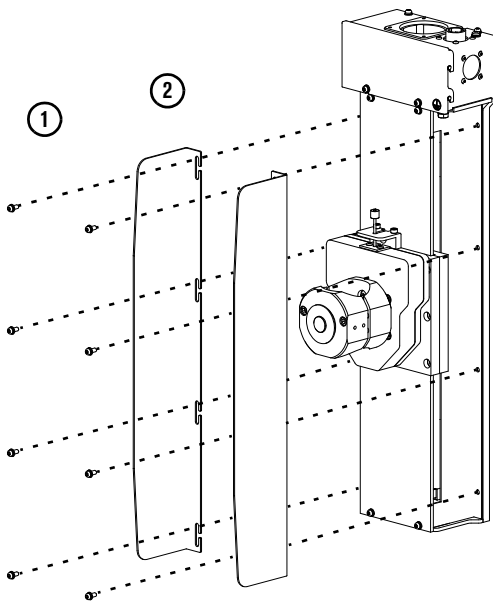

3 Install

4. Loosely tighten a minimum of four 1/4-in. or M6 socket head cap screws to attach the lifter to the gantry.
 - Make sure that the lifter is high enough that the torch does not touch the table, but low enough that the torch can touch the workpiece. The bottom of the lifter must be within 203 mm (8 in.) of the thinnest workpiece.
 - Slide the torch mounting plate up or down as necessary to access all the screw holes. If the motor is already installed on the lifter, release the brake or remove the motor so you can move the torch mounting plate.
 - Use the vertical side of the lifter to level the lifter.
 - Attach the screws in a diagonal pattern (see ①, ②, ③, ④).

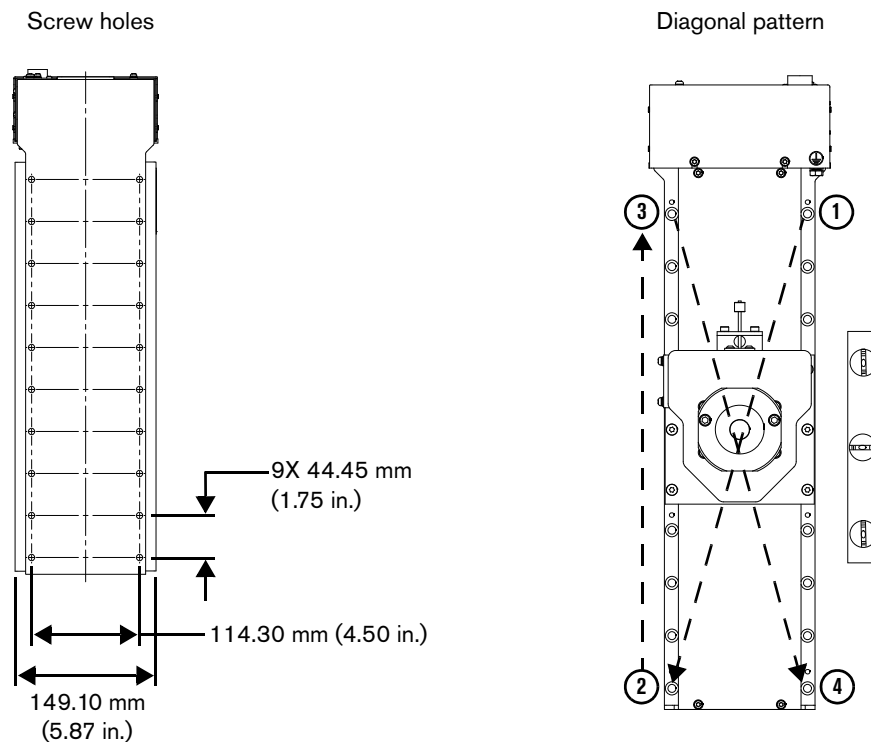

5. Tighten the screws in a diagonal pattern to a torque of 86 kg·cm (75 in·lb).
6. Install the 2 side panels and 2 side shields.

Ground the lifter



The lifter must be grounded correctly to do an accurate initial height sense (IHS).

1. Remove the M6 X 12 mm hex head bolt and 2 washers of the grounding assembly from the bottom of the enclosure.
2. Put a ground wire terminal on the hex head bolt between the 2 washers.
3. Loosely tighten the hex head bolt with the washers and terminal into the bottom of the enclosure.
4. Make sure that the terminal is in contact with both washers and the hex head bolt.
5. Tighten the hex head bolt to a torque of 51.8 kg·cm (45.0 in·lb).
6. Connect the other end of the ground wire to a terminal on the table ground bus bar on the cutting machine.
7. Make sure that the ground wire is not in the path of the lifter mechanics.

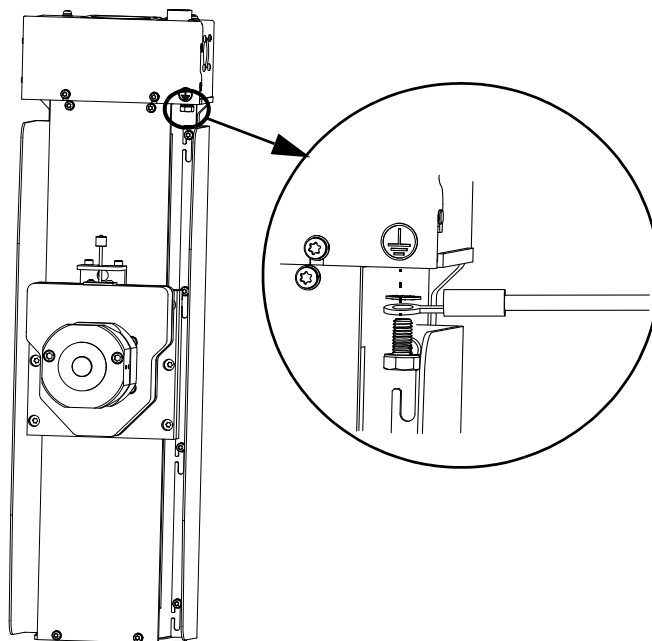

Install the THC drive

Install the THC drive into the table's drive enclosure.

Hypertherm does not offer a drive for the lifter. Select a drive that is compatible with your motor.

Install voltage divider board/VDC3

A VDC3 board (141201) supplies the necessary arc voltage feedback from the plasma power supply to the CNC. You install the VDC3 board inside the plasma power supply.

- If you have an EDGE Connect/T/TC CNC with an HPRXD plasma power supply, see the Field Service Bulletin *HPR130XD*[®], *HPR260XD*[®], and *HPR400XD*[®] *EtherCAT*[®] and *VDC3 Board Installation* (809260) for instructions.

4

Connect

Connect the lifter to the THC drive

1. Connect the motor and encoder cables from the lifter to the THC drive.
2. Connect the brake, and wire it to energize and de-energize as follows:
 - Energize when the CNC enables the THC drive
 - De-energize when the CNC disables the THC drive

3. Connect the female end of the lifter interface cable to the male connector on the lifter interface enclosure.



In the figure at right the connector for the lifter interface cable is on top of the enclosure. These instructions are the same if you moved the connector to the side of the enclosure.

4. To ground the interface cable, remove the screw and 2 washers of the cable grounding assembly from the top of the enclosure.
5. Put the ground wire terminal on the screw between the 2 washers.
6. Loosely tighten the screw with the washers and terminal into the top of the enclosure.
7. Make sure that the terminal is in contact with both washers and the screw.
8. Tighten the screw to a torque of 17.3 kg-cm (15.0 in-lb).
9. Connect the loose wires on the other end of the lifter interface cable to the I/O on your drive. See *Table 7* for the pinouts.

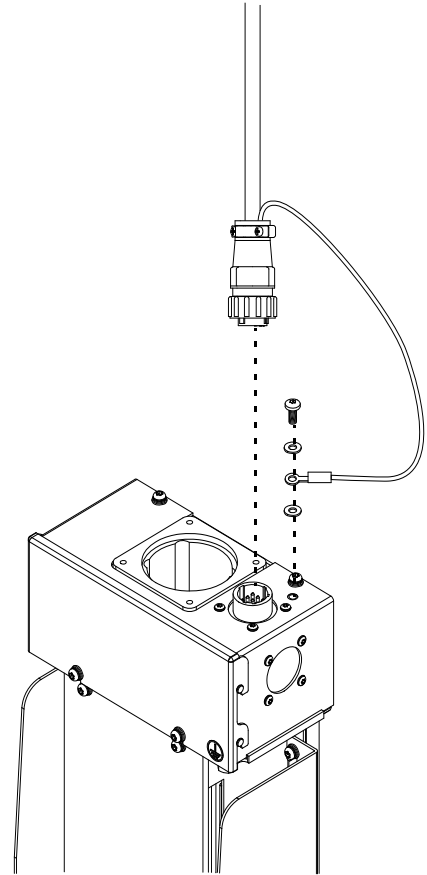

Table 7 – Pinouts for the interface cable to the drive

Pin no.	Color	Signal
1	Red	Power +24 VDC (customer supplied)
2	White	Laser pointer enable (active low)
3	White	24 VDC ground (customer supplied)
4	Orange	Torch collision input (active high)
5	White	24 VDC ground (customer supplied)
6	Black	Upper limit switch input (active high)
7	White	24 VDC ground (customer supplied)
8	Brown	Lower limit switch input (active high)
9		Not connected



The sensor signal type is PNP N/O (normally open).

Connect the THC drive to the network

Connect the THC drive to the network.

Hypertherm does not offer a drive for the lifter. Select a drive that is compatible with your motor.

Connect the VDC3 board

If you have an EDGE Connect/T/TC CNC with an HPRXD plasma power supply, see the Field Service Bulletin *HPR130XD*[®], *HPR260XD*[®], and *HPR400XD*[®] *EtherCAT*[®] and *VDC3 Board Installation* (809260) for instructions.

