

# XPR plasma

XPR<sup>®</sup> pays you back with maximum versatility, productivity, precision, and confidence.



**POWER** YOUR  
**PROFITABILITY**



# Contents

- 4 XPR® overview
- 6 Industry leading: X-Definition® cut quality
- 10 Optimized productivity and reduced operating costs
- 12 Engineered system optimization
- 14 Ease of use
- 16 Environmental benefits
- 17 Reliability
- 19 The Hypertherm Associates corporate story

# XPR overview

## Power your profitability with XPR

XPR® is the world's most **versatile** family of mechanized plasma cutters for cutting mild steel, stainless steel, and aluminum. Its flexibility improves cutting outcomes to deliver premium quality at every step, increasing **productivity** and reducing operating costs. X-Definition® technology delivers higher cut quality, thicker cutting capability, faster cutting speeds, and longer consumable life. Plus, superior part-to-part consistency over consumable life ensures the first cut is as clean as the last. XPR provides **precision** cutting on thick metal, producing parts with less dross and rework to boost productivity. Exclusive Arc Response Technology™ provides torch and ramp-down error protection that automatically intervenes in catastrophic events that can damage consumables and torches, so you can be **confident** you're protecting your investment.

**XPR pays you back with maximum versatility, productivity, precision, and confidence.**

### Widest versatility expands capabilities

- Provides superior cutting and marking versatility for mild steel, stainless steel, and aluminum with 11 different gas combinations, optimizing cutting combinations and materials
- Offers the widest range of plasma cutting power – 30 A to 460 A – on various metals and thicknesses
- Unlike fiber laser cutting, which requires pristine surfaces, plasma cutting delivers consistent, high-quality cutting on imperfect metal surfaces, including paint and rust—increasing productivity
- Compared to fiber laser cutting, the flexibility of plasma shines on robotic cutting with long leads, cutting head size, required enclosures, and higher standoff distances for complex part geometries
- Delivers weld-ready parts faster with wider, deeper, and cleaner gouge profiles. XPR automated gouging minimizes or eliminates grinding compared to carbon arc gouging — saving time and improving part quality.

### Optimized productivity drives lower operating costs

- Maximum power optimizes productivity by delivering higher cut quality, thicker cutting capability, and faster cutting speeds
  - Cut up to 12% faster compared to previous generations of plasma
  - In laboratory testing, consumable life increased by 12%
- Get cutting faster with our industry-exclusive argon-assist technology and gain a 25% increase in piercing capability, a 15% increase in edge start-cutting capability on mild steel, and a 40% increase on stainless steel compared to previous generations of plasma
- Compared to competitive systems that must switch to higher-cost gases like hydrogen for cutting thicker metals, XPR cuts with oxygen across its entire power range, decreasing costs and increasing productivity
- Exclusive Arc Response Technology™ intervenes in adverse events to preserve consumable life and prevent torch damage, extending consumable life up to 3x



Consistent cuts on mild steel, stainless steel and aluminum.

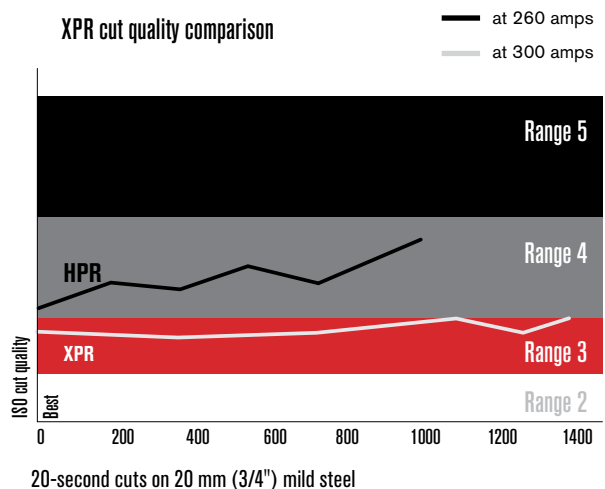

## Precision cutting reduces secondary operations

- Delivers excellent part-to-part consistency over consumable life from the first cut to the last
- Provides a smooth surface, low angularity, and minimal to no dross for clean parts off the table
- XPR embedded technology improves 45° A, V and Y bevel cut quality on thick metal, reducing weld prep time **by 50%** compared to previous generations of plasma

## Quality that instills confidence

- Hypertherm Associates delivers the industry's most innovative and reliable products
- Manufacturing design is customer-focused and goes through rigorous reliability testing
- Exclusive Arc Response Technology™ provides torch and consumables protection
- Our partner network, the best in the world, supports consumables, parts, and delivery
- Our partner network delivers system service and Tech Support, including remote support
- Training from the Hypertherm Cutting Institute and a global partner network

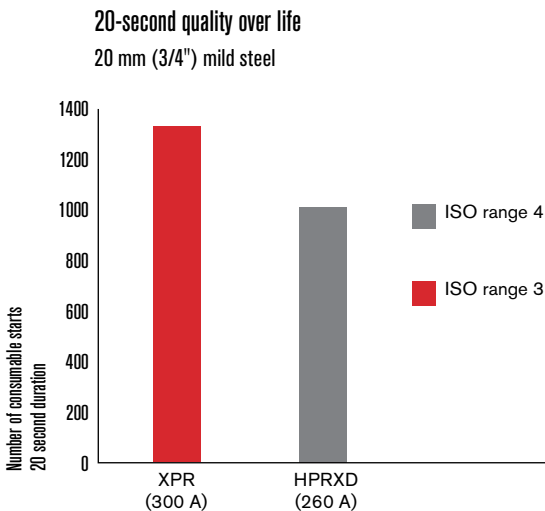

## Exclusive SureCut technology

Our exclusive SureCut™ technology uses software to automatically embed advanced cutting capabilities into the plasma cutting process, delivering improved outcomes, simplifying cutting operations, and reducing operator intervention.

- True Hole® technology—a patented process for mild steel that virtually eliminates hole taper and improves roundness—produces significantly better hole quality than what was previously possible using plasma
- True Bevel™ technology automatically applies improved bevel angle and cut sequence, increasing accuracy and quality consistency
- Rapid Part™ provides more efficient motion and skips unnecessary steps, reducing production time by up to 50%
- Plate Saver™ improves material utilization by as much as 14%, depending on the part mix when nesting square or rectangular parts



## Smart Factory

Power your profitability. Hypertherm XPR® plasma pays you back with maximum versatility, productivity, and precision. XPR includes an embedded web server for machine diagnostics and troubleshooting.

## Smart Factory capabilities

- SMART Log for preventive maintenance
- SMART Log for uptime reports (when used with EDGE)

## The value it brings

- Can automate routine tasks
- Helps improve asset management
- Can reduce errors and unplanned shutdowns
- Assists in maintenance management

# Industry leading: X-Definition cut quality

## Torch and consumable technology

X-Definition® improves cut quality and consistency on mild steel, expands the application of Hypertherm Associates' pioneering HyDefinition® process to a broad range of non-ferrous applications and greatly enhances it with a number of critical new cutting technologies.

### Expanded HyDefinition technology

Our pioneering HyDefinition technology, featuring a unique two-piece vented nozzle design, aligns and focuses the plasma arc, increasing arc stability and energy density for more consistent, precise cut quality. Previously used primarily on mild steel applications, this foundational technology is now applied to the full range of non-ferrous cutting processes for cleaner, sharper, more consistent edge quality on stainless steel and aluminum.

### Vented Water Injection (VWI)

This patent pending process features a vented N<sub>2</sub> plasma and an H<sub>2</sub>O shield. Edges are square, angularity is reduced and surface finish is excellent on stainless steel and aluminum.



### Cool nozzle

Patent pending feature on the 220 and 300-amp oxygen process provides liquid cooling directly to the nozzle bore. This cooling is a significant factor in increasing cut quality over the life of the consumables by over 40%.

Cool nozzle

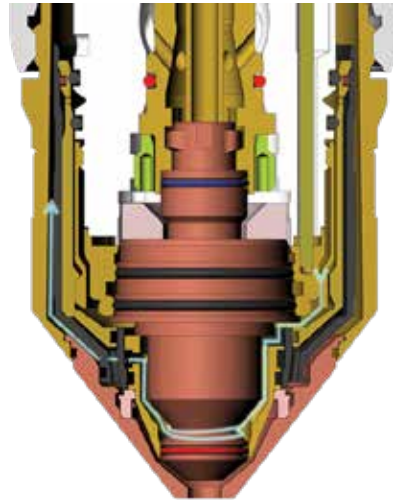

### Vent-to-shield technology

This new technology mixes hydrogen reclaimed from the vented plasma gas with the shield gas to reduce angularity and deliver more consistent edge color on stainless steel up to 12 mm (1/2").

### Plasma dampening

Patent pending plasma dampening delivers increased arc density and cut speeds on thin stainless while maintaining arc stability and smoother cut edges.

### PowerPierce

Patented **Power pierce** liquid cooled shield technology repels molten metal during piercing, allowing production piercing of 50 mm (2") on mild steel, all the way up to 64 mm (2-1/2") on mild steel on the XPR460, up to 50 mm (2") on the XPR300, and up to 40 mm (1-9/16") on the XPR170 when using **argon-assist piercing** technology.

With XPR460, in combination with argon-assist cutting technology, increases edge-starting on thick mild steel using oxygen up to 100 mm (4") on mild steel.



### Advanced arc stability

Superior arc steadiness from a modified shield gas impingement improves arc stability when coming out of a pierce hole or out of an acute angle delivering reduced lead-in lengths and improved cut quality.

### Improved torch geometry

Superior bevel capability and performance thanks to an enhanced tapered torch design that features a 76° included angle and bevel rotation of up to 52°.

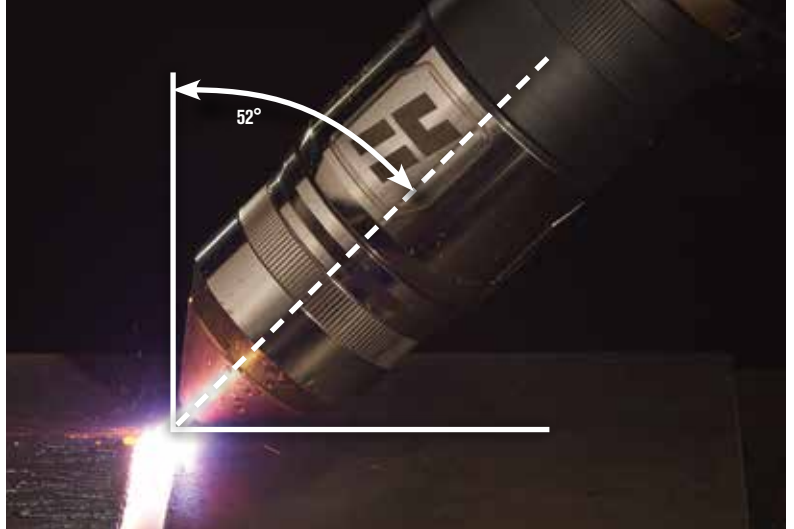

### True Hole technology

True Hole® technology incorporates new arc segmentation protocols to automatically produce bolt hole quality on mild steel with diameter to thickness ratios of 1:1 up to 2:1.



## Process control and delivery

State-of-the-art process control through a completely new concept in gas and fluid delivery. Four console options — Core™, CorePlus™, Vented Water Injection™ (VWI) and OptiMix™—offer unmatched mild steel cut quality with each console delivering successively enhanced cutting capabilities on stainless steel and aluminum. All consoles can be fully controlled through the CNC for high productivity and ease of use.

CorePlus, VWI, and Optimix gas connect consoles provide a source of argon gas which can be used for significantly improved marking and extended capacity piercing in some applications.



Gas-connect console gases/fluids				
	Core	CorePlus	Vented Water Injection (VWI)	OptiMix
O <sub>2</sub> /N <sub>2</sub> /Air	•	•	•	•
Ar		•	•	•
F <sub>5</sub> /Ar/H <sub>2</sub> O			•	•
H <sub>2</sub> -N <sub>2</sub> -Ar mixing				•



### Core™ console

Unmatched mild steel cutting performance and superior angularity and edge finish on stainless steel up to 12 mm (1/2"). This is delivered through a new N<sub>2</sub> HDi® process that prevents the mixing of air into the plasma gas, creating an improved, brighter edge finish.

### CorePlus™ console

All Core console capabilities plus argon marking and a more than 10% increase in piercing thickness with argon-assist enhanced piercing capability.

### Vented Water Injection™ (VWI) console

All Core and CorePlus console capability plus significantly enhanced stainless steel and aluminum capabilities delivered with the addition of F5 HDi processes and patented Vented Water Injection (VWI).

### OptiMix™ console

All the capabilities of the Core, CorePlus, and VWI consoles plus discrete 3-gas mixing—Ar, H<sub>2</sub>, and N<sub>2</sub>—for the world's most flexible, premium stainless steel and aluminum cutting capability.



# Optimized productivity and reduced operating costs

Building on Hypertherm Associates' industry-leading productivity technologies, XPR® delivers faster cut speeds, higher quality cuts that reduce, or eliminate secondary operations and increased consumable life with quicker set up time. These combine to further slash a plasma system's operating costs.

## Technology benefits

- A valve in the torch receptacle delivers more rapid and precise control over gas flows for significantly longer oxygen process life and a greatly accelerated ramp down process. This elimination of ramp down errors in most applications enables a consumable life span nearly 3 times longer than other systems.
- New Cool nozzle™ flow technology contributes significant consumable life increases with greater ISO range 3 results than ever before.
- Increased power provides thicker pierce capability over previous systems in a production application. Argon-assist piercing delivers enhanced piercing capabilities for occasional jobs that require thicker piercing making the XPR a more versatile and productive tool in your factory.
- High quality argon marking using the same cutting consumables allows for a rapid and efficient changeover.

		XPR170		XPR300		XPR460	
Maximum output power		35.7 kW		66.5 kW		102 kW	
100% duty arc voltage		210 V		222 V		222 V	
Cut chart thickness		mm	inches	mm	inches	mm	inches
Pierce capacity	Mild steel (argon-assist)*	40	1-9/16	50	2	64	2-1/2
	Mild steel (production)	35	1-3/8	45	1-3/4	50	2
	Stainless steel	22	7/8	38	1-1/2	64*	2-1/2*
	Aluminum	25	1	38	1-1/2	50*	2*
Severance capacity	Mild steel	60	2-3/8	80	3-1/8	100*	4*
	Stainless steel	38	1-1/2	75	3	130*	5*
	Aluminum	38	1-1/2	50	2	90	3-1/2
Cut angle	ISO 9013 range	2-4		2-4		2-4	

\*Argon-assist technology for thicker piercing and thicker severance cutting is available with CorePlus, VWI and OptiMix gas consoles

- Achieve weld-ready parts faster with wider, deeper, and cleaner gouge profiles. XPR automated gouging minimizes or eliminates grinding by 50-90% compared to carbon arc gouging – saving time and improving part quality.
- Customize gouge profiles with built in gouge processes
- A powerful arc transfer allows starting farther from the plate in any gouging orientation and access to tight gouging spaces – making it ideal for complex fabrication environments.
- Automate gouging with robots, cobots, or track-guided motion systems to reduce manual labor and increase throughput. Compared to carbon arc or low-amp plasma hand gouging, XPR delivers consistent results with less effort.

Number of 20-second starts  
20 mm (3/4") mild steel

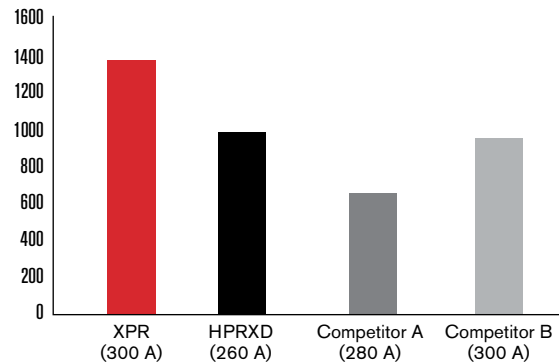

Number of 20-second starts  
12 mm (1/2") mild steel

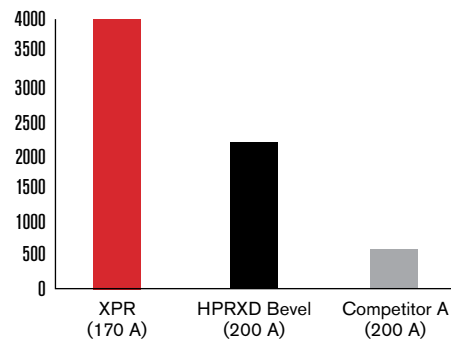

Argon marking



**POWER** YOUR  
**PROFITABILITY**





## Engineered system optimization

XPR® is engineered to deliver the highest quality cuts and optimal system performance automatically. Advanced power supply technology delivers highly responsive, rapid system feedback, and automatically intervenes to eliminate events that negatively impact system efficiency and consumable life.

### Improved operating and troubleshooting information

Sensors in the power supply deliver refined diagnostic codes and significantly enhanced system monitoring information. This reduces troubleshooting time and provides proactive system maintenance data for improved system optimization.

XPR's cutting-edge power supply features advanced chopper circuitry that instantaneously senses and responds to changes in arc voltage and current settings. This sophisticated Arc response technology™ delivers important benefits that reduce operating costs and increase productivity.

## Arc response technology™

### Automatic torch protection

The chopper module senses the onset of catastrophic electrode blowout failure and shuts down the system, protecting the torch from potential damage and enabling improved consumable utilization.

- Prevents torch failure
- Reduces operating cost

### Automatic torch protection

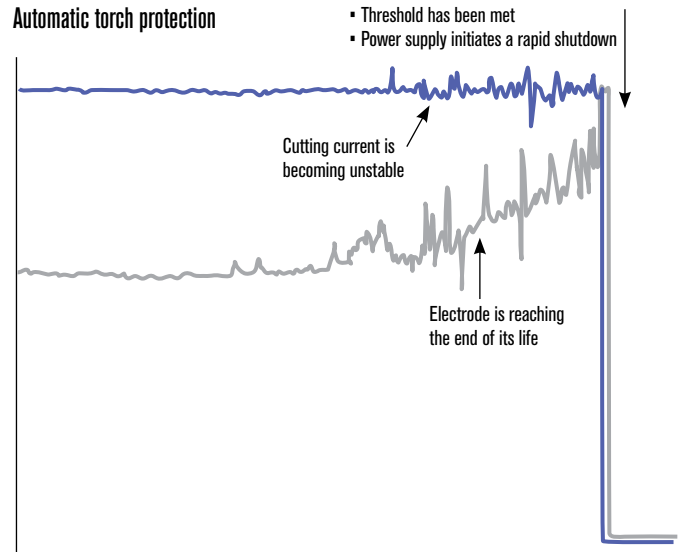

— Cutting current  
— Arc voltage  
— Plasma pressure

### Automatic ramp-down error protection

The chopper module senses when a cut is about to end in an uncontrolled manner—without proper ramp down of current and gas flow. It automatically initiates a rapid ramp-down sequence protecting the electrode, dramatically extending consumable life—over 3 times that of systems that don't have this feature.

- Protects electrode
- Improves realized consumable life
- Reduces operating cost

### Ramp-down error protection

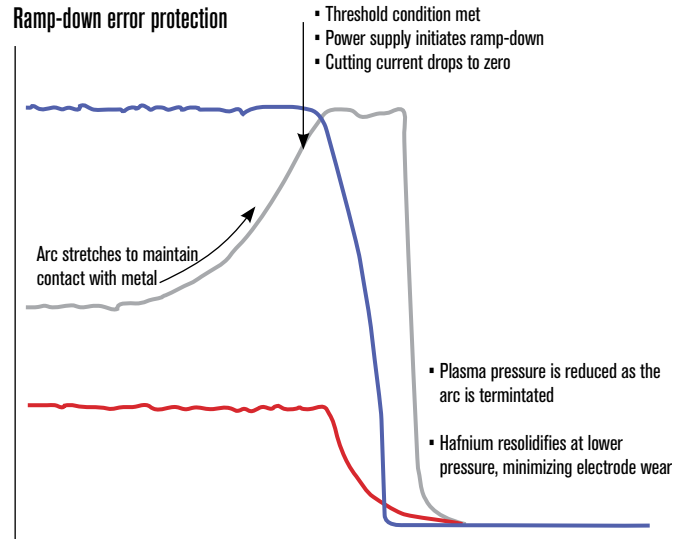

**POWER** YOUR  
**PROFITABILITY**

# POWER YOUR PROFITABILITY



## Ease of use

XPR® sets the new standard for achieving advanced system performance easily. From system set up and installation to connectivity and process optimization, XPR's intuitive operation and automatic system monitoring redefine easy plasma cutting.

- Fewer consoles and connections reduce components and complexity.
- Torch lead includes the EasyConnect™ tool-less connection to the TorchConnect™ console, reducing set up time and simplifying replacement.

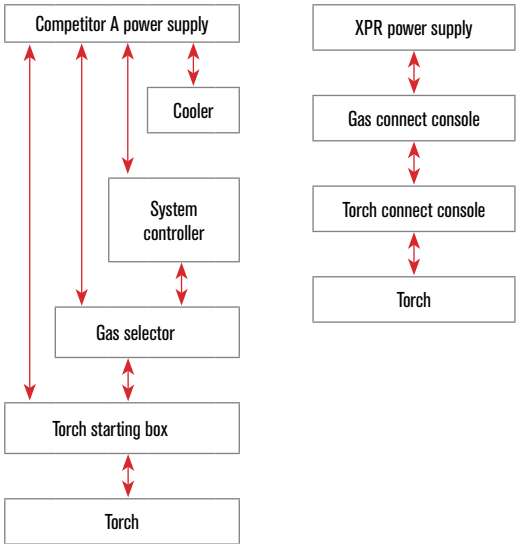

- All consoles feature advanced autogas capability enabling all cutting processes to be selected and driven directly from the CNC.
- Patented QuickLock™ electrode delivers easy ¼ turn tightening, reducing job setup time.
- Hypertherm's easiest and fastest torch disconnect design enables a rapid, one handed torch change.



- The web interface tool can be accessed via Wi-Fi and Ethernet LAN in the power supply for system monitoring and service.
- Built-in IIoT via Ethernet LAN and MTConnect® enables remote data access for smarter monitoring from anywhere in the world.
- Manual Set-Mode is ideal for straightforward applications like gouging and off-table beveling, will remember your last setup for faster repeatable workflows and simplifies set up and operations without the need for CNC/PLC integration.

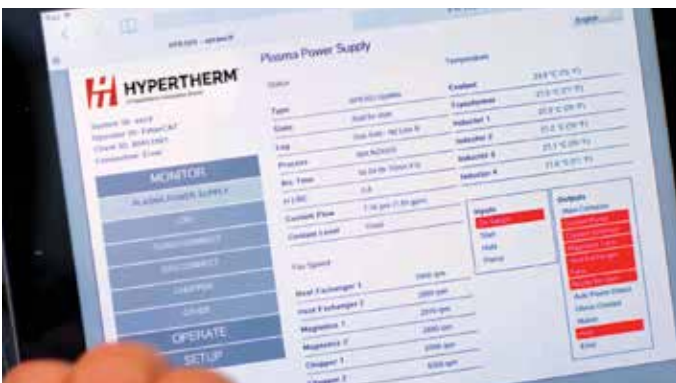

# Environmental benefits

The engineering mission at Hypertherm Associates is to develop innovative technologies, products, and solutions that provide superior value to our customers, our owners, and our planet. We consider it critical to our success to reduce the environmental impact of everything we do. The XPR systems have been designed to be more efficient and less wasteful by reducing consumable use, energy and the carbon footprint.

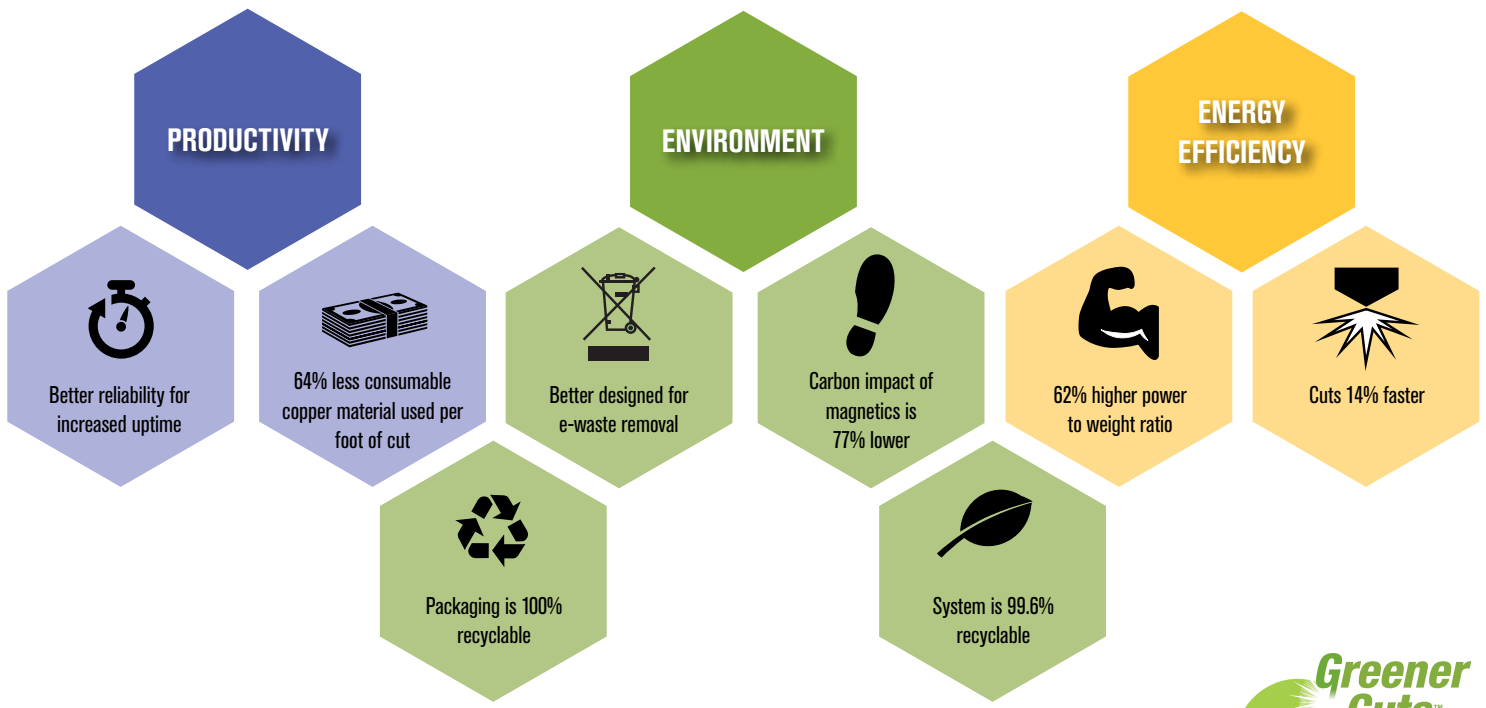

# Reliability

XPR's engineering development is the culmination of tens of thousands of hours in testing, data analysis, and system tuning. Our development optimizes your uptime ensuring reliable machine performance even under highly stressful field conditions. The XPR® is Hypertherm Associates' smartest mechanized plasma system to date. On-board sensors continually monitor current, pressure, temperature, and flow and compare to specifications during your operation to ensure optimum performance.

## Specifications

General	XPR170	XPR300	XPR460	
Maximum open-circuit voltage	360 VDC	360 VDC	360 VDC	
Maximum output current	170 A	300 A	460 A	
Maximum output power	35.7 kW	66.5 kW	102 kW	
Output voltage	50-210 VDC	50-222 VDC	50-222 VDC	
100% duty arc voltage	210 V	222 V	222 V	
Duty cycle rating	100% at 35.7 kW, 40° C (104° F)	100% at 66.5 kW, 40° C (104° F)	100% at 102 kW, 40° C (104° F)	
Operational ambient temperature range	-10° C-40° C (14° F-104° F)	-10° C-40° C (14° F-104° F)	-10° C-40° C (14° F-104° F)	
Power factor	0.98 @ 35.7 kW	0.98 @ 66.5 kW	0.98 @ 102 kW	
Cooling	Forced air (Class F)	Forced air (Class F)	Forced air (Class F)	
Insulation	Class H	Class H	Class H	
EMC emissions classification (CE models only)	Class A	Class A	Class A	
IP rating	IP21	IP21	IP21	
Unit dimensions	H =	124.8 cm (49.12")	124.8 cm (49.12")	124.8 cm (49.12")
	L =	123.8 cm (48.75")	123.8 cm (48.75")	123.8 cm (48.75")
	W =	84.2 cm (33.14")	84.2 cm (33.14")	90.5 cm (34.64")
Lift points	Top lift eye weight rating 680 kg (1,500 lb.)	Top lift eye weight rating 680 kg (1,500 lb.)	Top lift eye weight rating 680 kg (1,500 lb.)	Top lift eye weight rating 680 kg (1,500 lb.)
	Bottom lift truck slots	Bottom lift truck slots	Bottom lift truck slots	Bottom lift truck slots

Console	Cutting gases	Current (A)	Thickness (mm)	Approximate cutting speed (mm/min)	Thickness (in.)	Approximate cutting speed (ipm)
<b>Mild steel</b>						
Core, CorePlus, VWI, and OptiMix	O <sub>2</sub> plasma O <sub>2</sub> shield	30	0.5	5348	0.018	215
			3	1153	0.135	40
			5	726	3/16	30
	O <sub>2</sub> plasma Air shield	50	3	3820	0.105	155
			5	2322	3/16	95
			8	1369	5/16	55
	O <sub>2</sub> plasma Air shield	80	3	5582	0.105	225
			6	3048	1/4	110
			12	1405	1/2	55
	O <sub>2</sub> plasma Air shield	130	3	6502	0.135	240
			10	2680	3/8	110
			38	256	1-1/2	10
	O <sub>2</sub> plasma Air shield	170	6	5080	1/4	200
			12	3061	1/2	115
			25	1175	1	45
	O <sub>2</sub> plasma Air shield	220	60	152	2-3/8	6
			10	3715	3/8	150
			18	2369	5/8	110
O <sub>2</sub> plasma Air shield	300	60	158	2-1/2	6	
		12	3940	1/2	155	
		25	1950	1	75	
N <sub>2</sub> shield	300	50	560	2	21	
		80	165	3	7	
		12	4940	1/2	190	
O <sub>2</sub> plasma Air shield	460	38	1370	1-1/2	54	
		64*	540*	2-1/2*	22*	
		100*	100*	4*	4*	
<b>Stainless steel</b>						
Core, CorePlus, VWI, and OptiMix	N <sub>2</sub> plasma N <sub>2</sub> shield	40	0.8	6100	0.036	240
			3	2683	0.105	120
			6	918	1/4	32
VWI and OptiMix	F5 plasma N <sub>2</sub> shield	80	3	4248	0.135	140
			6	1916	1/4	70
			12	864	1/2	34
OptiMix	H <sub>2</sub> -Ar-N <sub>2</sub> plasma N <sub>2</sub> shield	170	10	1975	3/8	80
			12	1735	1/2	65
			38	256	1-1/2	10
		300	12	2038	1/2	80
			25	1040	1	40
			50	387	2	15
VWI and OptiMix	N <sub>2</sub> plasma H <sub>2</sub> O shield	300	75	162	3	6
			12	2159	1/2	85
			25	1302	1	50
		460	50	434	2	15
			16	2896	5/8	115
			38	1172	1-1/2	46
OptiMix	H <sub>2</sub> -Ar-N <sub>2</sub> plasma N <sub>2</sub> shield	460	60	564	2-1/2	20
			16	2322	5/8	92
			38	968	1-1/2	38
		130*	60*	587*	2-1/2*	21*
			76*	76*	5*	3*
			<b>Aluminum</b>			
Core, CorePlus, VWI, and OptiMix	Air plasma Air shield	40	1.5	4799	0.036	240
			3	2596	1/8	85
			6	911	1/4	32
VWI and OptiMix	N <sub>2</sub> plasma H <sub>2</sub> O shield	80	3	3820	1/8	140
			6	2203	1/4	80
			10	956	1/2	28
	130	6	2413	1/4	95	
		10	1702	3/8	70	
		20	870	3/4	35	
OptiMix	H <sub>2</sub> -Ar-N <sub>2</sub> plasma N <sub>2</sub> shield	300	12	2286	1/2	90
			25	1302	1	50
			50	524	2	20
VWI and OptiMix	N <sub>2</sub> plasma H <sub>2</sub> O shield	460	12	3810	1/2	150
			25	2056	1	80
			50	391	2	15
OptiMix	H <sub>2</sub> -Ar-N <sub>2</sub> plasma	460	16	3536	5/8	140
			38	1605	1-1/2	63
			50	1175	2	45
OptiMix	H <sub>2</sub> -Ar-N <sub>2</sub> plasma	460	16	5046	5/8	200
			38	2290	1-1/2	90
			50*	1810*	2*	70*
			90	300	3-1/2	12

This does not represent a complete list of processes or thicknesses that are available

\*Argon-assist technology for thicker piercing and thicker severance cutting is available with CorePlus, VWI and OptiMix gas consoles.



Constancy  
of purpose

Drive to  
innovate

Passion for  
customer  
success

# The Hypertherm Associates corporate story

Hypertherm. OMAX. Centricut. ProNest. AccuStream, Robotmaster. These names and more represent the world's leading industrial cutting technologies and solutions, and they can all be found in one company: Hypertherm Associates. With constancy of purpose, a drive to innovate, and a passion for customer success, Hypertherm Associates is leading the industrial cutting and shaping industry.

## Shaping Possibility

Since the founding of Hypertherm in 1968, we have always believed in the value of surpassing expectations. It's why we make continued investments in people. It's why we invest aggressively in ongoing product development. And now, it's why we'll be known as Hypertherm Associates: a 100% Associate-owned company composed of the world-class industrial cutting technologies and solutions you know and trust—plasma, waterjet, CAD-CAM, robotic software, and more—to help our customers succeed in ways that have never before been possible.

Hypertherm Associates builds on our legacy of challenging what's achievable with the products we create, the culture we foster, and the experience we deliver to our customers—and then goes further. Whether plasma, waterjet, or the consumables, software, and services that enable connected factories and optimized performance, the solutions that help our customers meet their business objectives can all be found in one place: Hypertherm Associates.

## Committing to Success

Behind the name Hypertherm Associates lies a fundamental commitment to the success of people: our customers, partners, our Associates, and communities. Our dedication to 100% Associate ownership is a direct result of that commitment. By maintaining complete independence from external shareholders or other corporate entities, we can focus on our customers and partners to deliver exactly what they need. And because our Associates work together moving toward a common goal, they are an energized workforce dedicated to delivering a consistently superior customer experience.

## Leading the Industry

From aerospace to agriculture and energy to infrastructure, the people, brands, and technologies of Hypertherm Associates can already be found everywhere advanced manufacturing is happening around the globe. In fact, hundreds of thousands of businesses are relying on Hypertherm Associates technologies and solutions right now for performance and reliability that help increase their productivity and profitability. And that's why companies worldwide turn to Hypertherm Associates to build ships, airplanes, and railcars, to construct steel buildings and bridges, to fabricate heavy equipment and wind turbines, and a whole lot more.

Through our portfolio of technologies and solutions, Hypertherm Associates employs more than 1,900 people and maintains operations and partner representation globally. With Hypertherm Associates, we've created a framework for growth and expansion that will allow us to bring the latest innovations to our customers more quickly, and with a deeper level of integration and customer support.

Hypertherm Associates is the evolution of a vision that continues to put our customers first, to solve their challenges, and to make it even easier to do business with us. Our global team is committed to continuously finding ways to make our company, our customers, and our communities more successful, and we're excited to have you with us as we continue our journey of shaping possibility.

# SHAPING POSSIBILITY®

PLASMA | LASER | WATERJET | AUTOMATION | SOFTWARE | CONSUMABLES

Learn more at [www.hypertherm.com/XPR](http://www.hypertherm.com/XPR)

Unless otherwise noted in the collateral, all trademarks are property of Hypertherm, Inc. and may be registered in the United States and/or other countries.

Please visit [www.hypertherm.com/patents](http://www.hypertherm.com/patents) for more details about Hypertherm Associates patent numbers and types.

© 11/2025 Hypertherm, Inc. Revision 7

897060

As 100% Associate owners, we are all focused on delivering a superior customer experience. [www.hyperthermassociates.com/ownership](http://www.hyperthermassociates.com/ownership)

Environmental stewardship is one of Hypertherm Associates' core values. [www.hyperthermassociates.com/environment](http://www.hyperthermassociates.com/environment)

100% Associate-owned

