



Powermax[®] EtherCAT[®] Interface for EDGE[®] Connect Installation and Setup Manual



810330 – REVISION 2

ENGLISH



Register your new Hypertherm system

Benefits of registration

- Safety:** Registration allows us to contact you in the unlikely event a safety or quality notification is required.
- Education:** Registration gives you free access to online product training content via the Hypertherm Cutting Institute.
- Confirmation of ownership:** Registration can serve as proof of purchase in case of an insurance loss.

Go to www.hypertherm.com/registration for easy and fast registration.

If you experience any problems with the product registration process, please contact registration@hypertherm.com.

For your records

Serial number: _____

Purchase date: _____

Distributor: _____

Maintenance notes: _____

EDGE, Powermax, SYNC, Phoenix, and Hypertherm are trademarks of Hypertherm, Inc. and may be registered in the United States and other countries. All other trademarks are the property of their respective holders.

Environmental stewardship is one of Hypertherm's core values. www.hypertherm.com/environment

© 2024 Hypertherm, Inc. 100% Associate-owned.

Powermax[®] EtherCAT[®] Interface for EDGE[®] Connect

Installation and Setup Manual

810330
REVISION 2

ENGLISH
Original instructions

June 2024

Hypertherm, Inc.
Hanover, NH 03755 USA
www.hypertherm.com

Hypertherm, Inc.

21 Great Hollow Road, P.O. Box 5010
 Hanover, NH 03755 USA
 603-643-3441 Tel (Main Office)
 603-643-5352 Fax (All Departments)
 info@hypertherm.com (Main Office)

800-643-9878 Tel (Technical Service)

technical.service@hypertherm.com (Technical Service)

800-737-2978 Tel (Customer Service)

customer.service@hypertherm.com (Customer Service)

Hypertherm México, S.A. de C.V.

52 55 5681 8109 Tel
 52 55 5681 7978 Tel
 soporte.tecnico@hypertherm.com (Technical Service)

Hypertherm Plasmatechnik GmbH

Sophie-Scholl-Platz 5
 63452 Hanau
 Germany
 00 800 33 24 97 37 Tel
 00 800 49 73 73 29 Fax

31 (0) 165 596900 Tel (Technical Service)**00 800 4973 7843 Tel (Technical Service)**

technicalservice.emeia@hypertherm.com (Technical Service)

Hypertherm (Singapore) Pte Ltd.

Solaris @ Kallang 164
 164 Kallang Way #03-13
 Singapore 349248, Republic of Singapore
 65 6841 2489 Tel
 65 6841 2490 Fax
 marketing.asia@hypertherm.com (Marketing)
 techsupportapac@hypertherm.com (Technical Service)

Hypertherm Japan Ltd.

Level 9, Edobori Center Building
 2-1-1 Edobori, Nishi-ku
 Osaka 550-0002 Japan
 81 6 6225 1183 Tel
 81 6 6225 1184 Fax
 htjapan.info@hypertherm.com (Main Office)
 techsupportapac@hypertherm.com (Technical Service)

Hypertherm Europe B.V.

Laan van Kopenhagen 100
 3317 DM Dordrecht
 Nederland
 31 165 596907 Tel
 31 165 596901 Fax
 31 165 596908 Tel (Marketing)
31 (0) 165 596900 Tel (Technical Service)
00 800 4973 7843 Tel (Technical Service)
 technicalservice.emeia@hypertherm.com (Technical Service)

Hypertherm (Shanghai) Trading Co., Ltd.

B301, 495 ShangZhong Road
 Shanghai, 200231
 PR China
 86-21-80231122 Tel
 86-21-80231120 Fax

86-21-80231128 Tel (Technical Service)

techsupport.china@hypertherm.com (Technical Service)

South America & Central America: Hypertherm Brasil Ltda.

Rua Bras Cubas, 231 – Jardim Maia
 Guarulhos, SP – Brasil
 CEP 07115-030
 55 11 2409 2636 Tel
 tecnico.sa@hypertherm.com (Technical Service)

Hypertherm Korea Branch

#3904. APEC-ro 17. Heaundae-gu. Busan.
 Korea 48060
 82 (0)51 747 0358 Tel
 82 (0)51 701 0358 Fax
 marketing.korea@hypertherm.com (Marketing)
 techsupportapac@hypertherm.com (Technical Service)

Hypertherm Pty Limited

GPO Box 4836
 Sydney NSW 2001, Australia
 61 7 3103 1695 Tel
 61 7 3219 9010 Fax
 au.sales@hypertherm.com (Main Office)
 techsupportapac@hypertherm.com (Technical Service)

Hypertherm (India) Thermal Cutting Pvt. Ltd

A-18 / B-1 Extension,
 Mohan Co-Operative Industrial Estate,
 Mathura Road, New Delhi 110044, India
 91-11-40521201/ 2/ 3 Tel
 91-11 40521204 Fax
 htindia.info@hypertherm.com (Main Office)
 technicalservice.emeia@hypertherm.com (Technical Service)



For training and education resources, go to the Hypertherm Cutting Institute (HCI) online at www.hypertherm.com/hci.

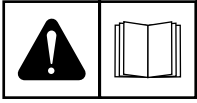

ENGLISH

WARNING! Before operating any Hypertherm equipment, read the safety instructions in your product's manual, the *Safety and Compliance Manual* (80669C), *Waterjet Safety and Compliance Manual* (80943C), and *Radio Frequency Warning Manual* (80945C). Failure to follow safety instructions can result in personal injury or in damage to equipment.

Copies of the manuals can come with the product in electronic and printed formats. Electronic copies are also on our website. Many manuals are available in multiple languages at www.hypertherm.com/docs.

BG (БЪЛГАРСКИ/BULGARIAN)

ПРЕДУПРЕЖДЕНИЕ! Преди да работите с което и да е оборудване Hypertherm, прочетете инструкциите за безопасност в ръководството на вашия продукт, „Инструкция за безопасност и съответствие“ (80669C), „Инструкция за безопасност и съответствие на Waterjet“ (80943C) и „Инструкция за предупреждение за радиочестота“ (80945C).

Продуктът може да е съпроводен от копия на ръководствата в електронен и в печатен формат. Тези в електронен формат са достъпни също на уебсайта ни. Много ръководства са налице на няколко езика на адрес www.hypertherm.com/docs.

CS (ČESKY/CZECH)

VAROVÁNÍ! Před uvedením jakéhokoli zařízení Hypertherm do provozu si přečtěte bezpečnostní pokyny v příručce k produktu a v *Manuálu pro bezpečnost a dodržování předpisů* (80669C), *Manuálu pro bezpečnost a dodržování předpisů při řezání vodním paprskem* (80943C) a *Manuálu varování ohledně rádiových frekvencí* (80945C).

Kopie příruček mohou být součástí dodávky produktu, a to v elektronické i tištěné formě. Elektronické kopie jsou k dispozici i na našich webových stránkách. Mnoho příruček je k dispozici v různých jazycích na stránce www.hypertherm.com/docs.

DA (DANSK/DANISH)

ADVARSEL! Inden Hypertherm udstyr tages i brug skal sikkerhedsinstruktionerne i produktets manual og i *Manual om sikkerhed og overholdelse af krav* (80669C), *Manual om sikkerhed og overholdelse af krav for vandstråleskæring* (80943C), og *Manual om radiofrekvensadvarsel* (80945C), gennemlæses.

Kopier af manualerne kan leveres med produktet i elektronisk og trykt format. Elektroniske kopier findes også på vores hjemmeside. Mange manualer er tilgængelige på flere sprog på www.hypertherm.com/docs.

DE (DEUTSCH/GERMAN)

WARNUNG! Bevor Sie ein Hypertherm-Gerät in Betrieb nehmen, lesen Sie bitte die Sicherheitsanweisungen in Ihrer Bedienungsanleitung, das *Handbuch für Sicherheit und Übereinstimmung* (80669C), das *Handbuch für Sicherheit und Compliance bei Wasserstrahl-Schneidanlagen* (80943C) und das *Handbuch für Hochfrequenz-Warnung* (80945C).

Bedienungsanleitungen und Handbücher können dem Gerät in elektronischer Form oder als Druckversion beiliegen. In elektronischer Form liegen sie auch auf unserer Website vor. Viele Handbücher stehen in verschiedenen Sprachen auf www.hypertherm.com/docs zur Verfügung.

ES (ESPAÑOL/SPANISH)

¡ADVERTENCIA! Antes de operar cualquier equipo Hypertherm, lea las instrucciones de seguridad del manual de su producto, del *Manual de seguridad y cumplimiento* (80669C), del *Manual de seguridad y cumplimiento en corte con chorro de agua* (80943C) y del *Manual de advertencias de radiofrecuencia* (80945C).

El producto puede incluir copias de los manuales en formato digital e impreso. Las copias digitales también están en nuestra página web. Hay diversos manuales disponibles en varios idiomas en www.hypertherm.com/docs.

ET (EESTI/ESTONIAN)

HOIATUS! Enne Hyperthermi mis tahes seadme kasutamist lugege läbi toote kasutusjuhendis olevad ohutusjuhised ning *Ohutus- ja vastavusjuhend* (80669C), *Veejõa ohutuse ja vastavuse juhend* (80943C) ja *Raadiosageduse hoiatusjuhend* (80945C). Ohutusjuhiste eiramine võib põhjustada vigastusi ja kahjustada seadmeid.

Juhiste koopiad võivad tootega kaasas olla elektrooniliselt või trükituna. Elektroonilised koopiad on saadaval ka meie veebilehel. Paljud kasutusjuhendid on erinevates keeltes saadaval veebilehel www.hypertherm.com/docs.

FI (SUOMI/FINNISH)

VAROITUS! Ennen minkään Hypertherm-laitteen käyttöä lue tuotteen käyttöoppaassa olevat turvallisuusohjeet, *turvallisuuden ja vaatimustenmukaisuuden käsikirja* (80669C), *vesileikkauksen turvallisuuden ja vaatimustenmukaisuuden käsikirja* (80943C) ja *radiotaajuusvaroitusten käsikirja* (80945C).

Käyttöoppaiden kopiot voivat olla tuotteen mukana sähköisessä ja tulostetussa muodossa. Sähköiset kopiot ovat myös verkkosivustollamme. Monet käyttöoppaat ovat myös saatavissa useilla kielillä www.hypertherm.com/docs.

FR (FRANÇAIS/FRENCH)

AVERTISSEMENT! Avant d'utiliser tout équipement Hypertherm, lire les consignes de sécurité du manuel de votre produit, du *Manuel de sécurité et de conformité* (80669C), du *Manuel de sécurité et de conformité du jet d'eau* (80943C) et du *Manuel d'avertissement relatif aux radiofréquences* (80945C).

Les exemplaires des manuels qui accompagnent le produit peuvent être sous forme électronique ou papier. Les manuels sous forme électronique se trouvent également sur notre site Internet. Plusieurs manuels sont offerts en plusieurs langues à www.hypertherm.com/docs.

GR (ΕΛΛΗΝΙΚΑ/GREEK)

ΠΡΟΕΙΔΟΠΟΙΗΣΗ! Πριν θέσετε σε λειτουργία οποιονδήποτε εξοπλισμό της Hypertherm, διαβάστε τις οδηγίες ασφαλείας στο εγχειρίδιο του προϊόντος και στο *εγχειρίδιο ασφαλείας και συμμόρφωσης* (80669C), στο *εγχειρίδιο ασφαλείας και συμμόρφωσης του waterjet* (80943C) και στο *εγχειρίδιο προειδοποιήσεων για τις ραδιοσυχνότητες* (80945C).

Το προϊόν μπορεί να συνοδεύεται από αντίγραφα των εγχειριδίων σε ηλεκτρονική και έντυπη μορφή. Τα ηλεκτρονικά αντίγραφα υπάρχουν επίσης στον ιστότοπό μας. Πολλά εγχειρίδια είναι διαθέσιμα σε διάφορες γλώσσες στο www.hypertherm.com/docs.

HU (MAGYAR/HUNGARIAN)

VIGYÁZAT! Mielőtt bármilyen Hypertherm berendezést üzemeltetne, olvassa el a biztonsági információkat a termék kézikönyvében, a *Biztonsági és szabálykövetési kézikönyvben* (80669C), a *Vízugaras biztonsági és szabálykövetési kézikönyvben* (80943C) és a *Rádiófrekvenciás figyelmeztetéseket tartalmazó kézikönyvben* (80945C).

A termékhez a kézikönyv példányai elektronikus és nyomtatott formában is mellékelve lehetnek. Az elektronikus példányok webhelyünkön is megtalálhatók. Számos kézikönyv áll rendelkezésre több nyelven a www.hypertherm.com/docs weboldalon.

ID (BAHASA INDONESIA/INDONESIAN)

PERINGATAN! Sebelum mengoperasikan peralatan Hypertherm, bacalah petunjuk keselamatan dalam manual produk Anda, *Manual Keselamatan dan Kepatuhan* (80669C), *Manual Keselamatan dan Kepatuhan Jet Air* (80943C), dan *Manual Peringatan Frekuensi Radio* (80945C). Kegagalan mengikuti petunjuk keselamatan dapat menyebabkan cedera pribadi atau kerusakan pada peralatan.

Produk mungkin disertai salinan manual atau petunjuk dalam format elektronik maupun cetak. Salinan elektronik juga tersedia di situs web kami. Berbagai manual tersedia dalam beberapa bahasa di www.hypertherm.com/docs.

IT (ITALIANO/ITALIAN)

AVVERTENZA! Prima di usare un'attrezzatura Hypertherm, leggere le istruzioni sulla sicurezza nel manuale del prodotto, nel *Manuale sulla sicurezza e la conformità* (80669C), nel *Manuale sulla sicurezza e la conformità Waterjet* (80943C) e nel *Manuale di avvertenze sulla radiofrequenza* (80945C).

Copie del manuale possono accompagnare il prodotto in formato cartaceo o elettronico. Le copie elettroniche sono disponibili anche sul nostro sito web. Molti manuali sono disponibili in diverse lingue all'indirizzo www.hypertherm.com/docs.

JA (日本語/JAPANESE)

警告! Hypertherm 機器を操作する前に、この製品説明書にある安全情報、「安全とコンプライアンスマニュアル」(80669C)、「ウォータージェット的安全とコンプライアンス」(80943C)、「高周波警告」(80945C)をお読みください。

説明書のコピーは、電子フォーマット、または印刷物として製品に同梱されています。電子コピーは当社ウェブサイトにも掲載されています。説明書の多くは www.hypertherm.com/docs にて複数の言語でご用意しています。

KO (한국어/KOREAN)

경고! Hypertherm 장비를 사용하기 전에 제품 설명서와 안전 및 규정 준수 설명서(80669C), 워터젯 안전 및 규정 준수 설명서(80943C) 그리고 무선 주파수 경고 설명서(80945C)에 나와 있는 안전 지침을 읽으십시오.

전자 형식과 인쇄된 형식으로 설명서 사본이 제품과 함께 제공될 수 있습니다. 전자 사본도 Hypertherm 웹사이트에서 보실 수 있으며 설명서 사본은 www.hypertherm.com/docs 에서 여러 언어로 제공됩니다.

NE (NEDERLANDS/DUTCH)

WAARSCHUWING! Lees voordat u Hypertherm-apparaat gebruikt de veiligheidsinstructies in de producthandleiding, in de *Veiligheids- en nalevingshandleiding* (80669C) in de *Veiligheids- en nalevingshandleiding voor waterstralen* (80943C) en in de *Waarschuwingshandleiding radiofrequentie* (80945C).

De handleidingen kunnen in elektronische en gedrukte vorm met het product worden meegeleverd. Elektronische versies zijn ook beschikbaar op onze website. Veel handleidingen zijn in meerdere talen beschikbaar via www.hypertherm.com/docs.

NO (NORSK/NORWEGIAN)

ADVARSEL! Før du bruker noe Hypertherm-utstyr, må du lese sikkerhetsinstruksjonene i produktets håndbok, *håndboken om sikkerhet og samsvar* (80669C), *håndboken om vannjet sikkerhet og samsvar* (80943C), og *håndboken om radiofrekvensadvarslere* (80945C).

Eksemplarer av håndbøkene kan følge med produktet i elektronisk og trykt form. Elektroniske eksemplarer finnes også på nettstedet vårt. Mange håndbøker er tilgjengelig i flere språk på www.hypertherm.com/docs.

PL (POLSKI/POLISH)

OSTRZEŻENIE! Przed rozpoczęciem obsługi jakiegokolwiek systemu firmy Hypertherm należy się zapoznać z instrukcjami bezpieczeństwa zamieszczonymi w podręczniku produktu, w *podręczniku bezpieczeństwa i zgodności* (80669C), *podręczniku bezpieczeństwa i zgodności systemów strumienia wody* (80943C) oraz *podręczniku z ostrzeżeniem o częstotliwości radiowej* (80945C).

Do produktu mogą być dołączone podręczniki użytkownika w formie elektronicznej i drukowanej. Kopie elektroniczne znajdują się również w naszej witrynie internetowej. Wiele podręczników jest dostępnych w różnych językach pod adresem www.hypertherm.com/docs.

PT (PORTUGUÊS/PORTUGUESE)

ADVERTÊNCIA! Antes de operar qualquer equipamento Hypertherm, leia as instruções de segurança no manual do seu produto, no *Manual de Segurança e de Conformidade* (80669C), no *Manual de Segurança e de Conformidade do Waterjet* (80943C) e no *Manual de Advertência de radiofrequência* (80945C).

Cópias dos manuais podem vir com o produto nos formatos eletrônico e impresso. Cópias eletrônicas também são encontradas em nosso website. Muitos manuais estão disponíveis em vários idiomas em www.hypertherm.com/docs.

RO (ROMÂNĂ/ROMANIAN)

AVERTIZARE! Înainte de utilizarea oricărei echipament Hypertherm, citiți instrucțiunile de siguranță din manualul produsului, *manualul de siguranță și conformitate* (80669C), *manualul de siguranță și conformitate Waterjet* (80943C) și din *manualul de avertizare privind radiofrecvența* (80945C).

Produsul poate fi însoțit de copii ale manualelor în format tipărit și electronic. Exemplarele electronice sunt disponibile și pe site-ul nostru web. Numeroase manuale sunt disponibile în mai mult limbi la adresa: www.hypertherm.com/docs.

RU (РУССКИЙ/RUSSIAN)

БЕРЕГИСЬ! Перед работой с любым оборудованием Hypertherm ознакомьтесь с инструкциями по безопасности, представленными в руководстве, которое поставляется вместе с продуктом, в *Руководстве по безопасности и соответствию* (80669C), в *Руководстве по безопасности и соответствию для водоструйной резки* (80943C) и *Руководстве по предупреждению о радиочастотном излучении* (80945C).

Копии руководств, которые поставляются вместе с продуктом, могут быть представлены в электронном и бумажном виде. Электронные копии также доступны на нашем веб-сайте. Целый ряд руководств доступны на нескольких языках по ссылке www.hypertherm.com/docs.

SK (SLOVENČINA/SLOVAK)

VÝSTRAHA! Pred použitím akéhokoľvek zariadenia od spoločnosti Hypertherm si prečítajte bezpečnostné pokyny v návode na obsluhu vášho zariadenia a v *Manuáli o bezpečnosti a súlade s normami* (80669C), *Manuáli o bezpečnosti a súlade s normami pre systém rezania vodou* (80943C) a v *Manuáli s informáciami o rádiových frekvenciách* (80945C).

Návod na obsluhu sa dodáva spolu s produktom v elektronickej a tlačenej podobe. Jeho elektronickej formát je dostupný aj na našej webovej stránke. Mnohé z návodov na obsluhu sú dostupné vo viaczjazyčnej mutácii na stránke www.hypertherm.com/docs.

SL (SLOVENŠČINA/SLOVENIAN)

OPOZORILO! Pred uporabo katerekoli Hyperthermove opreme preberite varnostna navodila v priročniku vašega izdelka, v *Priročniku za varnost in skladnost* (80669C), v *Priročniku za varnost in skladnost sistemov rezanja z vodnim curkom* (80943C) in v *Priročniku Opozorilo o radijskih frekvencah* (80945C).

Izvodi priročnikov so lahko izdelku priloženi v elektronski in tiskani obliki. Elektronski izvodi so na voljo tudi na našem spletnem mestu. Številni priročniki so na voljo v različnih jezikih na naslovu www.hypertherm.com/docs.

SR (SRPSKI/SERBIAN)

UPOZORENJE! Pre rukovanja bilo kojom Hyperthermovom opremom pročitajte uputstva o bezbednosti u svom priručniku za proizvod, *Priručniku o bezbednosti i usaglašenosti* (80669C), *Priručniku o bezbednosti i usaglašenosti Waterjet tehnologije* (80943C) i *Priručniku sa upozorenjem o radio-frekvenciji* (80945C).

Уз производ се испоручују копије приручника у електронском или штампаном формату. Електронске копије су такође доступне на нашем веб-сајту. Многи приручници су доступни на више језика на адреси www.hypertherm.com/docs.

SV (SVENSKA/SWEDISH)

VARNING! Läs häftet säkerhetsinformationen i din produkts *säkerhets- och efterlevnadsmanual* (80669C), *säkerhets- och efterlevnadsmanualen för Waterjet* (80943C) och *varningsmanualen för radiofrekvenser* (80945C) för viktig säkerhetsinformation innan du använder eller underhåller Hypertherm-utrustning. Kopior av manualerna kan medfölja produkten i elektroniskt och tryckt format. Elektroniska kopior finns också på vår webbplats. Många manualer finns på flera språk på www.hypertherm.com/docs.

TH (ภาษาไทย/THAI)

คำเตือน! ก่อนการใช้งานอุปกรณ์ของ Hypertherm ทั้งหมด โปรดอ่านคำแนะนำด้านความปลอดภัยในคู่มือการใช้สินค้า คู่มือด้านความปลอดภัยและการปฏิบัติตาม (80669C), คู่มือด้านความปลอดภัยและการปฏิบัติตามสำหรับการใช้หัวตัดระบบวอเตอร์เจ็ต (80943C) และ คู่มือคำเตือนเกี่ยวกับความถี่วิทยุ (80945C) การไม่ปฏิบัติตามคำแนะนำด้านความปลอดภัยอาจส่งผลให้เกิดการบาดเจ็บหรือเกิดความเสียหายต่ออุปกรณ์
สำเนาคู่มือทั้งในรูปแบบอิเล็กทรอนิกส์และแบบสิ่งพิมพ์จะถูกแนบมาพร้อมกับผลิตภัณฑ์ สำหรับสำเนาคู่มือในรูปแบบอิเล็กทรอนิกส์ของผลิตภัณฑ์และสำเนาคู่มือต่างๆ ในหลากหลายภาษาอื่นยังมีให้บริการบนเว็บไซต์ www.hypertherm.com/docs ของเรอีกด้วย

TR (TÜRKÇE/TURKISH)

UYARI! Bir Hypertherm ekipmanını çalıştırmadan önce, ürününüzün kullanım kılavuzunda, *Güvenlik ve Uyumluluk Kılavuzu'nda* (80669C), *Su Jeti Güvenlik ve Uyumluluk Kılavuzu'nda* (80943C) ve *Radyo Frekansı Uyarısı Kılavuzu'nda* (80945C) yer alan güvenlik talimatlarını okuyun.

Kılavuzların kopyaları, elektronik ve basılı formatta ürüne birlikte verilebilir. Elektronik kopyalar web sitemizde de yer alır. Kılavuzların birçokğu www.hypertherm.com/docs adresinde birçok dilde mevcuttur.

VI (TIẾNG VIỆT/VIETNAMESE)

CẢNH BÁO! Trước khi vận hành bất kỳ thiết bị Hypertherm nào, hãy đọc các hướng dẫn an toàn trong hướng dẫn sử dụng sản phẩm của bạn, *Sổ tay An toàn và Tuân thủ* (80669C), *Sổ tay An toàn và Tuân thủ Tia nước* (80943C), và *Hướng dẫn Cảnh báo Tần số Vô tuyến* (80945C). Không tuân thủ các hướng dẫn an toàn có thể dẫn đến thương tích cá nhân hoặc hư hỏng thiết bị.

Bản sao của sổ tay có thể đi kèm với sản phẩm ở định dạng điện tử và in. Bản điện tử cũng có trên trang web của chúng tôi. Nhiều sổ tay có sẵn bằng nhiều ngôn ngữ tại www.hypertherm.com/docs.

ZH-CN (简体中文/CHINESE SIMPLIFIED)

警告! 在操作任何海宝设备之前, 请阅读产品手册、《安全和法规遵守手册》(80669C)、《水射流安全和法规遵守手册》(80943C) 以及《射频警告手册》(80945C) 中的安全操作说明。

随产品提供的手册可提供电子版和印刷版两种格式。电子版本同时也在我们的网站上提供。很多手册有多种语言版本, 详见 www.hypertherm.com/docs。

ZH-TW (繁體中文/CHINESE TRADITIONAL)

警告! 在操作任何 Hypertherm 設備前, 請先閱讀您產品手冊內的安全指示, 包括《安全和法規遵從手冊》(80669C)、《水刀安全和法規遵從手冊》(80943C), 以及《無線電頻率警示訊號手冊》(80945C)。

電子版和印刷版手冊複本可能隨產品附上。您也可以前往我們的網站下載電子版手冊。我們的網站上還以多種語言形式提供多種手冊, 請造訪 www.hypertherm.com/docs。

Contents

Electromagnetic Compatibility (EMC)	5
Warranty	7
Introduction.....	9
Purpose	9
Necessary tools and materials	9
Kit 429010 contents.....	10
Cables and wires	12
Cables available from Hypertherm	13
External RS-485 serial interface cables	13
External machine interface cables.....	13
External EtherCAT cables.....	14
Ohmic contact wire	14
Additional cables and wires (customer-supplied).....	15
Machine interface receptacle with internal cables and voltage divider PCB	15
Installation positions and dimensions.....	16
Installation positions	16
Dimensions for position 1*	17
Dimensions for positions 2 and 3*	17
Before you begin	18
Installation task overview.....	19
Attach the strain relief bracket	19
Attach the installation brackets.....	20
Position 1	20
Position 2 and 3	20
Attach the Powermax EtherCAT Interface.....	21

Contents

Connect the cables and wires 21

 Connect the EtherCAT cable 22

 Connect the Powermax EtherCAT Interface to the Powermax plasma supply 23

 Connect the machine interface cable..... 23

 Connect the RS-485 serial interface cable..... 23

 Connect the ohmic contact and work lead connection wires 24

 Connect the EMI ground cable 25

 Supply electrical power 25

Configure the EtherCAT® network..... 25

Monitor the status of inputs and outputs..... 26

Electromagnetic Compatibility (EMC)

Introduction

Hypertherm's CE-marked equipment is built in compliance with standard EN60974-10. The equipment should be installed and used in accordance with the information below to achieve electromagnetic compatibility.

The limits required by EN60974-10 may not be adequate to completely eliminate interference when the affected equipment is in close proximity or has a high degree of sensitivity. In such cases it may be necessary to use other measures to further reduce interference.

This cutting equipment is designed for use only in an industrial environment.

Installation and use

The user is responsible for installing and using the plasma equipment according to the manufacturer's instructions.

If electromagnetic disturbances are detected then it shall be the responsibility of the user to resolve the situation with the technical assistance of the manufacturer. In some cases this remedial action may be as simple as earthing the cutting circuit, see *Earthing of the workpiece*. In other cases, it could involve constructing an electromagnetic screen enclosing the power source and the work complete with associated input filters. In all cases, electromagnetic disturbances must be reduced to the point where they are no longer troublesome.

Assessment of area

Before installing the equipment, the user shall make an assessment of potential electromagnetic problems in the surrounding area. The following shall be taken into account:

- a. Other supply cables, control cables, signaling and telephone cables; above, below and adjacent to the cutting equipment.
- b. Radio and television transmitters and receivers.
- c. Computer and other control equipment.
- d. Safety critical equipment, for example guarding of industrial equipment.
- e. Health of the people around, for example the use of pacemakers and hearing aids.
- f. Equipment used for calibration or measurement.
- g. Immunity of other equipment in the environment. User shall ensure that other equipment being used in the environment is compatible. This may require additional protection measures.
- h. Time of day that cutting or other activities are to be carried out.

The size of the surrounding area to be considered will depend on the structure of the building and other activities that are taking place. The surrounding area may extend beyond the boundaries of the premises.

Methods of reducing emissions

Mains supply

Cutting equipment must be connected to the mains supply according to the manufacturer's recommendations. If interference occurs, it may be necessary to take additional precautions such as filtering of the mains supply.

Consideration should be given to shielding the supply cable of permanently installed cutting equipment, in metallic conduit or equivalent. Shielding should be electrically continuous throughout its length. The shielding should be connected to the cutting mains supply so that good electrical contact is maintained between the conduit and the cutting power source enclosure.

Maintenance of cutting equipment

The cutting equipment must be routinely maintained according to the manufacturer's recommendations. All access and service doors and covers should be closed and properly fastened when the cutting equipment is in operation. The cutting equipment should not be modified in any way, except as set forth in and in accordance with the manufacturer's written instructions. For example, the spark gaps of arc striking and stabilizing devices should be adjusted and maintained according to the manufacturer's recommendations.

Cutting cables

The cutting cables should be kept as short as possible and should be positioned close together, running at or close to the floor level.

Equipotential bonding

Bonding of all metallic components in the cutting installation and adjacent to it should be considered.

However, metallic components bonded to the workpiece will increase the risk that the operator could receive a shock by touching these metallic components and the electrode (nozzle for laser heads) at the same time.

The operator should be insulated from all such bonded metallic components.

Electromagnetic Compatibility (EMC)

Earthing of the workpiece

Where the workpiece is not bonded to earth for electrical safety, nor connected to earth because of its size and position, for example, ship's hull or building steel work, a connection bonding the workpiece to earth may reduce emissions in some, but not all instances. Care should be taken to prevent the earthing of the workpiece increasing the risk of injury to users, or damage to other electrical equipment. Where necessary, the connection of the workpiece to earth should be made by a direct connection to the workpiece, but in some countries where direct connection is not permitted, the bonding should be achieved by suitable capacitances selected according to national regulations.

Note: The cutting circuit may or may not be earthed for safety reasons. Changing the earthing arrangements should only be authorized by a person who is competent to assess whether the changes will increase the risk of injury, for example, by allowing parallel cutting current return paths which may damage the earth circuits of other equipment. Further guidance is provided in IEC 60974-9, Arc Welding Equipment, Part 9: Installation and Use.

Screening and shielding

Selective screening and shielding of other cables and equipment in the surrounding area may alleviate problems of interference. Screening of the entire plasma cutting installation may be considered for special applications.

Attention

Genuine Hypertherm parts are the factory-recommended replacement parts for your Hypertherm system. Any damage or injury caused by the use of other than genuine Hypertherm parts may not be covered by the Hypertherm warranty, and will constitute misuse of the Hypertherm Product.

You are solely responsible for the safe use of the Product. Hypertherm does not and cannot make any guarantee or warranty regarding the safe use of the product in your environment.

General

Hypertherm, Inc. warrants that its Products shall be free from defects in materials and workmanship for the specific periods of time set forth herein and as follows: if Hypertherm is notified of a defect (i) with respect to the plasma power supply within a period of two (2) years from the date of its delivery to you, with the exception of Powermax brand power supplies, which shall be within a period of three (3) years from the date of delivery to you, and (ii) with respect to the torch and leads within a period of one (1) year from its date of delivery to you, with the exception of the HPRXD short torch with integrated lead, which shall be within a period of six (6) months from the date of delivery to you, and with respect to torch lifter assemblies within a period of one (1) year from its date of delivery to you, and with respect to Automation products one (1) year from its date of delivery to you, with the exception of the EDGE Connect CNC, EDGE Connect T CNC, EDGE Connect TC CNC, EDGE Pro CNC, EDGE Pro Ti CNC, MicroEDGE Pro CNC, and ArcGlide THC, which shall be within a period of two (2) years from the date of delivery to you, and (iii) with respect to HyIntensity fiber laser components within a period of two (2) years from the date of its delivery to you, with the exception of laser heads and beam delivery cables, which shall be within a period of one (1) year from its date of delivery to you.

All third-party engines, engine accessories, alternators, and alternator accessories are covered by the respective manufacturers' warranties and not covered by this warranty.

This warranty shall not apply to any Powermax brand power supplies that have been used with phase converters. In addition, Hypertherm does not warranty systems that have been damaged as a result of poor power quality, whether from phase converters or incoming line power. This warranty shall not apply to any product which has been incorrectly installed, modified, or otherwise damaged.

Hypertherm provides repair, replacement or adjustment of the Product as the sole and exclusive remedy, if and only if the warranty set forth herein properly is invoked and applies. Hypertherm, at its sole option, shall repair, replace, or adjust, free of charge, any defective Products covered by this warranty which shall be returned with Hypertherm's prior authorization (which shall not be unreasonably withheld), properly packed, to Hypertherm's place of business in Hanover, New Hampshire, or to an authorized Hypertherm repair facility, all costs, insurance and freight pre paid by the customer. Hypertherm shall not be liable for any repairs, replacement, or adjustments of Products covered by this warranty, except those made pursuant to this paragraph and with Hypertherm's prior written consent.

The warranty set forth above is exclusive and is in lieu of all other warranties, express, implied, statutory, or otherwise with respect to the Products or as to the results which may be obtained therefrom, and all implied warranties or conditions of quality or of merchantability or fitness for a particular purpose or against infringement. The foregoing shall constitute the sole and exclusive remedy for any breach by Hypertherm of its warranty.

Distributors/OEMs may offer different or additional warranties, but Distributors/OEMs are not authorized to give any additional warranty protection to you or make any representation to you purporting to be binding upon Hypertherm.

Patent indemnity

Except only in cases of products not manufactured by Hypertherm or manufactured by a person other than Hypertherm not in strict conformity with Hypertherm's specifications and in cases of designs, processes, formulae, or combinations not developed or purported to be developed by Hypertherm, Hypertherm will have the right to defend or settle, at its own expense, any suit or proceeding brought against you alleging that the use of the Hypertherm product, alone and not in combination with any other product not supplied by Hypertherm, infringes any patent of any third party. You shall notify Hypertherm promptly upon learning of any action or threatened action in connection with any such alleged infringement (and in any event no longer than fourteen (14) days after learning of any action or threat of action), and Hypertherm's obligation to defend shall be conditioned upon Hypertherm's sole control of, and the indemnified party's cooperation and assistance in, the defense of the claim.

Limitation of liability

In no event shall Hypertherm be liable to any person or entity for any incidental, consequential direct, indirect, punitive or exemplary damages (including but not limited to lost profits) regardless of whether such liability is based on breach of contract, tort, strict liability, breach of warranty, failure of essential purpose, or otherwise, and even if advised of the possibility of such damages. Hypertherm shall not be liable for any losses to Distributor based on down time, lost production or lost profits. It is the intention of the Distributor and Hypertherm that this provision be construed by a court as being the broadest limitation of liability consistent with applicable law.

National and local codes

National and local codes governing plumbing and electrical installation shall take precedence over any instructions contained in this manual. In no event shall Hypertherm be liable for injury to persons or property damage by reason of any code violation or poor work practices.

Warranty

Liability cap

In no event shall Hypertherm's liability, if any, whether such liability is based on breach of contract, tort, strict liability, breach of warranties, failure of essential purpose or otherwise, for any claim, action, suit or proceeding (whether in court, arbitration, regulatory proceeding or otherwise) arising out of or relating to the use of the Products exceed in the aggregate the amount paid for the Products that gave rise to such claim.

Insurance

At all times you will have and maintain insurance in such quantities and types, and with coverage sufficient and appropriate to defend and to hold Hypertherm harmless in the event of any cause of action arising from the use of the products.

Transfer of rights

You may transfer any remaining rights you may have hereunder only in connection with the sale of all or substantially all of your assets or capital stock to a successor in interest who agrees to be bound by all of the terms and conditions of this Warranty. Within thirty (30) days before any such transfer occurs, you agree to notify in writing Hypertherm, which reserves the right of approval. Should you fail timely to notify Hypertherm and seek its approval as set forth herein, the Warranty set forth herein shall be null and void and you will have no further recourse against Hypertherm under the Warranty or otherwise.

Waterjet product warranty coverage

Product	Parts coverage
HyPrecision pumps	27 months from the ship date, or 24 months from the date of proven installation, or 4,000 hours, whichever occurs first
PowerDredge abrasive removal system	15 months from the ship date or 12 months from the date of proven installation, whichever occurs first
EcoSift abrasive recycling system	15 months from the ship date or 12 months from the date of proven installation, whichever occurs first
Abrasive metering devices	15 months from the ship date or 12 months from the date of proven installation, whichever occurs first
On/off valve air actuators	15 months from the ship date or 12 months from the date of proven installation, whichever occurs first
Diamond orifices	600 hours of use with the use of a thimble filter and compliance with Hypertherm's water quality requirements

Consumable parts are not covered by this warranty. Consumable parts include, but are not limited to, high-pressure water seals, check valves, cylinders, bleed-down valves, low-pressure seals, high-pressure tubing, low- and high-pressure water filters and abrasive collection bags. All third-party pumps, pump accessories, hoppers, hopper accessories, dryer boxes, dryer box accessories and plumbing accessories are covered by the respective manufacturers' warranties and not covered by this warranty.

Introduction

WARNING



ELECTRIC SHOCK CAN KILL

Disconnect electric power before doing installation or maintenance. You can get a serious electric shock if electric power is not disconnected. Electric shock can seriously injure or kill you.

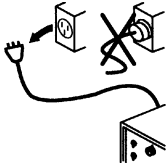

All work that requires removal of the plasma power supply outer cover or panels must be done by a qualified technician.

Refer to the *Safety and Compliance Manual (80669C)* for more safety information.

Purpose

This document gives the steps to connect a compatible* Powermax[®] with an EDGE Connect CNC using the Powermax EtherCAT[®] Interface.

* For a list of compatible Powermax models, refer to **Specifications** at:
hypertherm.com/Powermax-Ethercat-Interface

Necessary tools and materials

- Cables and wires (Refer to [page 12.](#))
- A supported voltage divider assembly (Refer to [page 15.](#))
- AC-DC power supply with a 24 VDC output with a 1 A minimum rating
 - Use a UL/CSA and/or CE certified AC-DC power supply or one that meets local requirements.
 - The 24 VDC output must be isolated from mains and be floating.
- T15 and T20 TORX[®] drivers
- Blade screwdriver

Kit 429010 contents

Part number	Description	Quantity
429014	Powermax EtherCAT Interface	1
	Strain relief bracket for EtherCAT cables	1
	Cable tie for strain relief bracket	1
	Quick-connect terminals for ohmic contact and work lead wires (with heatshrink)	2
	Installation brackets	2
208137	Terminal block: 2-position for 24 V input power	1

Figure 1 – Kit 429010 contents

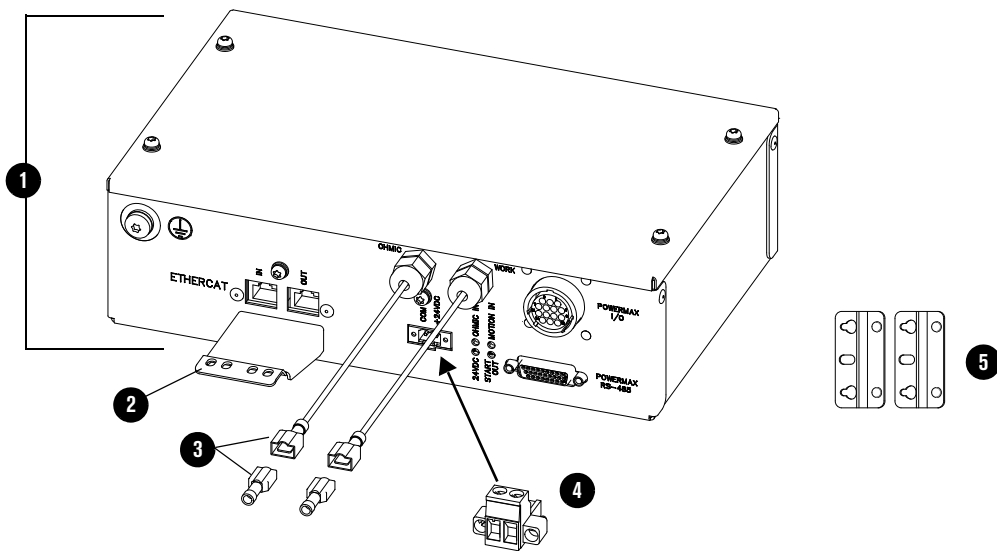

- | | |
|---|--------------------------|
| 1 Powermax EtherCAT Interface | 4 Terminal block** |
| 2 Strain relief bracket for EtherCAT cable* | 5 Installation brackets† |
| 3 Quick-connect terminals for ohmic contact and work lead wires with heatshrink (not shown) | |

* Refer to [Attach the strain relief bracket](#) on page 19.

** It is the customer's responsibility to supply power to the Powermax EtherCAT Interface. Refer to [Necessary tools and materials](#) on page 9.

† Installation brackets can be attached to the rear **or** bottom of the Powermax EtherCAT Interface. Refer to [Installation positions](#) on page 16.

Symbols and marks

Your product may have one or more of the following marks on or near the data plate. Because of differences and conflicts in national regulations, not all marks are applied to every version of a product.



S mark

The S mark indicates that the power supply and torch are suitable for operations carried out in environments with increased hazard of electrical shock according to IEC 60974-1.



CSA mark

Products with a CSA mark meet the United States and Canadian regulations for product safety. The products were evaluated, tested, and certified by CSA-International. Alternatively, the product may have a mark by one of the other Nationally Recognized Testing Laboratories (NRTL) accredited in both the United States and Canada, such as UL or TÜV.



CE mark

The CE marking signifies the manufacturer's declaration of conformity to applicable European directives and standards. Only those versions of products with a CE marking located on or near the data plate comply with European Directives. Applicable directives may include the European Low Voltage Directive, the European Electromagnetic Compatibility (EMC) Directive, the Radio Equipment Directive (RED), and the Restriction of Hazardous Substances (RoHS) Directive. See the European CE Declaration of Conformity for details.



Eurasian Customs Union (CU) mark

CE versions of products that include an EAC mark of conformity meet the product safety and EMC requirements for export to Russia, Belarus, and Kazakhstan.



GOST-TR mark

CE versions of products that include a GOST-TR mark of conformity meet the product safety and EMC requirements for export to the Russian Federation.



RCM mark

CE versions of products with an RCM mark comply with the EMC and safety regulations required for sale in Australia and New Zealand.



CCC mark

The China Compulsory Certification (CCC) mark indicates that the product has been tested and found compliant with product safety regulations required for sale in China.



UkrSEPRO mark

The CE versions of products that include a UkrSEPRO mark of conformity meet the product safety and EMC requirements for export to the Ukraine.



Serbian AAA mark

CE versions of products that include a AAA Serbian mark meet the product safety and EMC requirements for export to Serbia.



RoHS mark

The RoHS mark indicates that the product meets the requirements of the European Restriction of Hazardous Substances (RoHS) Directive.



United Kingdom Conformity Assessed mark

CE versions of products that include a UKCA mark of conformity meet the product safety, EMC, RF, and RoHS requirements for export to the UK.

Cables and wires

All 7 connections shown below are necessary to install the Powermax EtherCAT Interface. These cables and wires are not included in kit 429010.

Figure 2 – System diagram of necessary cables and wires

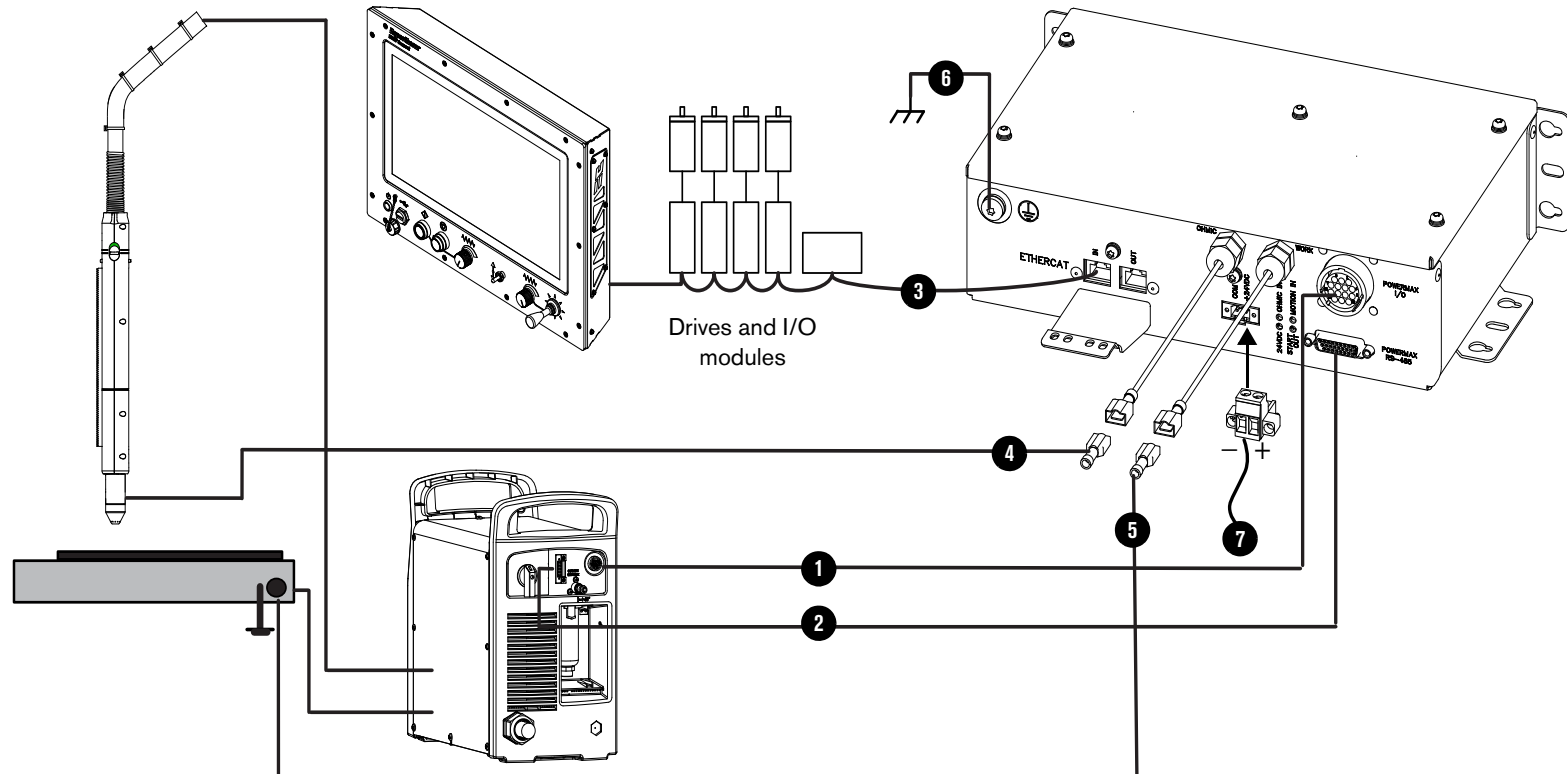

- | | | | |
|---|--|---|--|
| 1 | External machine interface cable | 6 | EMI ground cable from the M6 ground screw |
| 2 | External RS-485 serial interface cable | 7 | 24 VDC power input cable from the green terminal block to the customer-supplied AC-DC power supply |
| 3 | EtherCAT cable | | |
| 4 | Ohmic contact wire to torch tip | | |
| 5 | Work lead connection wire | | |

Cables available from Hypertherm

The cables that follow are necessary to install kit 429010 and are available from Hypertherm.

Figure 3

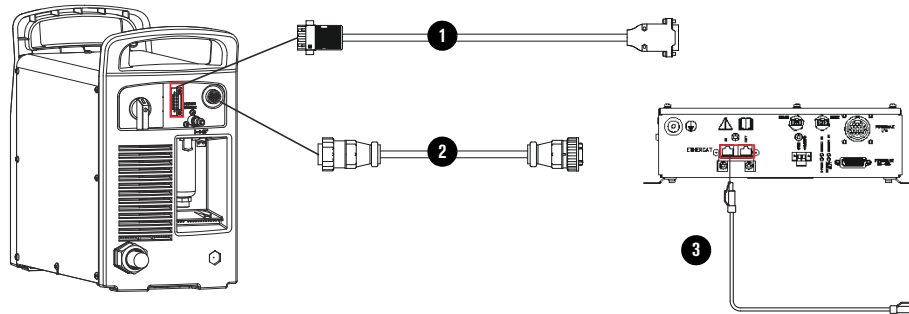

- 1 External RS-485 serial interface cable
- 2 External machine interface cable
- 3 EtherCAT cable
- 4 Ohmic contact wire (not shown)

1 External RS-485 serial interface cables

Part number	Length
223818	0.9 meters (3 feet)
223770	3 meters (10 feet)
223758	7.6 meters (25 feet)
223771	15 meters (50 feet)

2 External machine interface cables

Part number	Length
223817	0.9 meters (3 feet)
223772	3 meters (10 feet)
223759	7.6 meters (25 feet)
223773	15 meters (50 feet)

3 External EtherCAT cables

Part number	Length
223506	0.3 meters (1 feet)
223507	0.6 meters (2 feet)
223508	1.5 meters (5 feet)
223672	2.5 meters (8 feet)
223509	3.0 meters (10 feet)
223510	6.0 meters (19.5 feet)
223511	7.5 meters (24.5 feet)
223512	10 meters (33 feet)
223513	15 meters (49 feet)
223514	22.5 meters (74 feet)
223515	30 meters (98.5 feet)
223516	45 meters (147.5 feet)
223517	60 meters (197 feet)
223714	75 meters (246 feet)



All EtherCAT cables used in the cutting system must follow the guidelines in the *EDGE Connect Installation and Setup Manual* available at www.hypertherm.com/docs. All Hypertherm cables are manufactured to these guidelines and are listed above.

4 Ohmic contact wire

Part number	Length
223766	3 meters (10 feet)
223767	7.6 meters (25 feet)
223768	15 meters (50 feet)
223769	22.5 meters (75 feet)

Additional cables and wires (customer-supplied)

The additional cables that follow are necessary to install kit 429010. These cables are not available from Hypertherm.

- Work lead connection wire (Necessary for ohmic contact continuity. Hypertherm recommends an 18 AWG wire.)

 Connecting wires for the ohmic contact and work lead wires are installed with kit 429010. Heat shrink is included. Refer to [page 24](#).

- EMI ground cable
- 24 VDC power input cable (A 2-position terminal block is supplied.)

Machine interface receptacle with internal cables and voltage divider PCB

The Powermax EtherCAT Interface is only compatible with the latest version of the Powermax voltage divider PCB and machine interface receptacle. If you have an old version, you must remove it and install the latest version.

Look at the machine interface receptacle on the rear of the Powermax plasma power supply. Refer to [Figure 4](#).

- If sockets 1 and 2 are installed, then you have the correct voltage divider PCB and machine interface receptacle for the Powermax EtherCAT Interface.
- **If sockets 1 and 2 are empty, replace the voltage divider PCB and machine interface receptacle using one of the kit numbers below.**
 - Powermax45 XP and Powermax45 SYNC (428653)
 - Powermax65/85 and Powermax65/85 SYNC (228697)
 - Powermax105/125 (228884)
 - Powermax105 SYNC (528045)

Figure 4 – Correct voltage divider receptacle (first image) and incorrect voltage divider receptacle (second image)

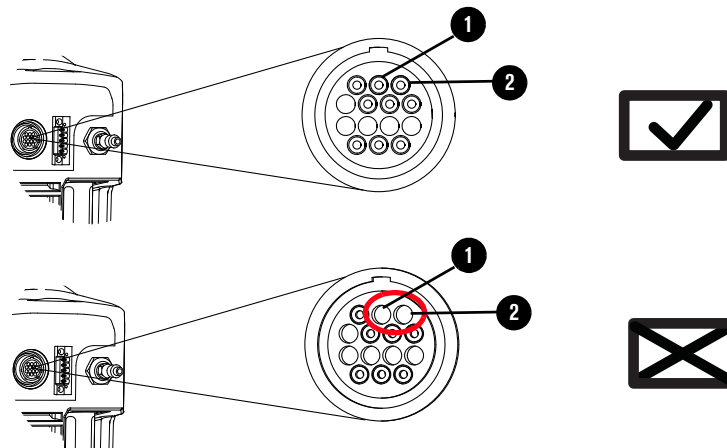

Installation positions and dimensions

You can install the Powermax EtherCAT Interface in a few positions. Select the position that best fits your equipment and space.

Installation positions

To minimize the strain on the cables and wires, **Hypertherm recommends that you install the Powermax EtherCAT Interface in one of the positions shown in [Figure 5](#).**

Figure 5 – Recommended installation positions

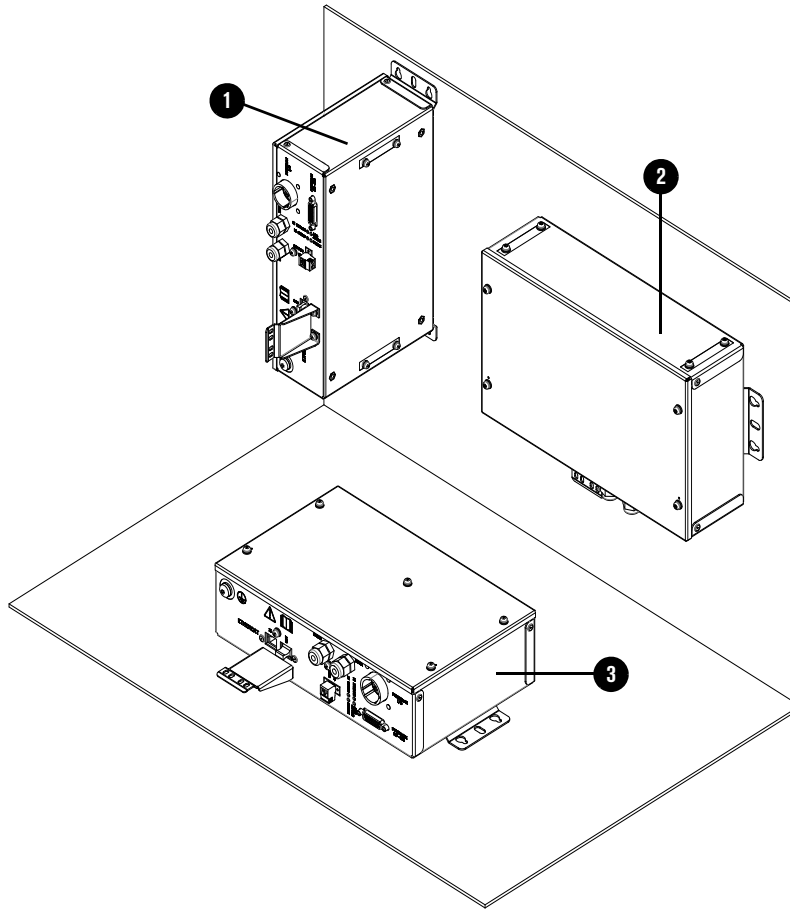

- 1 Vertical surface with cables pointing out
- 2 Vertical surface with cables pointing down
- 3 Horizontal surface with cables pointing out

The dimensions for position 1 (shown in [Figure 5](#)) are different than the dimensions for positions 2 and 3.

Dimensions for position 1*

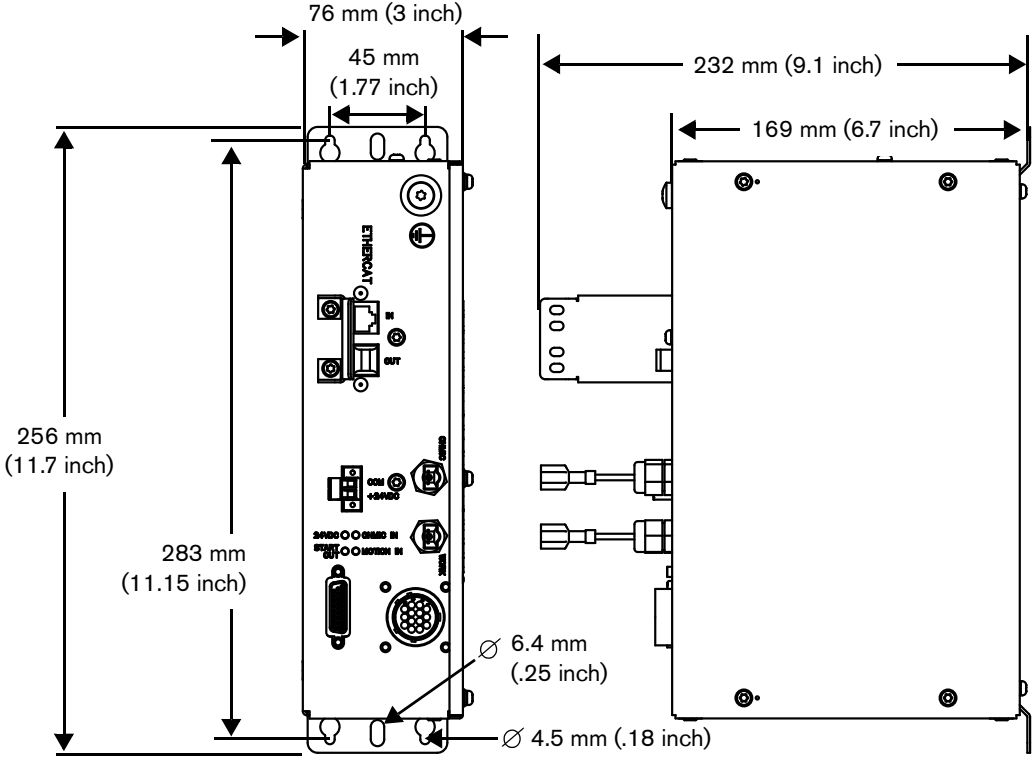

Dimensions for positions 2 and 3*

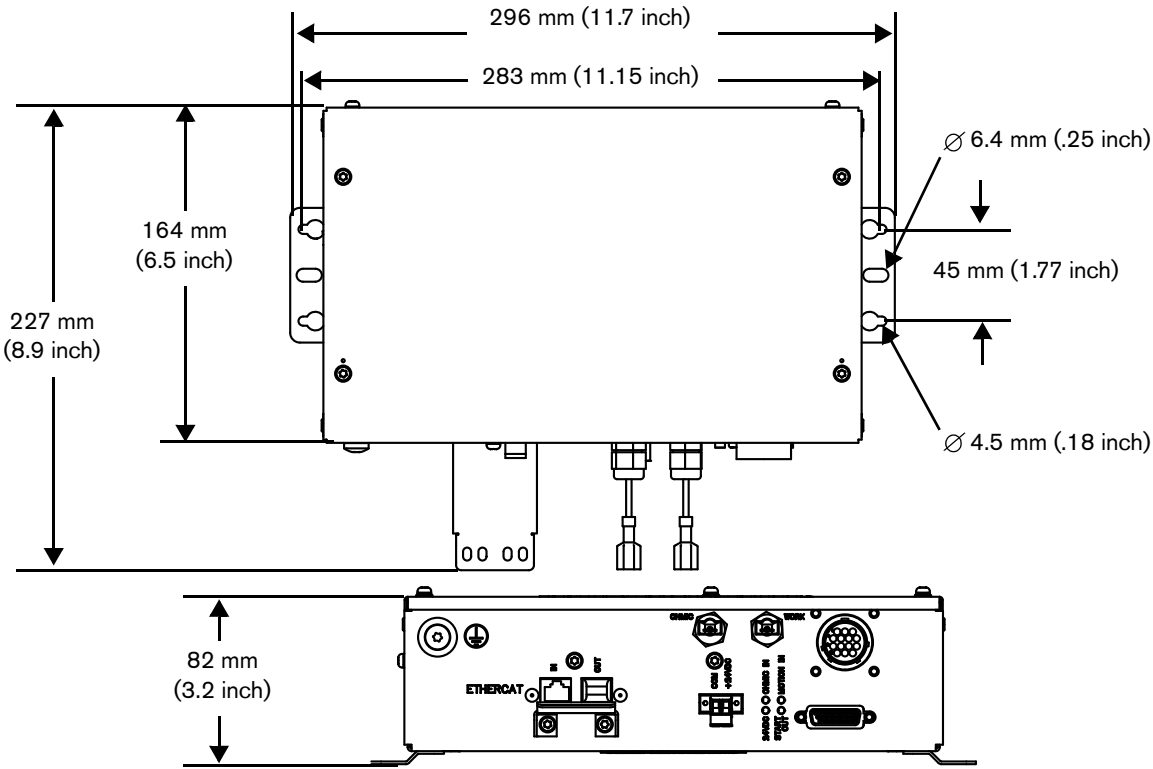

* Positions 1, 2, and 3 are shown on [page 16](#).

Before you begin

Before you install the Powermax EtherCAT Interface, it is important to know these guidelines:

- Each Powermax EtherCAT Interface supports one Powermax plasma power supply. A maximum of four Powermax EtherCAT Interfaces can be installed on the EtherCAT network.
- When installing a Powermax EtherCAT interface with one or more EtherCAT plasma power supplies, make sure the XPR or HPR is before the Powermax EtherCAT interface.

Figure 6 – Physical sequence of an XPR (or HPRXD) and a Powermax on an EtherCAT network

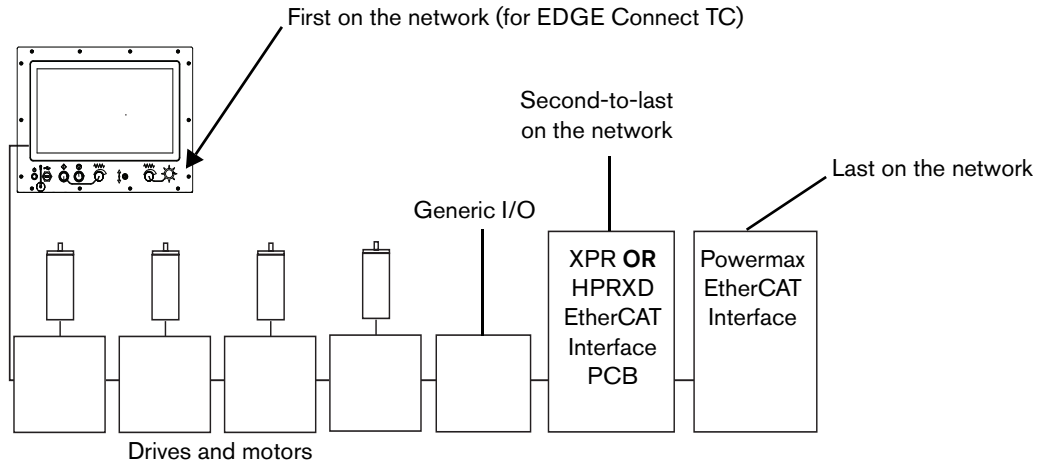

- Do not install XPR and HPR plasma supplies on the same EtherCAT network.
- On the Station Configuration screen in Phoenix, set up the EtherCAT plasma power supplies first, starting with Station 1. Set up tools with discrete connections on remaining stations.



For common Station Configuration examples, refer to *Cut with Powermax on an EDGE Connect CNC* (810290) available at www.hypertherm.com/docs.

- Make sure that the arc voltage ratio on your Powermax plasma power supply is set to the factory default setting of 50:1. Refer to [Figure 7](#).

Figure 7 – The DIP switches on the voltage divider PCB are set to the factory default of 50:1.

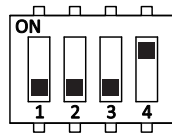

For more information, refer to these Field Service Bulletins:

- *Powermax45 XP Machine Interface Receptacle with Voltage Divider PCB* (809940)
- *Machine Interface Receptacle with Voltage Divider PCB* (806980)

Installation task overview

Do these tasks when you install the Powermax EtherCAT Interface.

- Attach the strain relief bracket for the EtherCAT cable to the Powermax EtherCAT Interface. Refer to the next section.
- Attach the installation brackets to the Powermax EtherCAT Interface. Refer to [page 20](#).
- Attach the Powermax EtherCAT Interface.
- Connect the cables and wires. Refer to [page 21](#).
- Configure the EtherCAT® network. Refer to [page 25](#).
- Monitor the status of inputs and outputs. Refer to [page 26](#).

Attach the strain relief bracket

1. Remove the 2 screws below the EtherCAT ports.

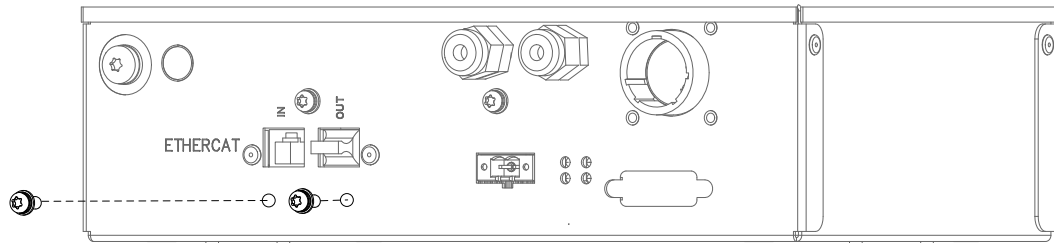

2. Use the 2 screws to install the strain relief bracket.

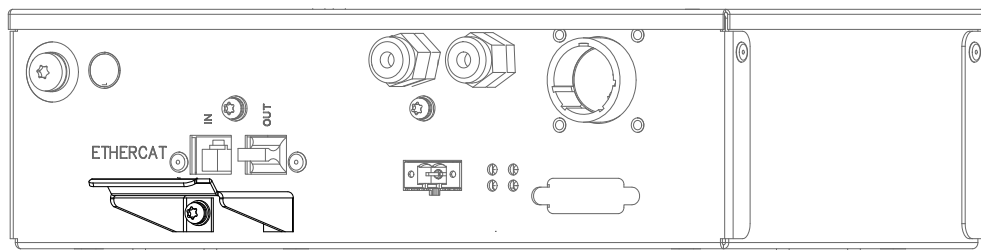

Attach the installation brackets

Attach the brackets to the rear OR to the bottom of the Powermax EtherCAT Interface. Select the installation position that is necessary for your equipment.

Position 1

To install the Powermax EtherCAT Interface in position 1 (on [page 16](#)), do these steps.

1. Remove the 4 screws from the rear of the Powermax EtherCAT Interface.

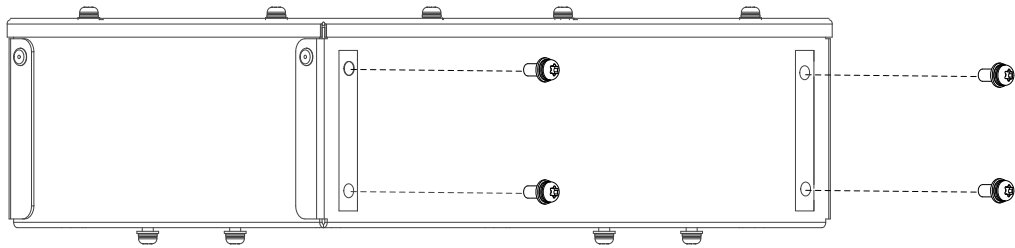

2. Use the 4 screws to attach the brackets to the Powermax EtherCAT Interface.

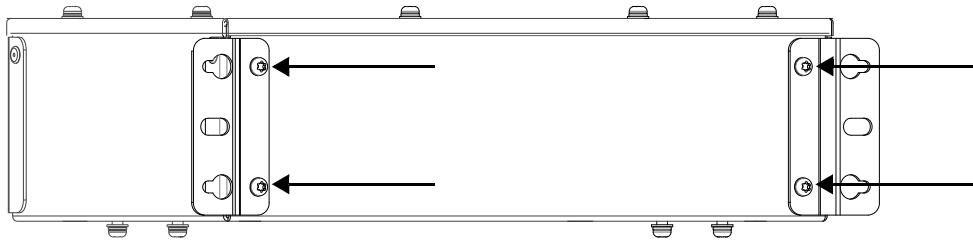

Position 2 and 3

To install the Powermax EtherCAT Interface in position 2 or 3 (on [page 16](#)), do these steps.

1. Remove the 4 screws from the bottom of the Powermax EtherCAT Interface.

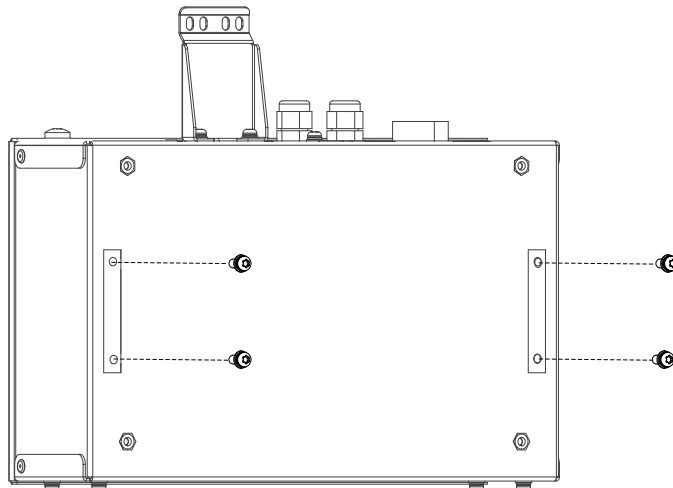

2. Use the 4 screws to attach the brackets to the Powermax EtherCAT Interface.

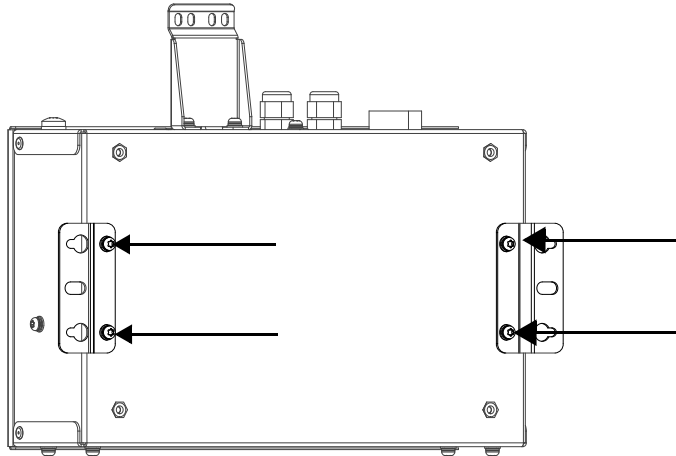

Attach the Powermax EtherCAT Interface

The Powermax EtherCAT Interface is almost the same shape as a drive amplifier, so that you can attach it to a drive cabinet if possible. However, you can attach it to any vertical or horizontal surface if necessary. Screws are not included.

Refer to [Installation positions and dimensions](#) on page 16.

Connect the cables and wires

This section gives a short overview of how to connect the necessary cables and wires.

- EtherCAT cable
- External machine interface cable
- RS-485 serial interface cable
- Ohmic contact and work lead connection wires
- EMI ground cable
- 24 VDC power input

Connect the EtherCAT cable

Figure 8

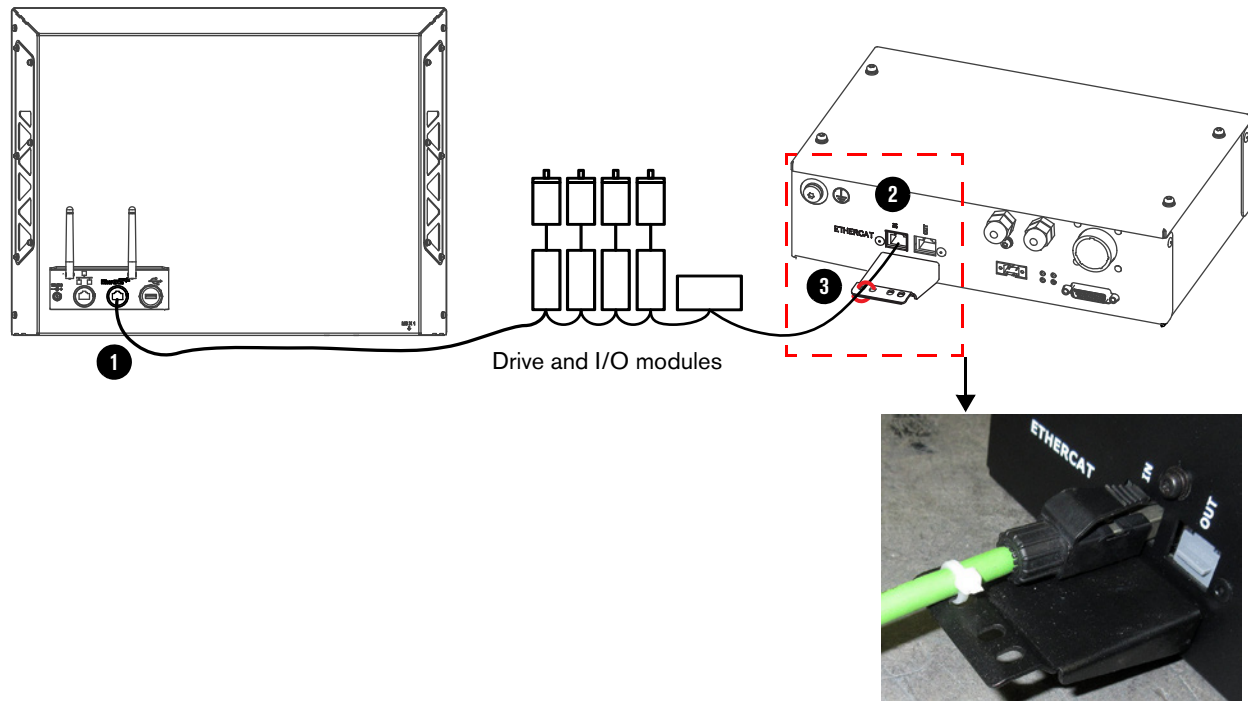

1. Connect one end of the EtherCAT cable to the port marked "IN" ❶ on the Powermax EtherCAT Interface.
2. Connect the other end of the cable to the EtherCAT port ❷ on the rear side of the EDGE Connect CNC.
3. Use a cable tie ❸ to attach the EtherCAT cable to the bracket as a strain relief.



For information about supported EtherCAT cables, refer to [page 14](#).

Connect the Powermax EtherCAT Interface to the Powermax plasma supply

Figure 9

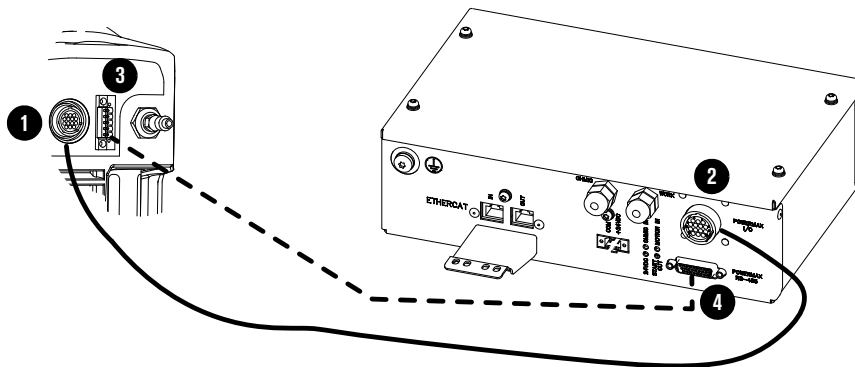

Connect the machine interface cable

1. Connect the machine interface cable to the machine interface receptacle ❶ on the rear of the Powermax plasma power supply. Refer to [Figure 9](#).
2. Connect the other end of the machine interface cable to the machine interface receptacle ❷ on the Powermax EtherCAT Interface.



For information about machine interface cables, refer to [page 13](#).



Connect the RS-485 serial interface cable

1. Connect the RS-485 serial interface cable to the RS-485 receptacle ❸ on the rear of the Powermax plasma power supply. Refer to [Figure 9](#).
2. Connect the 26-pin D-sub connector end of the RS-485 serial interface cable to the serial interface receptacle ❹ on the Powermax EtherCAT Interface.
3. Use a blade screwdriver to attach the connector to the Powermax EtherCAT Interface.



For information about RS-485 serial interface cables, refer to [page 13](#).

Connect the ohmic contact and work lead connection wires

-  The ohmic contact wire is available from Hypertherm. Refer to [Cables and wires](#) on page 12.
-  The work lead connection wire is customer-supplied. Hypertherm recommends an 18 AWG wire.

1. Connect the connector for the ohmic contact wire to the quick-connect receptacle for ohmic contact **1**.

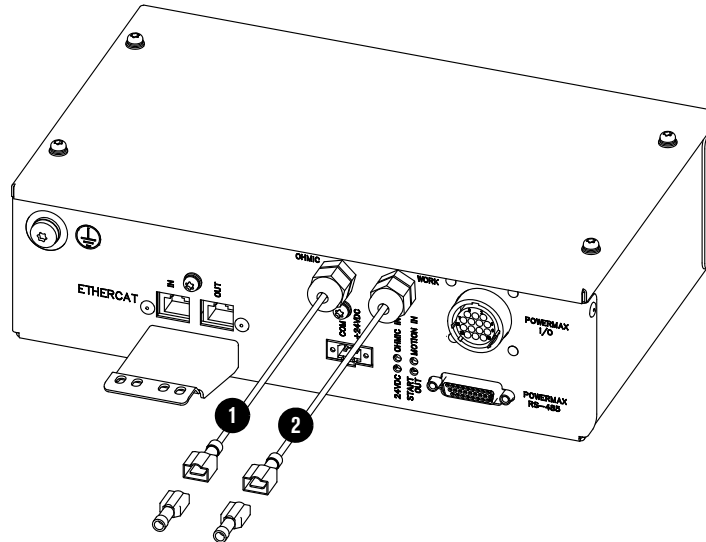

2. Connect the connector for the arc voltage (work) wire to the quick-connect receptacle **2**.

3. Install the heatshrink as follows:

- a. Put the heatshrink on the quick-connects for the ohmic contact and work lead connection wires.
- b. Apply heat. Refer to [Figure 10](#).

4. Make sure that the ohmic contact wire is correctly connected to the torch tip.
5. Make sure that the work lead wire is connected in the correct location. Refer to [Figure 2 – System diagram of necessary cables and wires](#) on page 12.

Figure 10 – The heatshrink is installed.

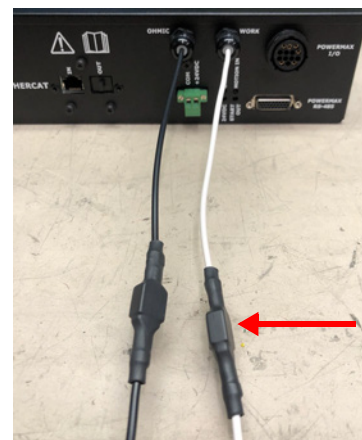

Connect the EMI ground cable

Connect an EMI ground cable to the M6 screw on the Powermax EtherCAT Interface.

Refer to the *EDGE Connect Installation and Setup Manual* (809340) for information about grounding and shielding. Technical documentation is available at www.hypertherm.com/docs.

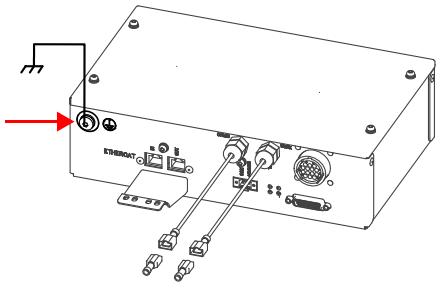

Supply electrical power

Supply AC-DC electrical power with a 24 VDC output to the green terminal block on the Powermax EtherCAT Interface. The terminal block is shown in [Figure 2](#) on page 12.

 Refer to [Necessary tools and materials](#) on page 9 to see more power supply requirements.

Configure the EtherCAT® network

After you install the Powermax EtherCAT Interface, reconfigure the EtherCAT network. Refer to the *EDGE Connect Installation and Setup Manual* (809340) for instructions. Technical documentation is available at www.hypertherm.com/docs.

After you reconfigure the network, make sure that the Powermax shows in the list of connected devices in Hypertherm EtherCAT studio.

Figure 11 – List of connected devices includes Powermax

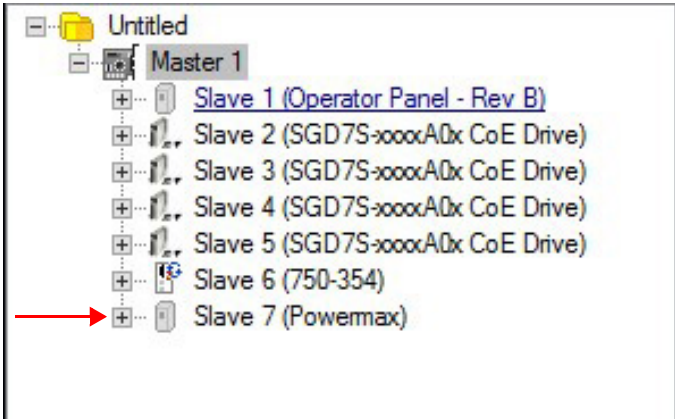

 Phoenix® 10.19.2 or later must be installed on the CNC.

Monitor the status of inputs and outputs

The Powermax EtherCAT Interface includes light-emitting diodes (LEDs) so that you can monitor the status of the inputs and outputs.

Figure 12 – Powermax EtherCAT Interface LEDs

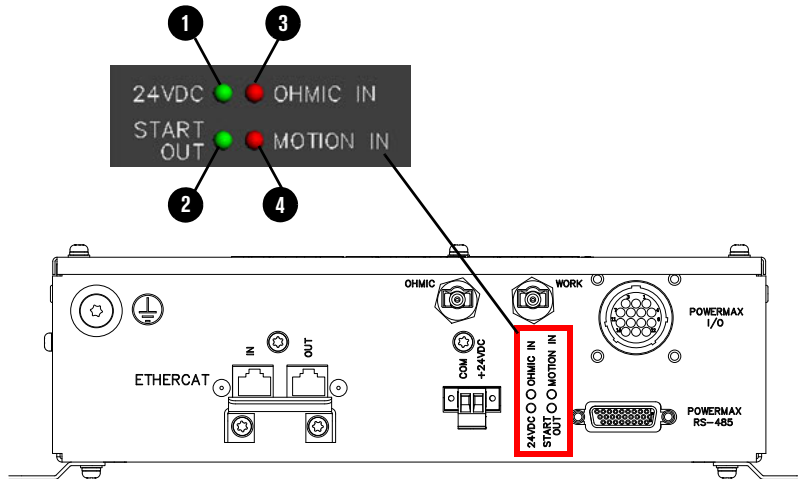

- 1 The 24 VDC green LED comes on when the Powermax EtherCAT Interface is receiving 24 VDC from an external source.
- 2 The green START LED comes on when the CNC sends a Start signal to the plasma power supply.
- 3 The red OHMIC LED comes on when the ohmic contact wire (torch tip) touches the workpiece, such as during initial height sensing or collision sensing.
- 4 The MOTION LED comes on when the arc transfers to the workpiece and motion can begin.